

E1600

E75

TECHNICAL CATALOGUE

SLIDING WINDOW AND DOOR SYSTEM
WITH THERMAL BREAK

E85

E68

ES70

Q72

E75

ES38

E68

EW70

E45

Q60

E8000



ES70

WINDOW AND DOOR SYSTEM WITH THERMAL BREAK

TABLE OF CONTENTS

GENERAL INFORMATION	page 9
BUILDING PHYSICS	page 15
TABLES	page 21
PROFILES	page 25
SECTIONS	page 45
GLAZING OPTIONS	page 71
CUTTING LISTS	page 75
MACHINING	page 95
ACCESSORIES	page 139
CE MARKING	page 175

ETEM HISTORY

ETEM is a leading aluminium extrusion company. It was founded in 1971 as a part of the largest metal manufacturing holding in the Balkans. With over 40 years of experience ETEM is a fully integrated designer and producer of architectural systems and aluminium profiles for industrial applications.

Our mission is to listen and promptly respond to our customers' requests and design and manufacture aluminium products and systems, taking into consideration technical and aesthetic requirements.

ETEM focuses on sustainable development and has proven its concern about the protection of the natural environment by making considerable investments in anti-pollution measures and by optimizing production processes following the applicable standards of the European Union.

SERVICES WE PROVIDE

ETEM supports you with the following:

- ▷ design of conventional and bespoke architectural system solutions
- ▷ innovative engineering in the field of curtain walls, ventilated facades, doors, windows
- ▷ professional consultation and adequate technical advices ensured by our engineering team with wide experience in the field of profile extrusion as well as architectural systems' engineering

- ▷ reliable customer care constant support trainings, technical support and audits on site
- ▷ high quality engineering which guarantees offering the best solution according to the specific features of every single project
- ▷ managing the process of certification in accordance with the applicable European standards in Notified Bodies
- ▷ production of non-standard length profiles and non-standard processing high quality powder coating

ETEM PRODUCTS AND SUSTAINABLE DEVELOPMENT

SUSTAINABLE DEVELOPMENT IS DEVELOPMENT THAT MEETS THE NEEDS OF THE PRESENT WITHOUT COMPROMISING THE ABILITY OF FUTURE GENERATIONS TO MEET THEIR OWN NEEDS.*

For many, sustainable development is about environmental conservation. This is true but it also includes two other aspects: a social aspect and an economic aspect.

Sustainable development means striking the right balance between economic development, social equity and environmental protection.

For us meeting this objective translates into the challenge of satisfying market demands at the lowest economic, social and environmental cost possible.

ETEM has always designed architectural systems which are in compliance with all requirements for achieving high energy efficiency.

In order to assure the comfort of the building inhabitants, ETEM systems adapt their functions to the changing environment.

As a moderator between outside and inside our systems provide:

- > ENERGY EFFICIENCY
- > DAYLIGHT
- > SUN-SHADING
- > VENTILATION AND GOOD AIR QUALITY
- > SAFETY AND SECURITY

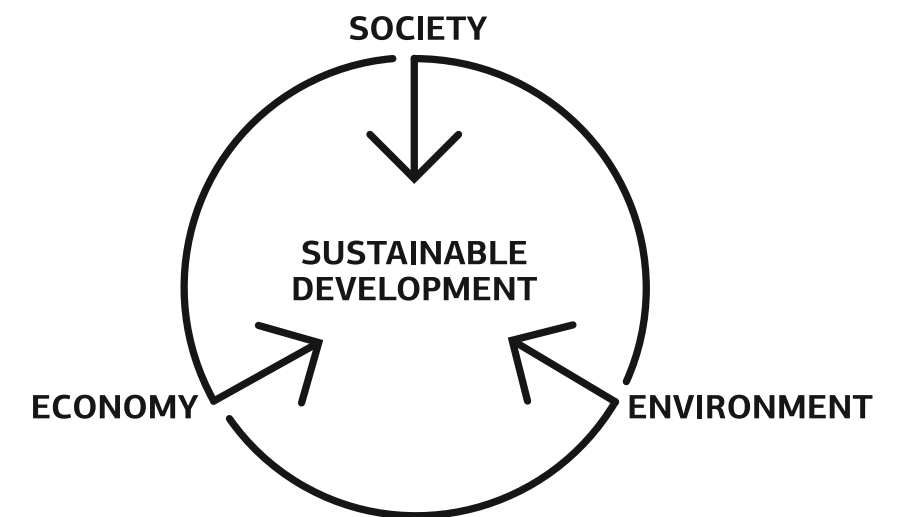

* Extract from Brundtland Report, from the United Nations World Commission on Environment and Development WCED

GENERAL INFORMATION

CONCEPT / ADVANTAGES / CERTIFICATES

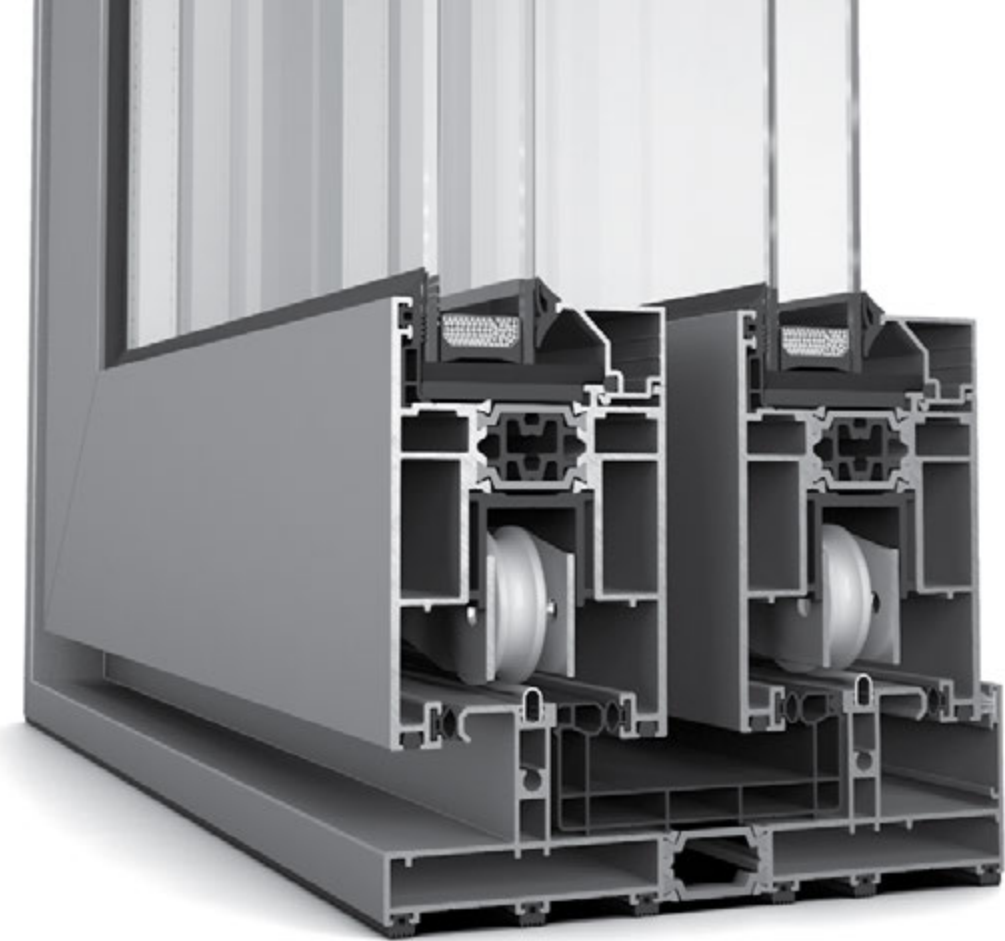

ES70 WINDOW CONCEPT

ES70 IS A HIGH-END SLIDING WINDOW SYSTEM WITH THERMAL BREAK, SUITABLE FOR OPPOSED BALCONY DOORS AND WINDOWS WITH HIGH REQUIREMENTS FOR THERMAL INSULATION, FUNCTIONALITY AND AESTHETICS.

- Elegant straight design
- Excellent water-tightness and air-permeability
- High thermal insulation
- Glazing sash with 70.0mm width allowing glass panel from 25.0 up to 52.0mm
- Ability of Slim Line Interlock
- Maximum weight per sash 400 kg.

COMPLIANCE WITH APPLICABLE REGULATIONS

Production management

Quality Management system is certified in accordance with EN ISO 9001:2008.

Environmental management system is certified in accordance with EN ISO 14001.

Factory production control system is certified according to the requirements of EN 15088. All ETEM profiles are CE marked and in compliance with applicable European Standards.

ETEM is authorized to use the QUALICOAT quality sign for paint, lacquer and powder coating on aluminium for architectural applications.

Occupational Health & Safety Management System is certified in accordance with OHSAS 18001.

PERFORMANCE CHARACTERISTICS OF ES70

Characteristic	Classification / value	Standard
Air permeability	Up to class 4	EN 1026 / EN 12207
Watertightness	Up to class E900	EN 1027 / EN 12208
Resistance to wind load	Up to class C5	EN 12211 / EN 12210
Thermal transmittance	from 2,73 W/m ² .K	EN ISO 10077-2

CLASSIFICATION OF CHARACTERISTICS

for windows without resistance to fire and/or smoke leakage characteristics according to EN 14351-1

Characteristic / value / dimension	Classification / Value										
Resistance to wind load	npd	1	2	3	4	5	Exxxx				
Test pressure P1 (Pa)		(400)	(800)	(1200)	(1600)	(2000)	(>2000)				
Resistance to wind load	npd	A		B		C					
Frame deflection		(≤1/150)		(≤1/200)		(≤1/300)					
Resistance to snow and permanent load	npd	Declared information on the infill (e.g. type and thickness of glass)									
Reaction to fire	npd	F	E	D	C	B	A2	A1			
External fire performance	npd	According to EN 13501-5									
Watertightness		1A	2A	3A	4A	5A	6A	7A	8A	9A	Exxxx
Non-shielded (A)		(0)	(50)	(100)	(150)	(200)	(250)	(300)	(450)	(600)	(>600)
Test pressure (Pa)											
Watertightness		1B	2B	3B	4B	5B	6B	7B			
Shielded (B)	npd	(0)	(50)	(100)	(150)	(200)	(250)	(300)			
Test pressure (Pa)											
Dangerous substances	npd	As required by regulations									
Impact resistance	npd	200	300	450	700	950					
Drop height (mm)											
Load-bearing capacity of safety devices	npd ^a	Threshold value									
Acoustic performance		Declared values									
Sound insulation	npd										
R _w (C;C _{tr}) (dB)											
Thermal transmittance	npd	Declared values									
U _w (W/(m ² .K))											
Radiation properties	npd	Declared values									
Solar factor (g)											
Radiation properties	npd	Declared values									
Light transmittance (τ _v)											
Air permeability		1	2	3	4						
Max. test pressure (Pa)		(150)	(300)	(600)	(600)						
Reference air permeability at 100 Pa	npd	(50 or 12.50)	(27 or 6.75)	(9 or 2.25)	(3 or 0.75)						
(m ³ /(h · m ²) or m ³ /(h · m))											
Operating forces^b	npd	1	2								
Mechanical strength	npd	1	2	3	4						
Ventilation		Declared values									
Air flow exponent n	npd										
Air flow characteristic K											
Air flow rates											
Bullet resistance	npd	FB1	FB2	FB3	FB4	FB5	FB6	FB7	FSG		
Explosion resistance	npd	EPR1		EPR2		EPR3		EPR4			
Shock tube											
Explosion resistance	npd	EXR1		EXR2		EXR3		EXR4		EXR5	
Range test											
Resistance to repeated opening and closing	npd	5000			10 000			20 000			
Number of cycles											
Behaviour between different climates	npd	Under development									
Burglar resistance	npd	1	2	3	4	5	6				

NOTE 1: npd: no performance determined

NOTE 2: The figures in brackets are for information

BUILDING PHYSICS

DIMENSIONING / FORMULAS / EXAMPLES

ALUMINIUM AS MATERIAL

ALUMINIUM IS A VERY YOUNG METAL, EXTRACTED FOR THE FIRST TIME IN 1854. COMMERCIALY PRODUCED AS A PRECIOUS METAL FROM 1886, ITS INDUSTRIAL PRODUCTION FOR CIVIL APPLICATIONS ONLY ACHIEVED WIDE USE IN THE 1950'S.

NOW ALUMINIUM PLAYS A KEY ROLE FOR THE SUSTAINABILITY OF NEW BUILDINGS AND THE RENOVATION OF EXISTING ONES. THANKS TO ITS PERFORMANCE PROPERTIES ALUMINIUM CONTRIBUTES TO THE ENERGY PERFORMANCE, SAFETY AND COMFORT OF NEW BUILDINGS.

ADVANTAGES

DESIGN FLEXIBILITY

The extrusion process offers an almost infinite range of forms and sections, allowing designers to integrate numerous functions into one profile

LONG SERVICE LIFE

Aluminium building products are made from alloys that are weatherproof, corrosion-resistant and immune to the harmful effects of UV rays, ensuring optimal performance over a very long period of time

HIGH STRENGTH-TO-WEIGHT RATIO

Thanks to the metal's inherent strength and stiffness, aluminium window and curtain wall frames can be very narrow. Material's light weight makes it easier to transport and handle on-site, reducing the risk of work-related injury

HIGH-REFLECTIVITY

This characteristic feature makes aluminium a very efficient material for light management. Aluminium shading devices can be used to reduce the need for air conditioning in summer

FIRE SAFETY

Aluminium does not burn and therefore is classified as a non-combustible construction material (European Fire Class A1). Aluminium alloys will nevertheless melt at around 6500 C, but without releasing harmful gases

NO RELEASE OF DANGEROUS SUBSTANCES

Several studies have proved that aluminium building products do not present a hazard to occupants or the surrounding environment. Aluminium building products have no negative impact, either on indoor air quality or on soil, surface and groundwater

OPTIMAL SECURITY

Where high security is required, specially designed, strengthened aluminium frames can be used. While the glass for such applications may well be heavy, the overall weight of the structure remains manageable thanks to the light weight of the aluminium frames.

ALLOYS

Aluminium in its pure form is a very soft metal. Thanks to the addition of alloying elements such as copper, manganese, magnesium, zinc, etc. and thanks to suitable production processes, the physical and mechanical properties can be varied in a wide range to satisfy the requirements of a large number of different applications.

ETEM profiles are extruded from the following alloys:

EN AW-1050 [Al 99.5]
EN AW-6060 [Al Mg Si]
EN AW-6063 [Al Mg_{0,7} Si]
EN AW-6061 [Al Mg₁ Si Cu]
EN AW-6005 [Al Si Mg]
EN AW-6082 [Al Si₁ Mg Mn]

The most common aluminium alloy which is used by ETEM is EN AW 6063. Here are the properties of this alloy:

MATERIAL PROPERTIES	
Aluminium alloy	EN F22
Ultimate tensile strength	R _m = 210 N/mm ²
Yield strength	R _{p0.2} = 160 N/mm ²
Modulus of elasticity	E _{al} = 70 000 N/mm ² = 7.10 ⁹ kg/m ²
Coefficient of thermal expansion	α = 0.023 mm/m .K (up to 1.2 mm/m for difference up to 50°C)

EXTRUSION PROCESS

ETEM profiles are obtained through extrusion process, which consists of pushing a hot cylindrical bullet of aluminium through a shaped die. The extrusion process offers almost infinite range of forms and sections, allowing our designers to integrate numerous functions into one single profile.

aluminium surface, increasing hardness, corrosion and abrasion resistance. Anodizing gives a very decorative silver matt surface finish, and colored can also be obtained by sealing metallic dyes into the anodized layer.

MAINTENANCE

Apart from routine cleaning for aesthetic reasons, ETEM aluminium profiles do not require any maintenance which translates into a major cost and ecological advantage over lifetime of the product.

FINISHING

POWDER COATING

It is a type of paint that is applied as a dry powder. Coating is applied on ETEM profiles electrostatically and then is cured under heat to allow it to flow and form a "skin". ETEM is authorized to use the quality sign QUALICOAT for powder coatings on aluminium for architectural applications. A wide range of colors and gloss levels can be achieved. ETEM also offers timber imitations painting, in addition to all RAL colors. The technology EZY provides the following colors: Golden Oak, Acero, Betulla, Mogano, Verde Scuro, Wenge, Noce Fiammato, Noce Chiaro, Ciliegio Rosso, Acacia Scuro, Ciliegio Antico, Noce Reale, Ciliegio Reale.

ANODIZING

It is an electrochemical process whereby to reinforce the natural oxide film on the

CALCULATION OF GLASS PANE THICKNESS

*Glazing thickness:

For single glazing the minimum thickness is given by the following equations:

$$a) \text{ If } \frac{h_g}{l_g} \leq 3, \quad t = \sqrt{\frac{10 \cdot l_g \cdot h_g \cdot w}{72}}, \text{ mm}$$

or

$$b) \text{ If } \frac{h_g}{l_g} > 3, \quad t = \frac{l_g \cdot \sqrt{10 \cdot w}}{72}, \text{ mm}$$

Where:

t - Minimum theoretical glass thickness, mm

w - Wind pressure, kg/m²

l_g - The smallest dimension of the glass pane, m

h_g - The largest dimension of the glass pane, m

For double glazing, the total thickness of both glasses in the panel is equal to the thickness of a single glass pane (evaluated using the above equations) multiplied by 1.5

For triple glazing, the total thickness of all glasses in the panel is equal to the thickness of a single glass pane (evaluated using the above equations) multiplied by 1.7

Always consult facade engineer or glazing manufacturer when calculating for required glazing thickness and maximum allowable dimensions.

Example:

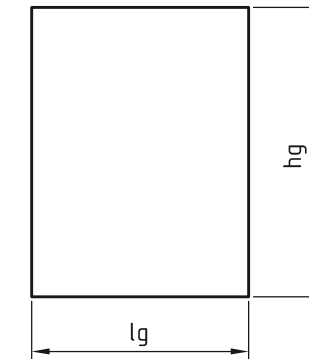

Initial data:

l_g = 1,5 m

h_g = 2,0 m

w = 60 kg/m²

$$\frac{h_g}{l_g} = \frac{2}{1,5} = 1,33 \leq 3$$

$$t = \sqrt{\frac{10 \cdot l_g \cdot h_g \cdot w}{72}} = \sqrt{\frac{10 \cdot 1,5 \cdot 2 \cdot 60}{72}} = \sqrt{\frac{1800}{72}} = 5 \text{ mm}$$

For double glazing t_{req} = 1,5 · 5 = 7,5 mm

We choose double glazing 5/14/5

TABLES

TYPES / LIST OF PROFILES / CHARACTERISTICS

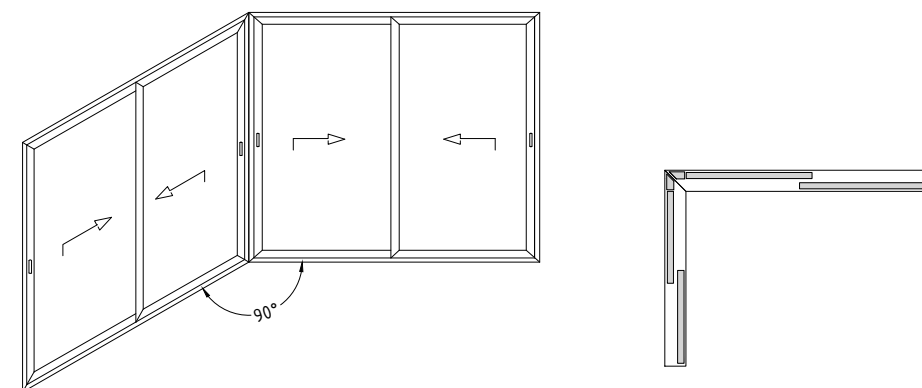
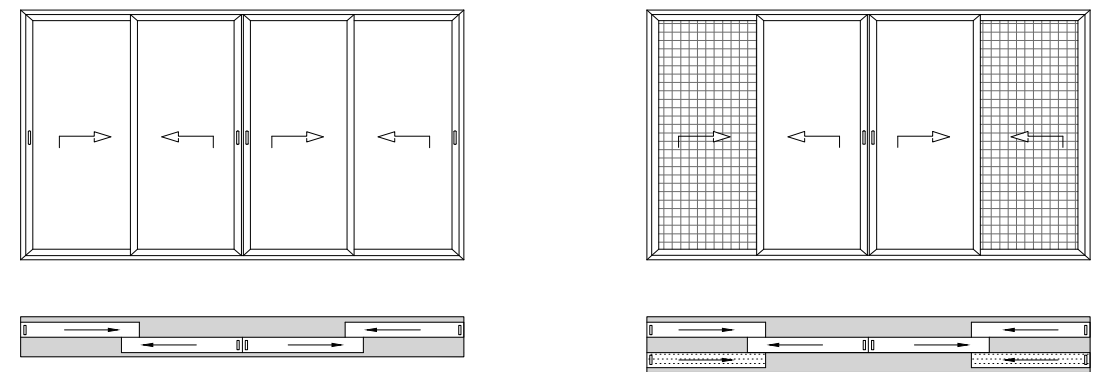
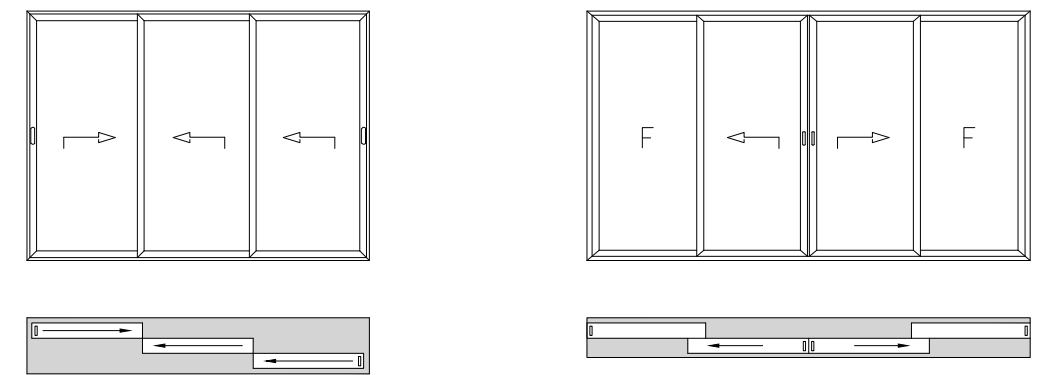
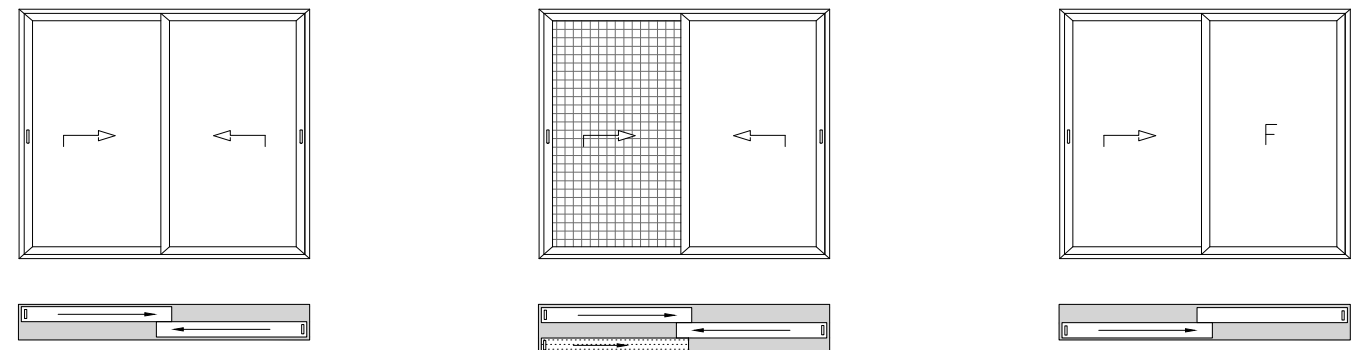

PROFILES

DRAWINGS / SCALE 1:1

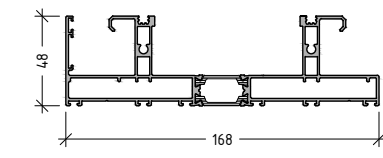
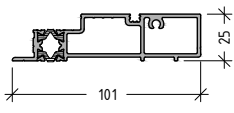
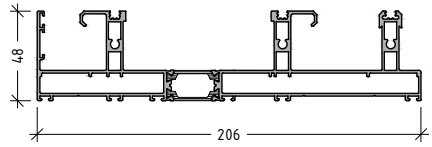
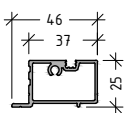
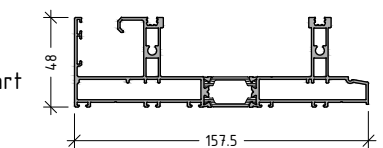
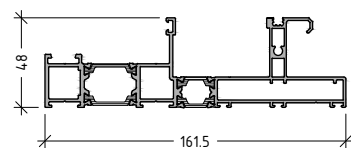
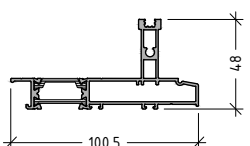
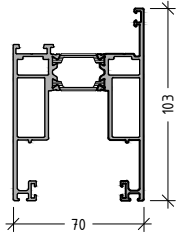
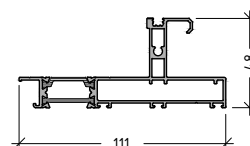
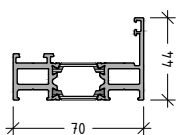
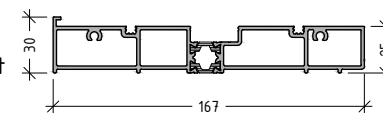
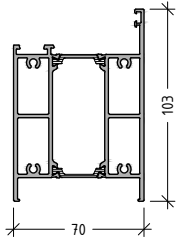
code	profile	weight length moment of inertia	code	profile	weight length moment of inertia
E6270103 Double rail		2711 g/m L=6.01 m	E6270131 Additional flat rail		1510 g/m L=6.01 m
E6270104 Triple rail		3356 g/m L=6.01 m	E6270132 Additional flat rail for fly screen		616 g/m L=6.01 m
E6270105 Internal part of triple - multi rail		2549 g/m L=6.01 m	E6270150 Hotel type rail		2731 g/m L=6.01 m
E6270106 Additional for multi rail		1377 g/m L=6.01 m	E6270201 Glazing sash		2676 g/m L=6.01 m Jx=63.7 cm ⁴ Jy=69.4 cm ⁴
E6270107 Additional part for triple - multi rail		1553 g/m L=6.01 m	E6270250 Narrow sash interlock		1540 g/m L=6.01 m Jx=4.5 cm ⁴ Jy=33.0 cm ⁴
E6270130 Double flat rail		2574 g/m L=6.01 m	E6270350 Hotel type mullion		3087 g/m L=6.01 m Jx=69.0 cm ⁴ Jy=71.1 cm ⁴

sliding system with thermal break

ES70

code	profile	weight length moment of inertia	code	profile	weight length moment of inertia
E6270520 Adjoining corner profile for 90°		2511 g/m L=6.01 m Jx=31.3 cm ⁴ Jy=98.5 cm ⁴	E6270681 Glazing bead		284 g/m L=6.01 m
E6270510 Adjoining profile		1255 g/m L=6.01 m Jx=20.9 cm ⁴ Jy=2.0 cm ⁴	E6270682 Glazing bead		300 g/m L=6.01 m
E6270501 Interlock profile		456 g/m L=6.01 m	E6270683 Glazing bead		340 g/m L=6.01 m
E6270650 Hotel type cap		535 g/m L=6.01 m	E6270684 Glazing bead		328 g/m L=6.01 m
E6270620 Drip profile		410 g/m L=6.01 m	E6270690 Connector for slide-fixed		2016 g/m L=6.01 m Jx=7.5 cm ⁴ Jy=206.5 cm ⁴
E6270680 Glazing bead		215 g/m L=6.01 m	E6270695 Length connector for E50 & ES70		224 g/m L=6.01 m

ES70L-02

sliding system with thermal break

ES70

code	profile	weight length moment of inertia	code	profile	weight length moment of inertia
E6270902 Connecting rod		389 g/m L=6.01 m	E22214 Fly-screen sash		857 g/m L=6.01 m
E6270904 Connecting rod (for narrow sash)		186 g/m L=6.01 m	E22215 "T" profile for fly screen		591 g/m L=6.01 m
E22216 Vertical screen sash		732 g/m L=6.01 m	E19651 Cover for fly screen		100 g/m L=6.01 m
E22616 Cover for fly screen E22216		105 g/m L=6.01 m	E6270220 Screen sash for flat rails E50 & ES70		1112 g/m L=6.01 m
E50901W1 Aluminium drainage grill (available <u>only</u> perforated)		124 g/m L=6.01 m			

ES70L-03

sliding system with thermal break

ES70

E6270103

Double rail

2711 g/m

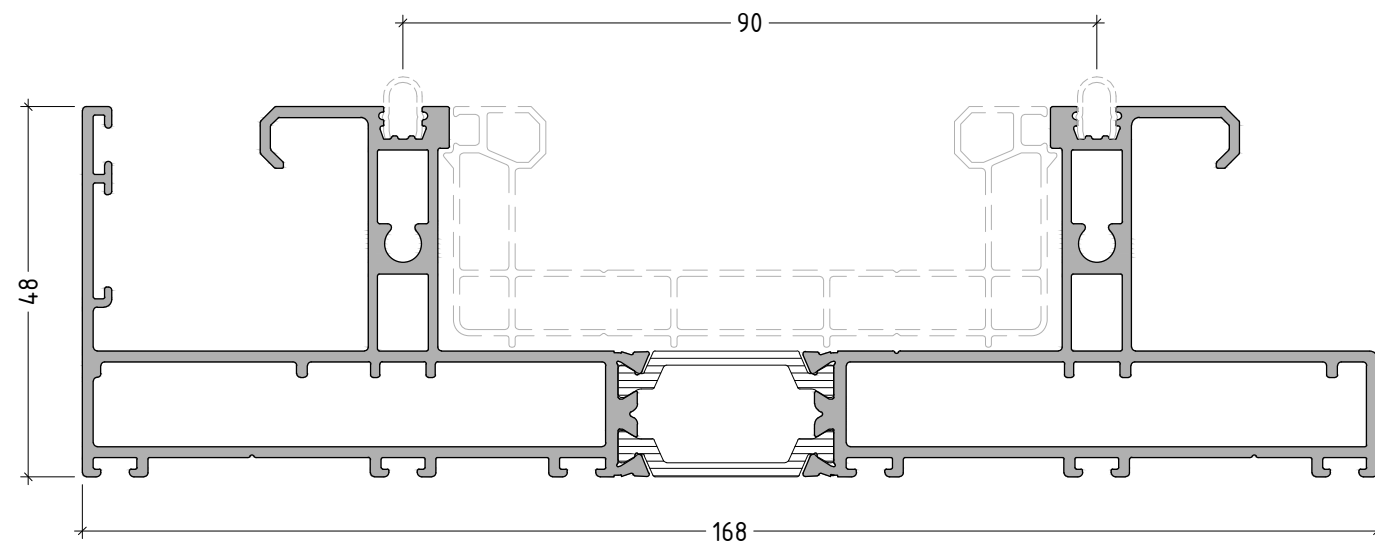

scale : 1:1

ES70.P-01

sliding system with thermal break

ES70

E6270104

Triple rail

3356 g/m

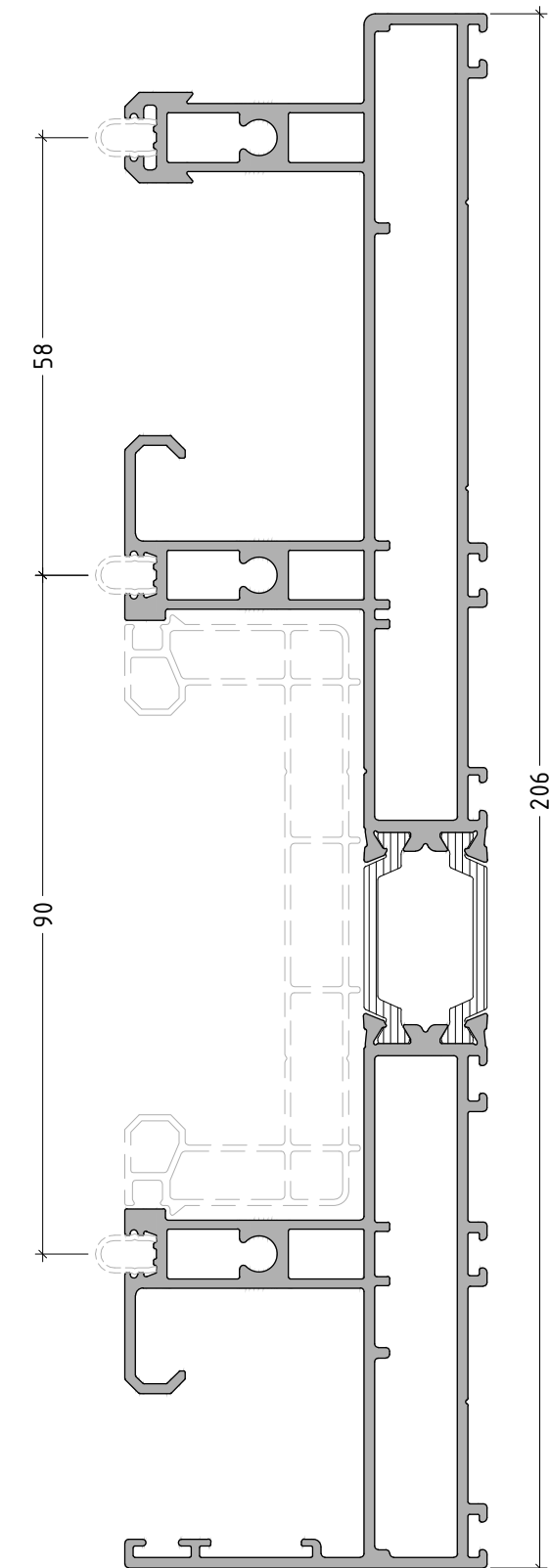

scale : 1:1

ES70.P-02

E6270105

Internal part of triple
- multi rail

2549 g/m

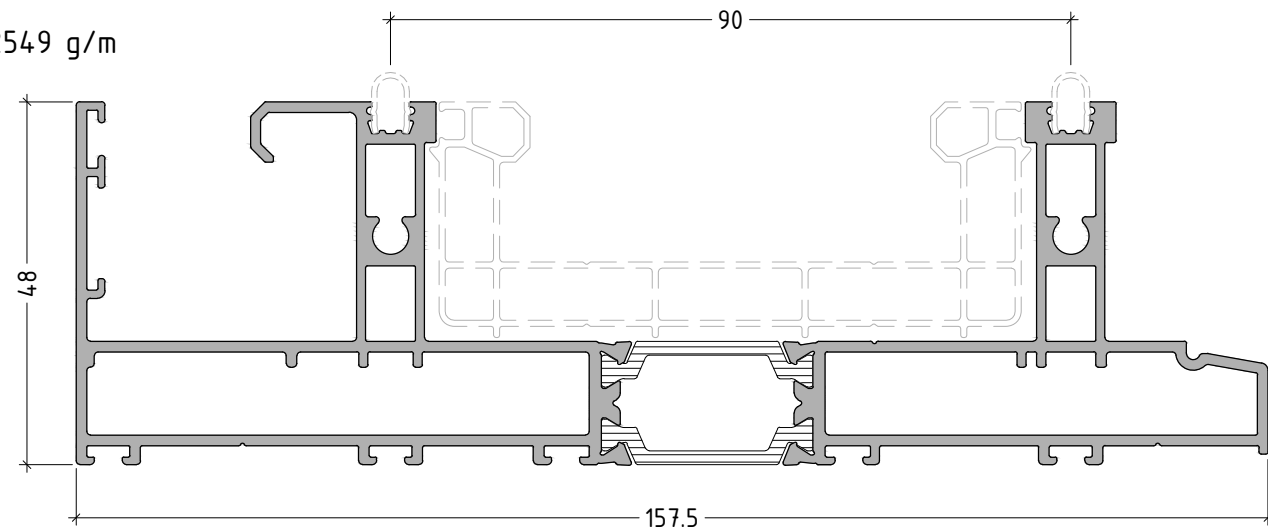

E6270106

Additional rail for
multiple frames

1377 g/m

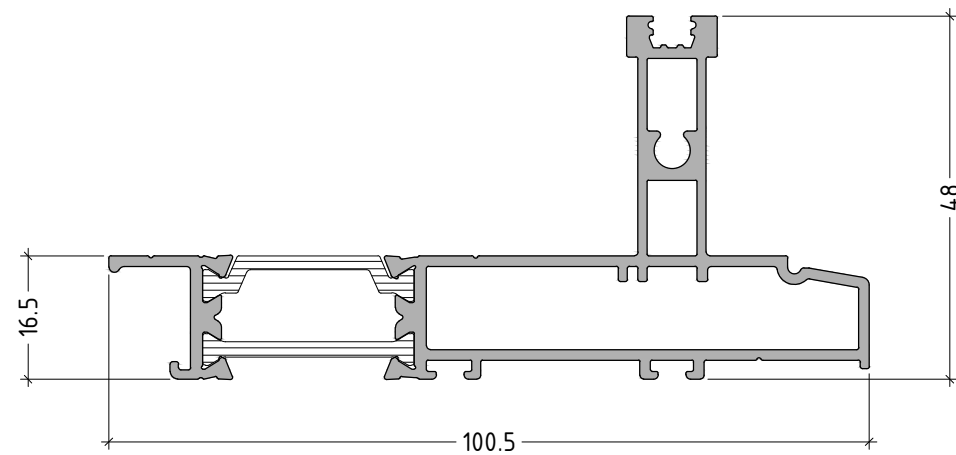

scale : 1:1

ES70.P-03

E6270107

Additional part for
triple - multi rail

1553 g/m

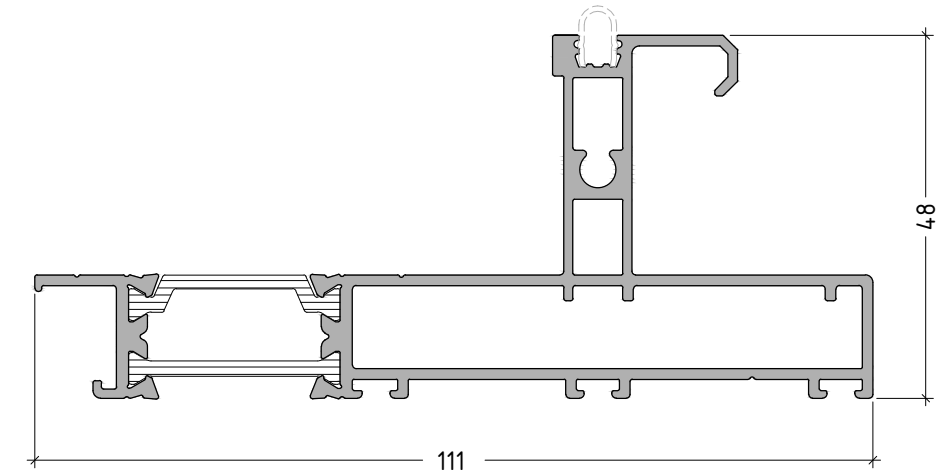

E6270130

Double flat rail

2574 g/m

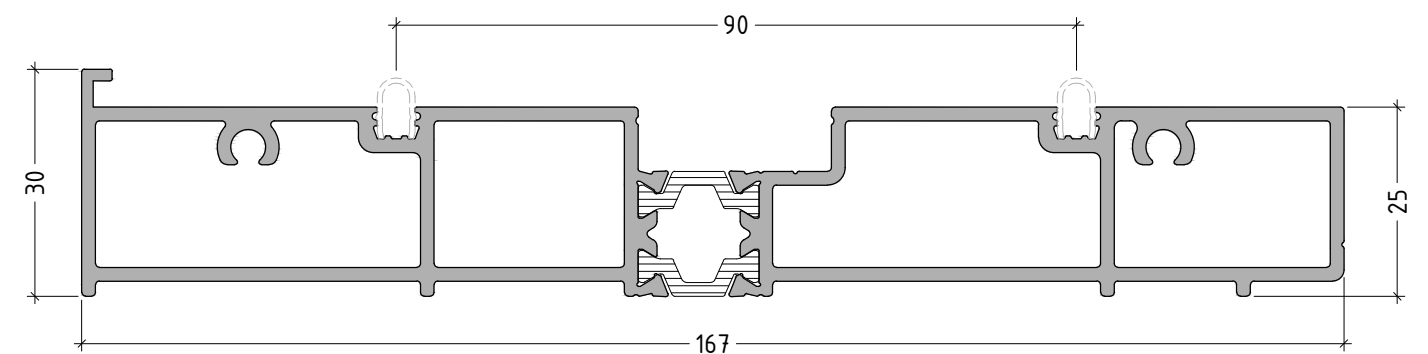

scale : 1:1

ES70.P-04

E6270131

Additional flat rail

1510 g/m

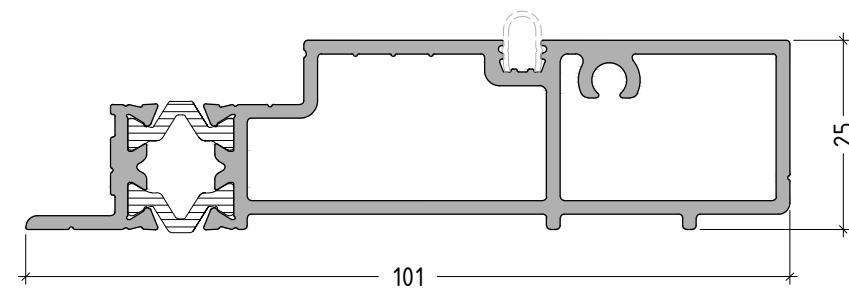

E6270132

Additional flat rail
for fly screen

616 g/m

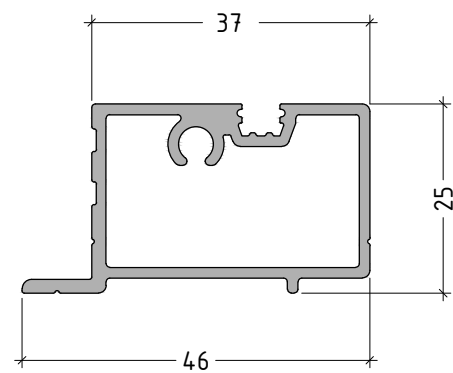

scale : 1:1

ES70.P-05

E6270201

Glazing sash

2676 g/m

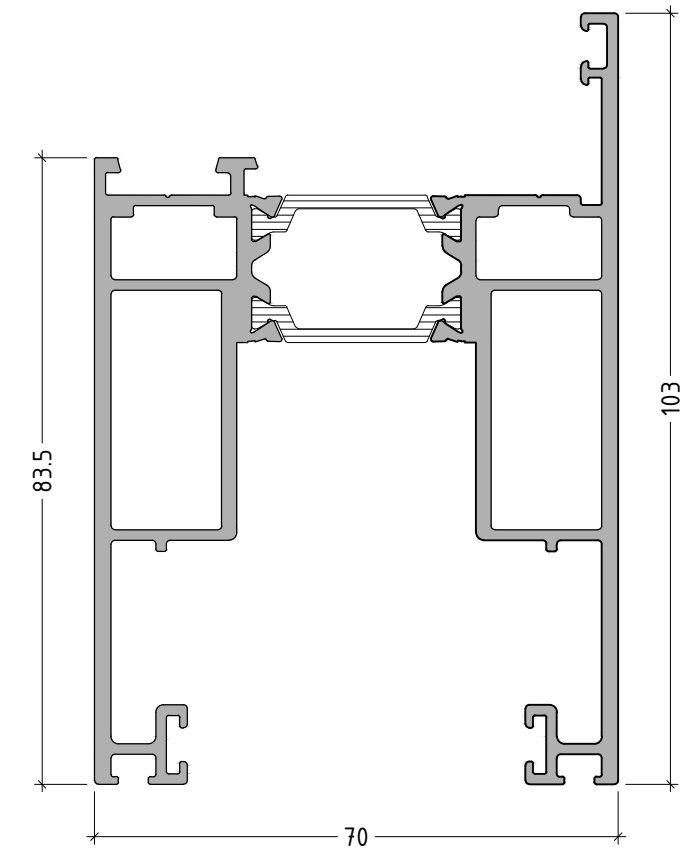

E6270250

Narrow sash interlock

1540 g/m

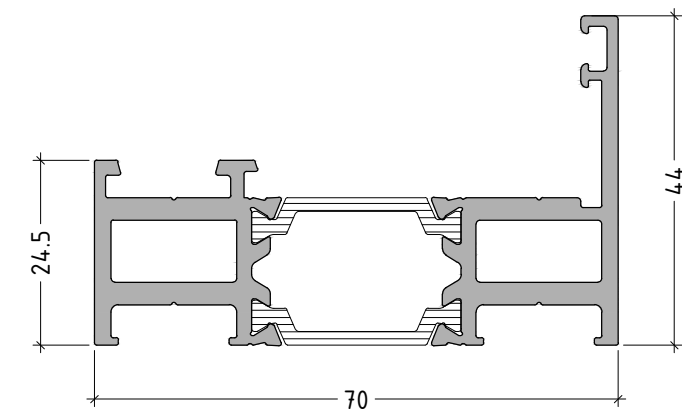

scale : 1:1

ES70.P-06

E6270350
Hotel type mullion
3087 g/m

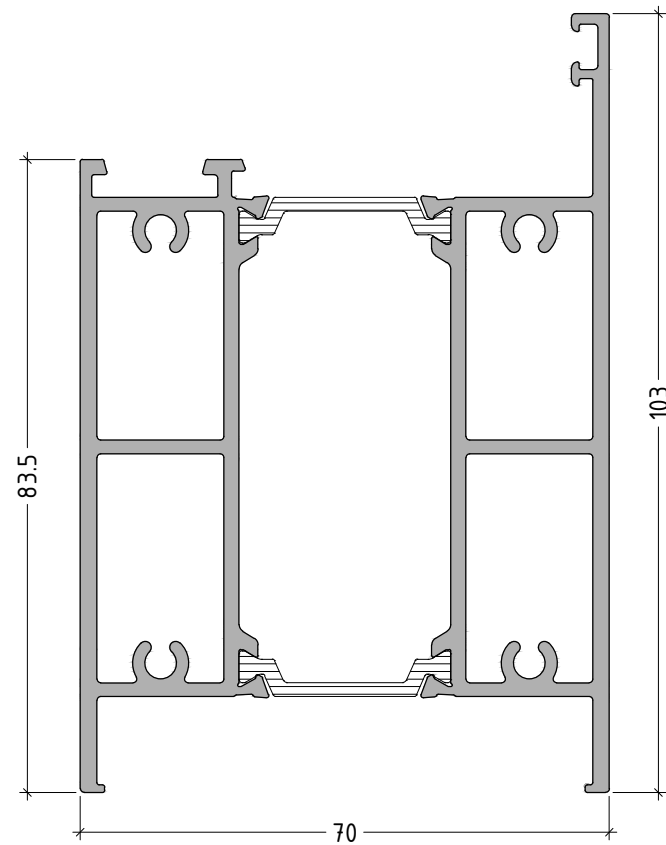

E6270150
Hotel type rail
2731 g/m

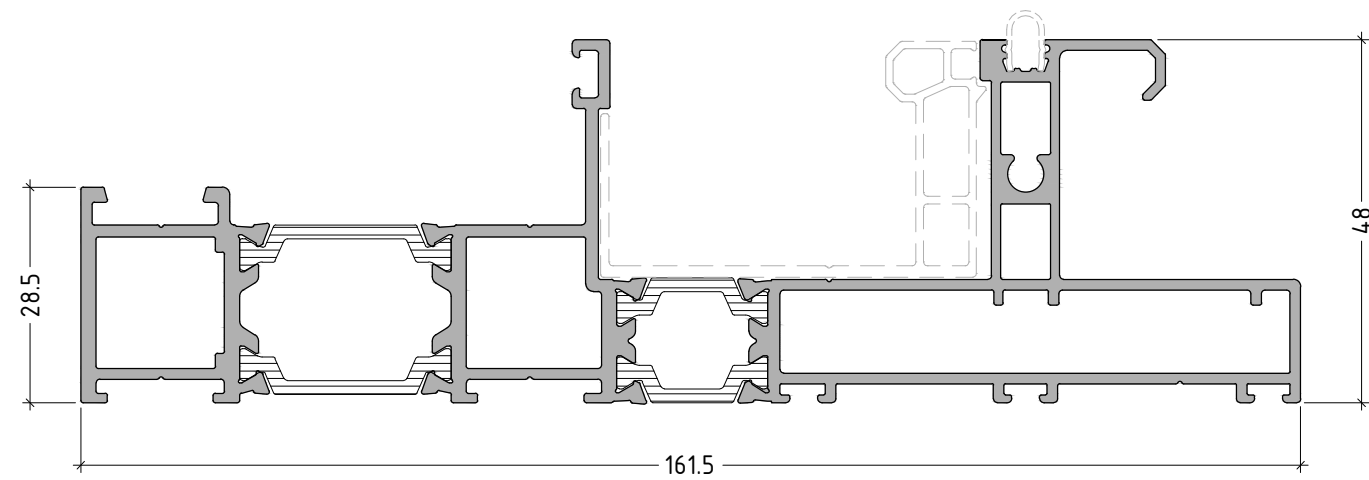

scale : 1:1

ES70.P-07

E6270510
Adjoining profile
1255 g/m

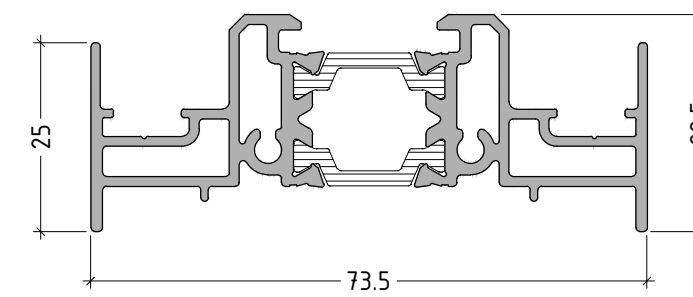

E6270501
Interlock profile
456 g/m

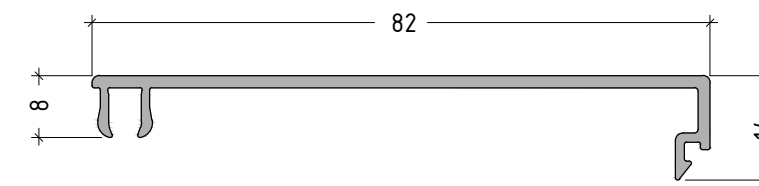

scale : 1:1

ES70.P-08

E6270520

Adjoining corner
profile for 90°

2511 g/m

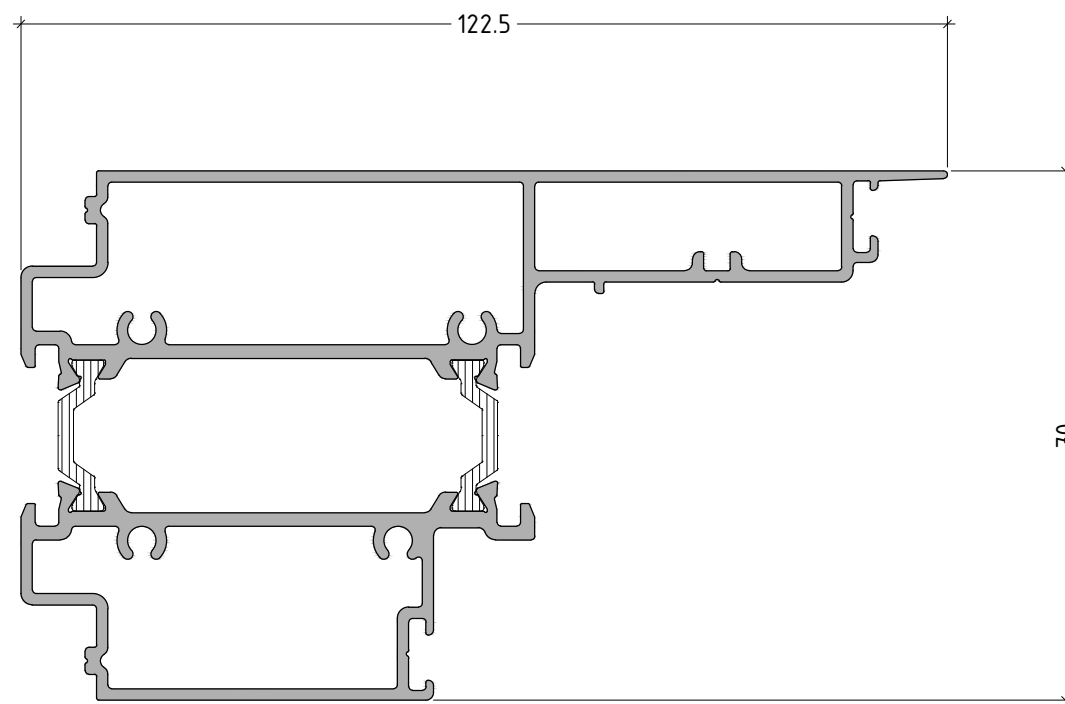

scale : 1:1

ES70-P-09

E6270650

Hotel type cap

535 g/m

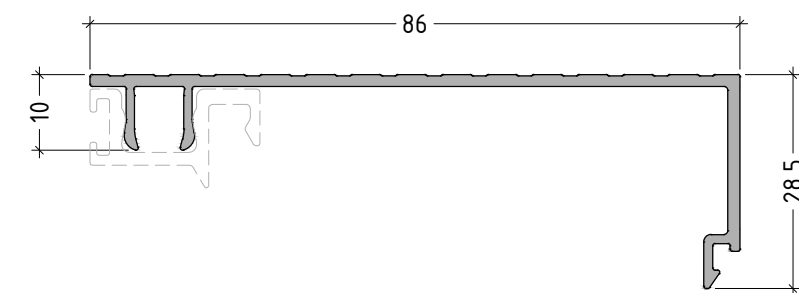

E6270620

Drip profile

410 g/m

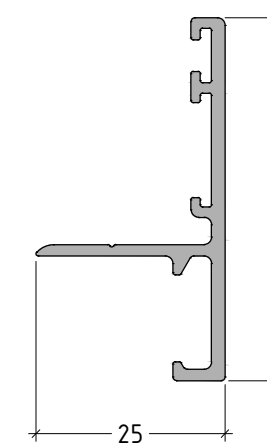

E6270695

Length connector for
E50 & ES70

224 g/m

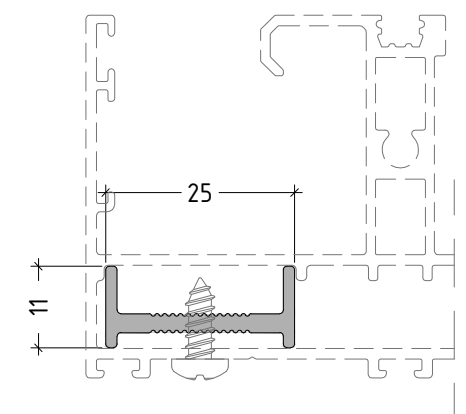

scale : 1:1

ES70-P-010

E6270680

Glazing bead

215 g/m

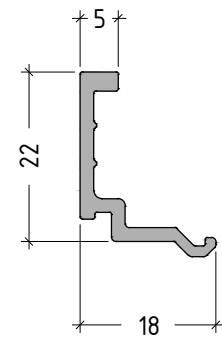

E6270681

Glazing bead

284 g/m

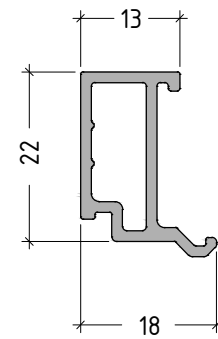

E6270682

Glazing bead

300 g/m

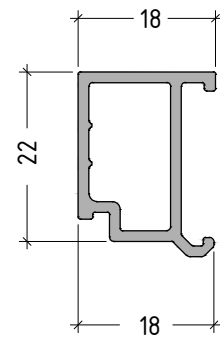

E6270684

Glazing bead

328 g/m

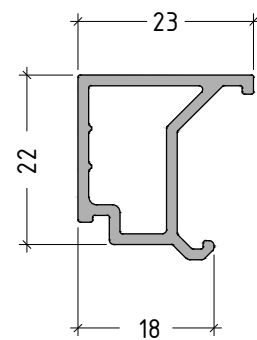

E6270683

Glazing bead

340 g/m

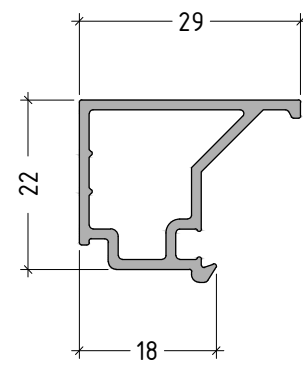

scale : 1:1

ES70.P-011

E6270690

Connector for
slide-fixed

2016 g/m

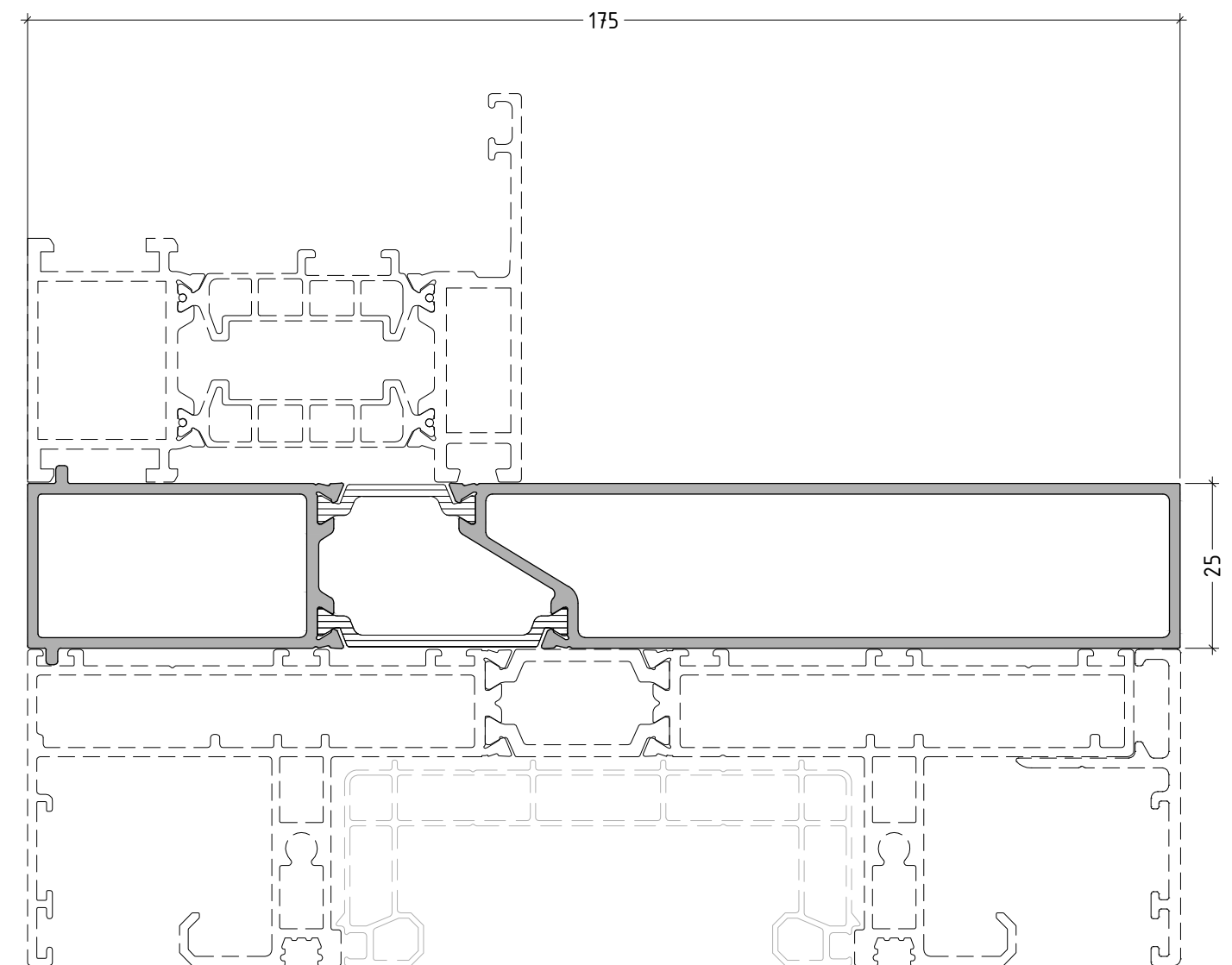

scale : 1:1

ES70.P-012

E50901W1

Aluminium drainage grill
(available only perforated)

124 g/m

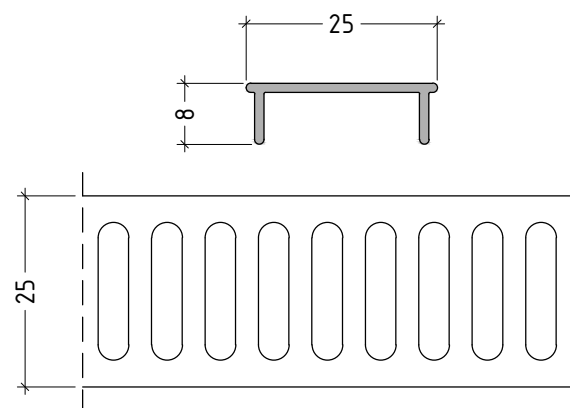

E6270220

Screen sash
for flat rail

1112 g/m

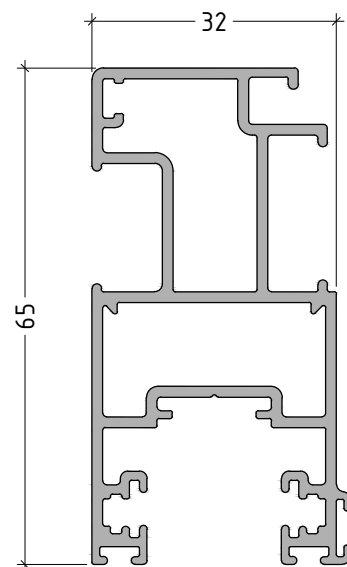

E6270902

Connecting rod

389 g/m

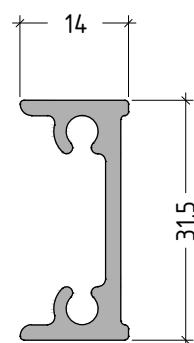

E6270904

Connecting rod
(for narrow sash)

186 g/m

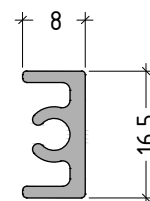

scale : 1:1

ES70.P-013

E22214

Fly-screen sash

857 g/m

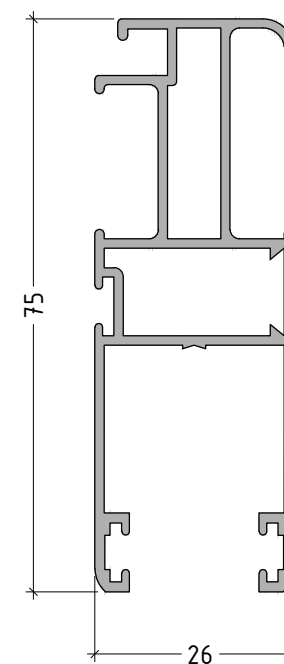

E22215

"T" profile
for fly screen

591 g/m

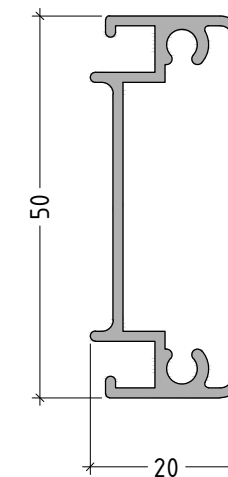

E22216

Vertical screen sash

732 g/m

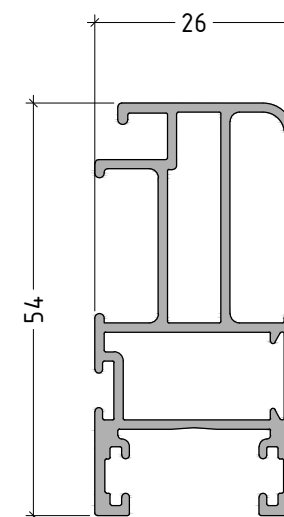

E19651

Cover for fly screen

100 g/m

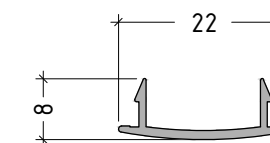

E22616

Cover for fly screen
E22216

105 g/m

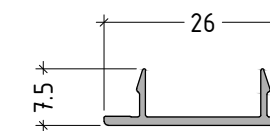

scale : 1:1

ES70.P-014

SECTIONS

SECTIONS / DETAILS

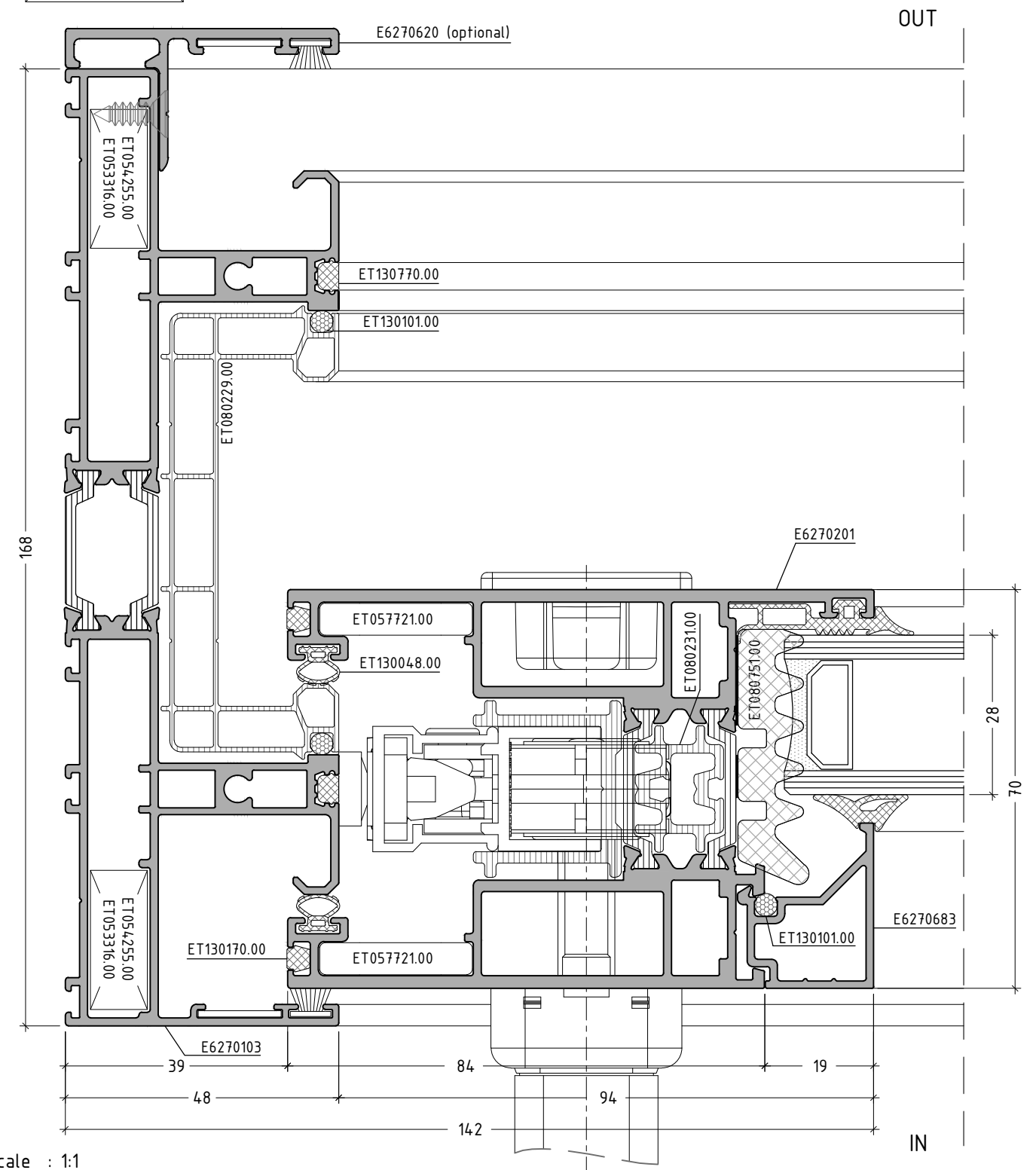
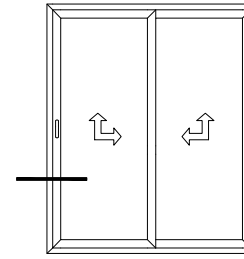

scale : 1:1

sliding system with thermal break

ES70

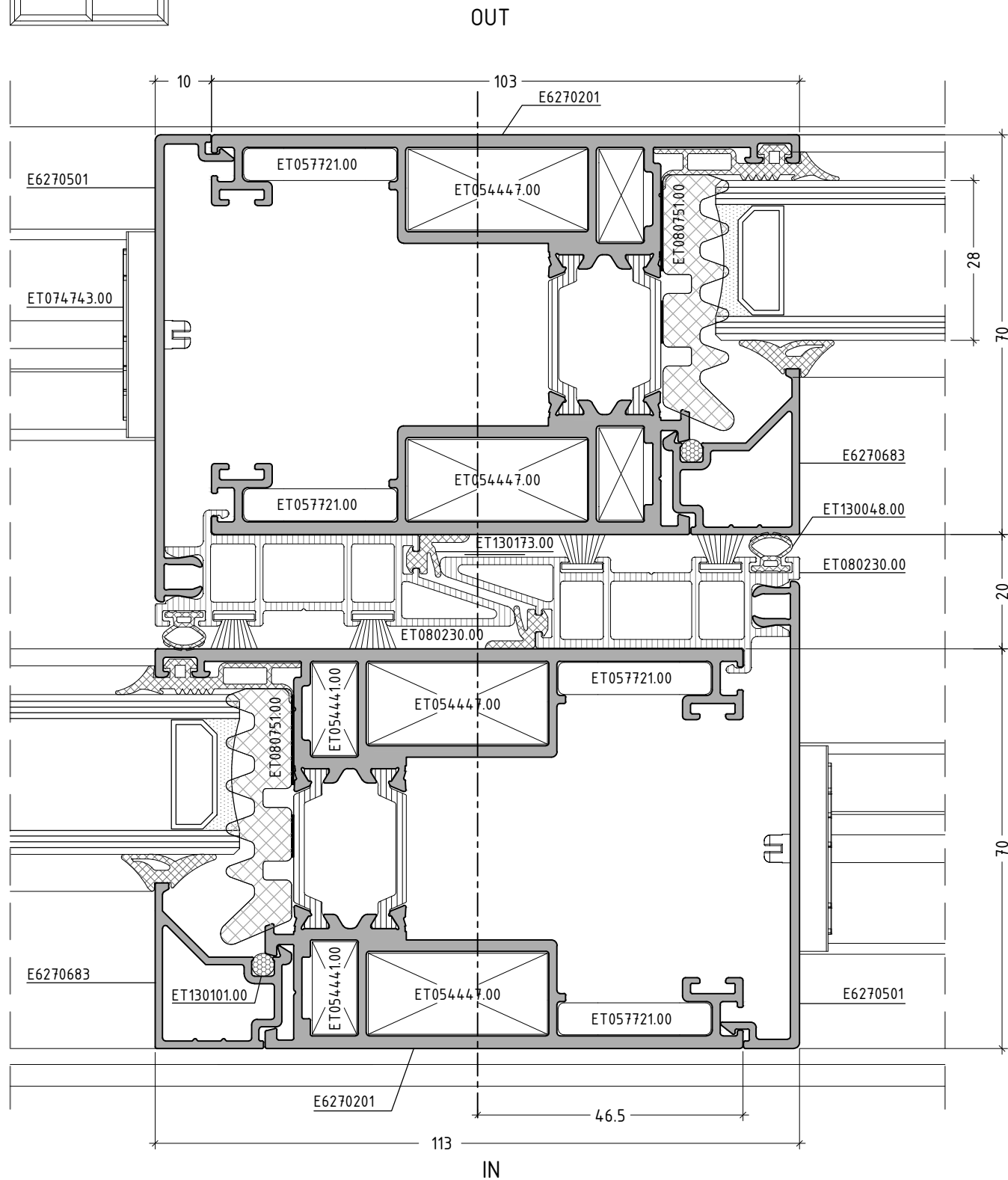
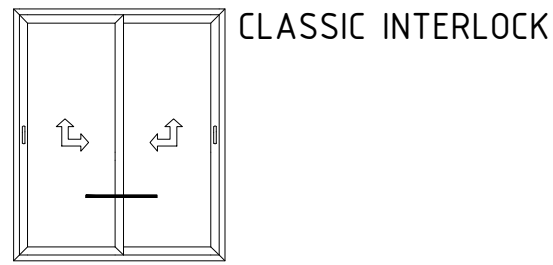

scale : 1:1

ES70.S-02

sliding system with thermal break

ES70

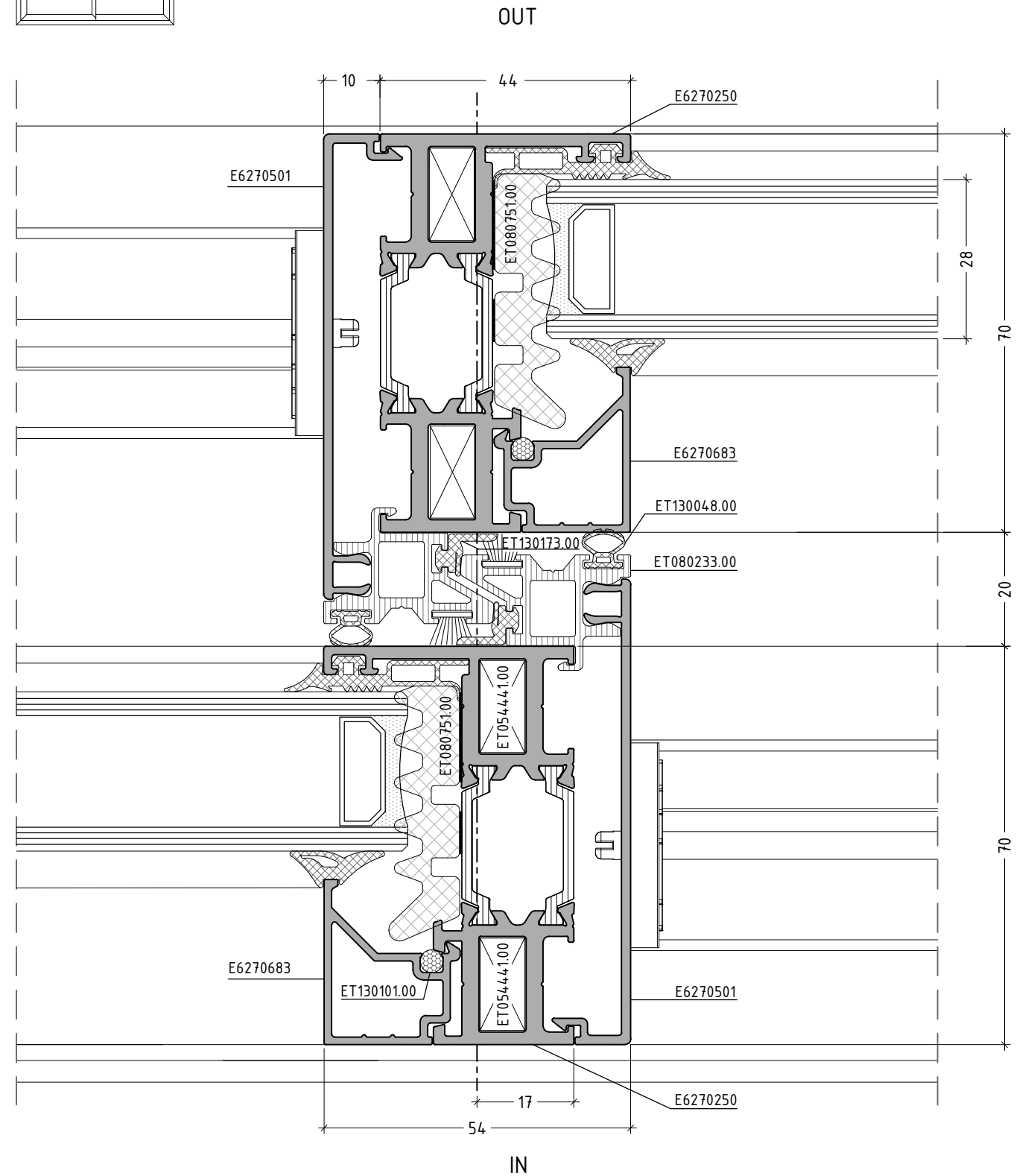
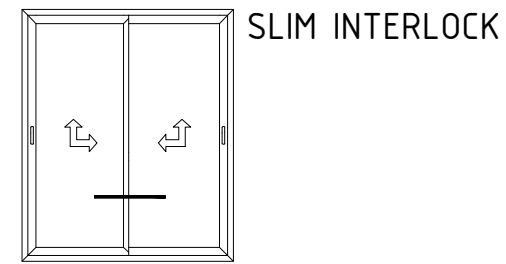

scale : 1:1

ES70.S-03

sliding system with thermal break

ES70

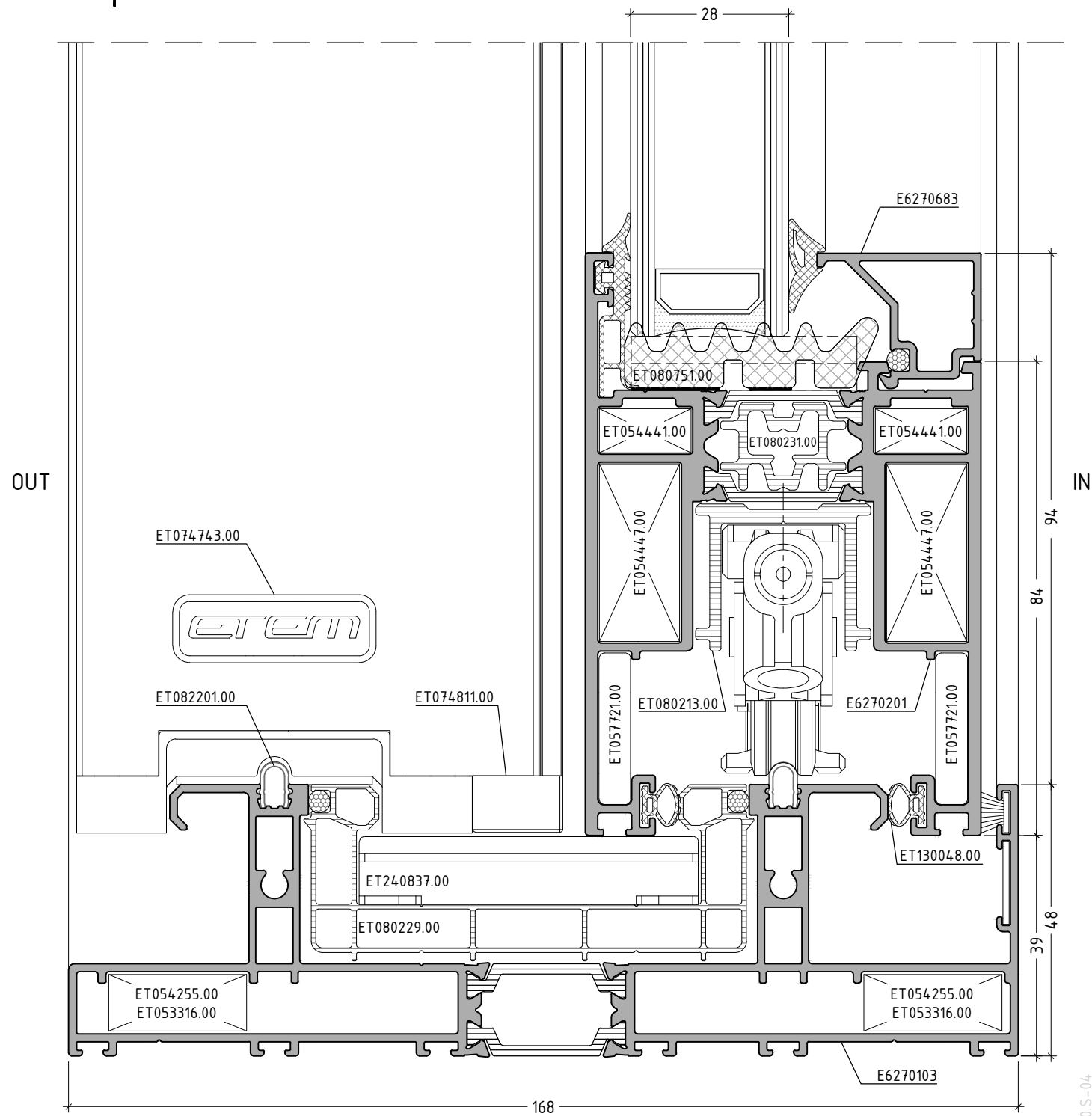
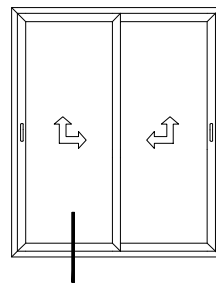

scale : 1:1

ES70.S-04

sliding system with thermal break

ES70

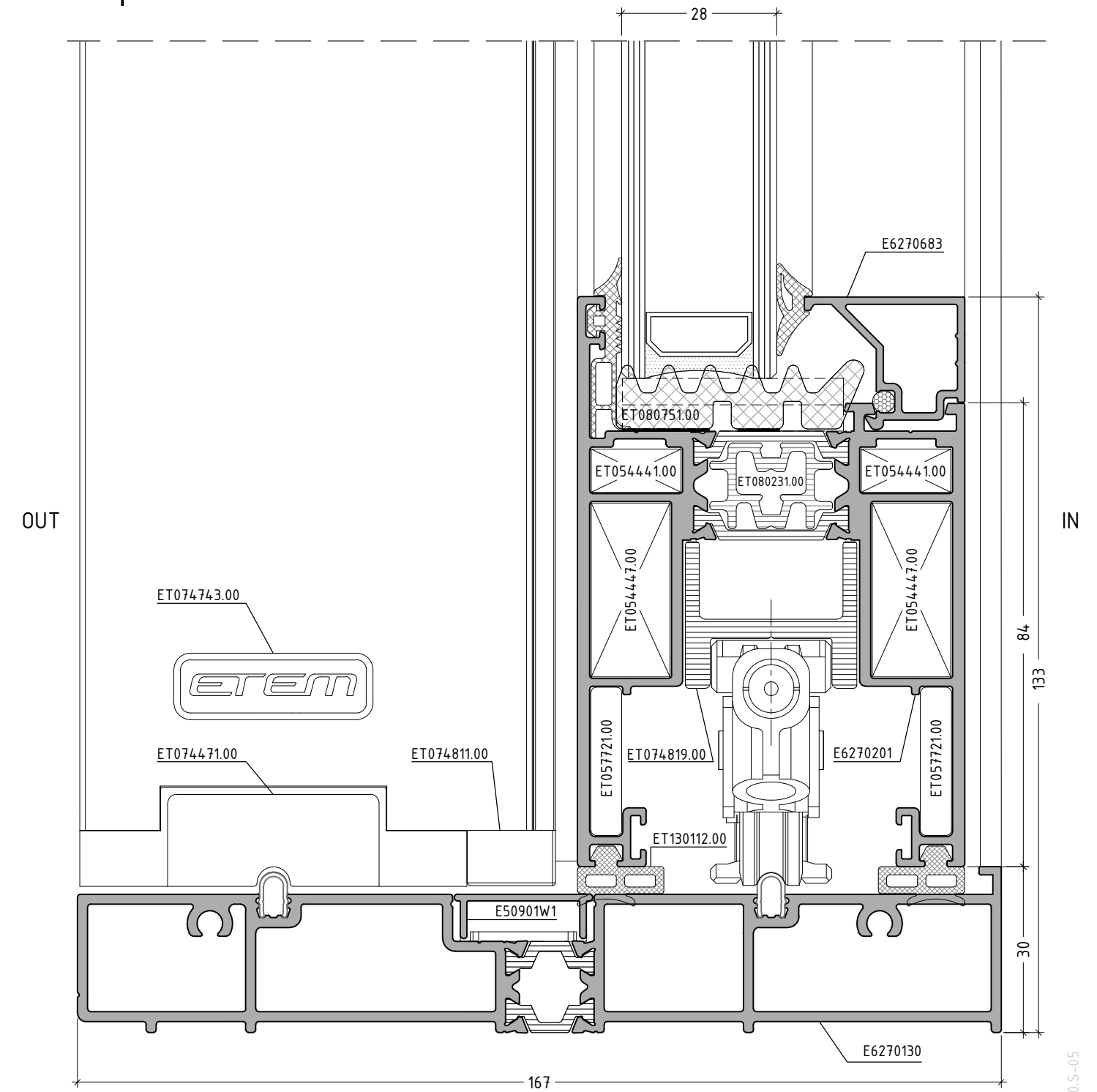
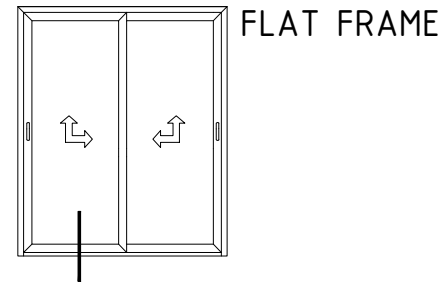

scale : 1:1

ES70.S-05

sliding system with thermal break

ES70

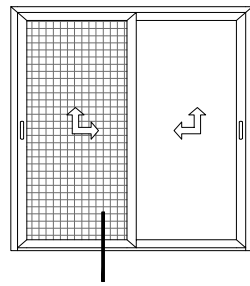

FLAT FRAME WITH FLY SCREEN

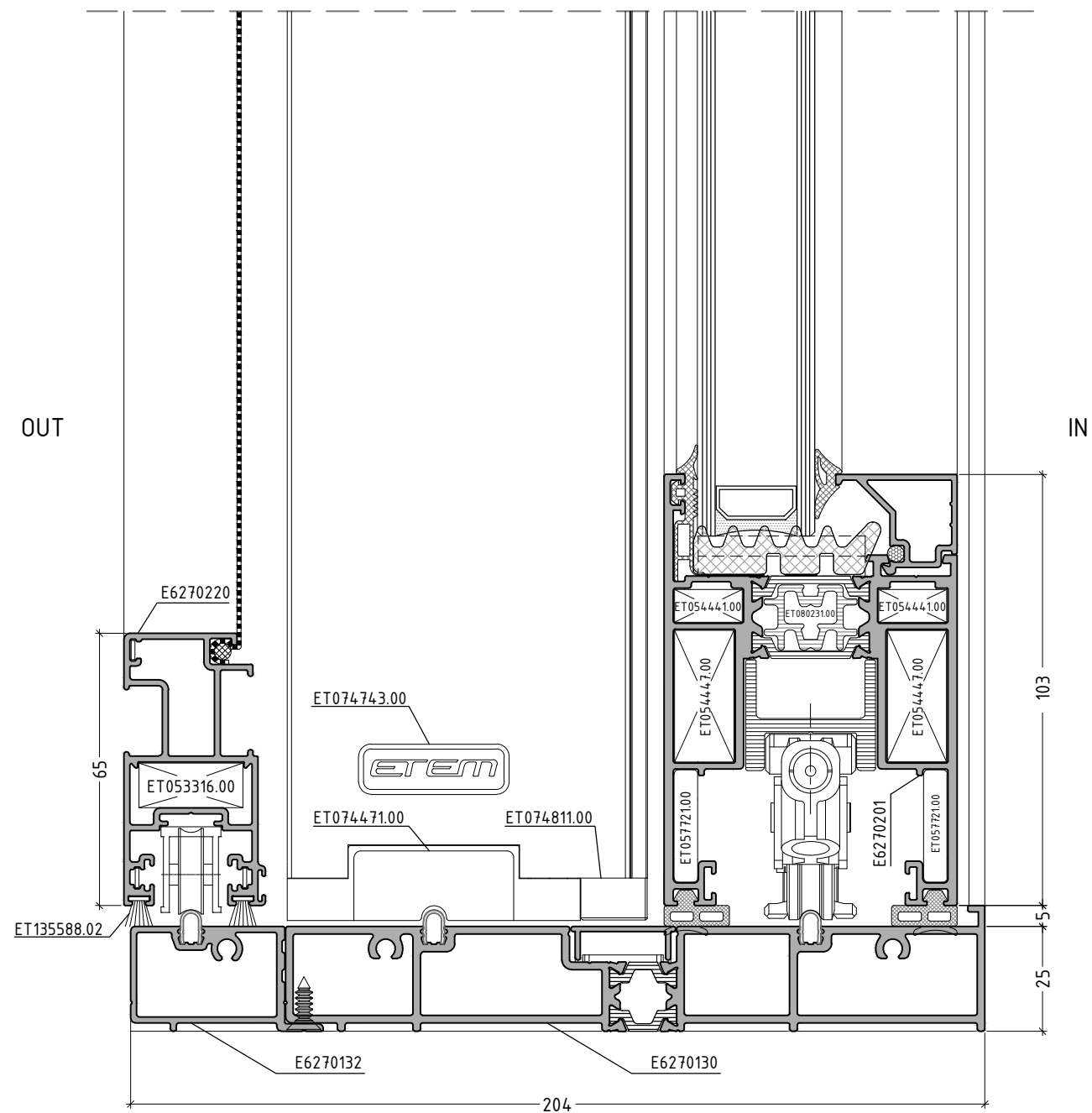

scale : 1:1.5

ES70.S-06

sliding system with thermal break

ES70

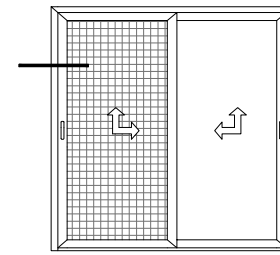

FLAT FRAME WITH FLY SCREEN

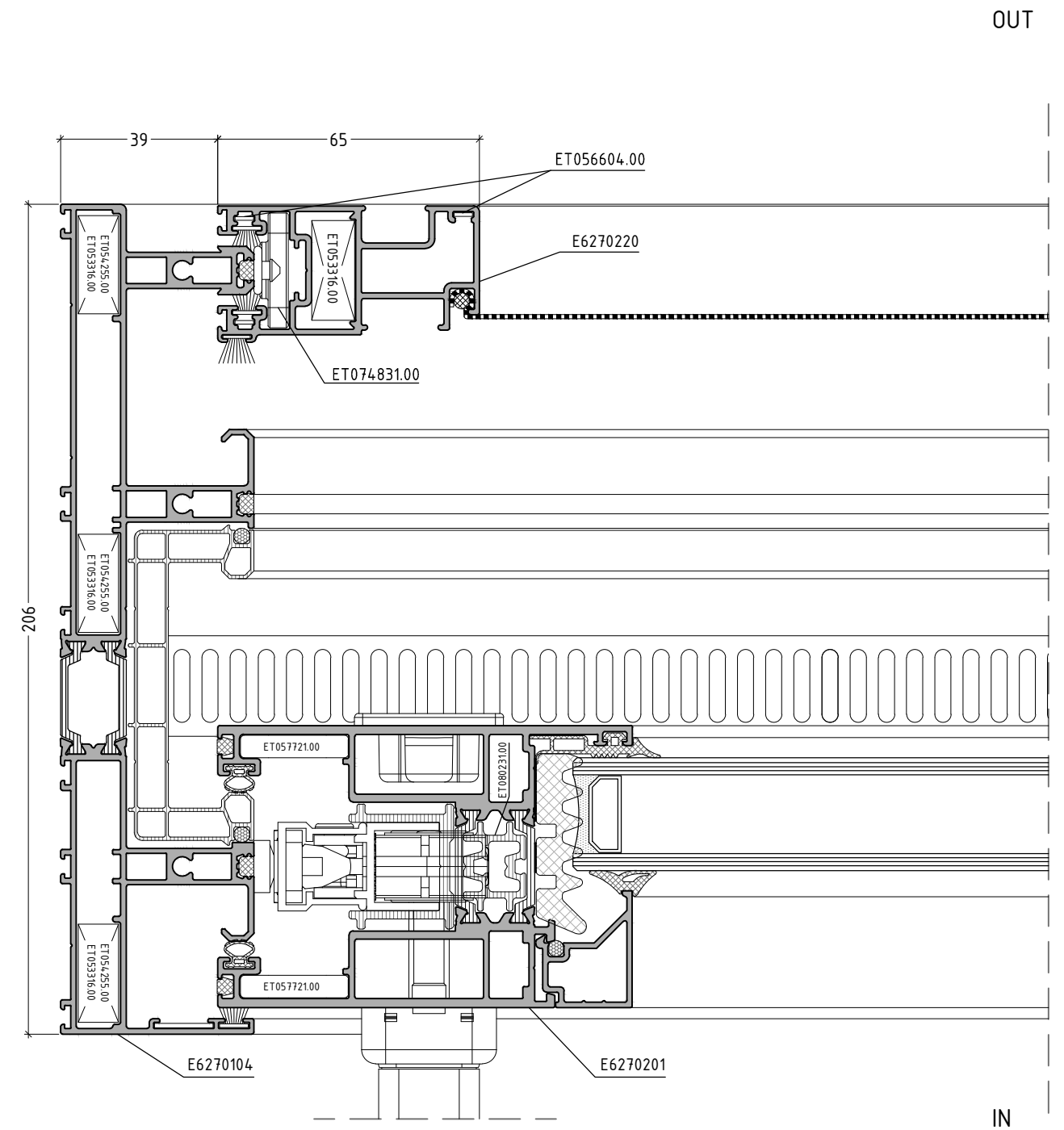

scale : 1:1.5

ES70.S-07

sliding system with thermal break

ES70

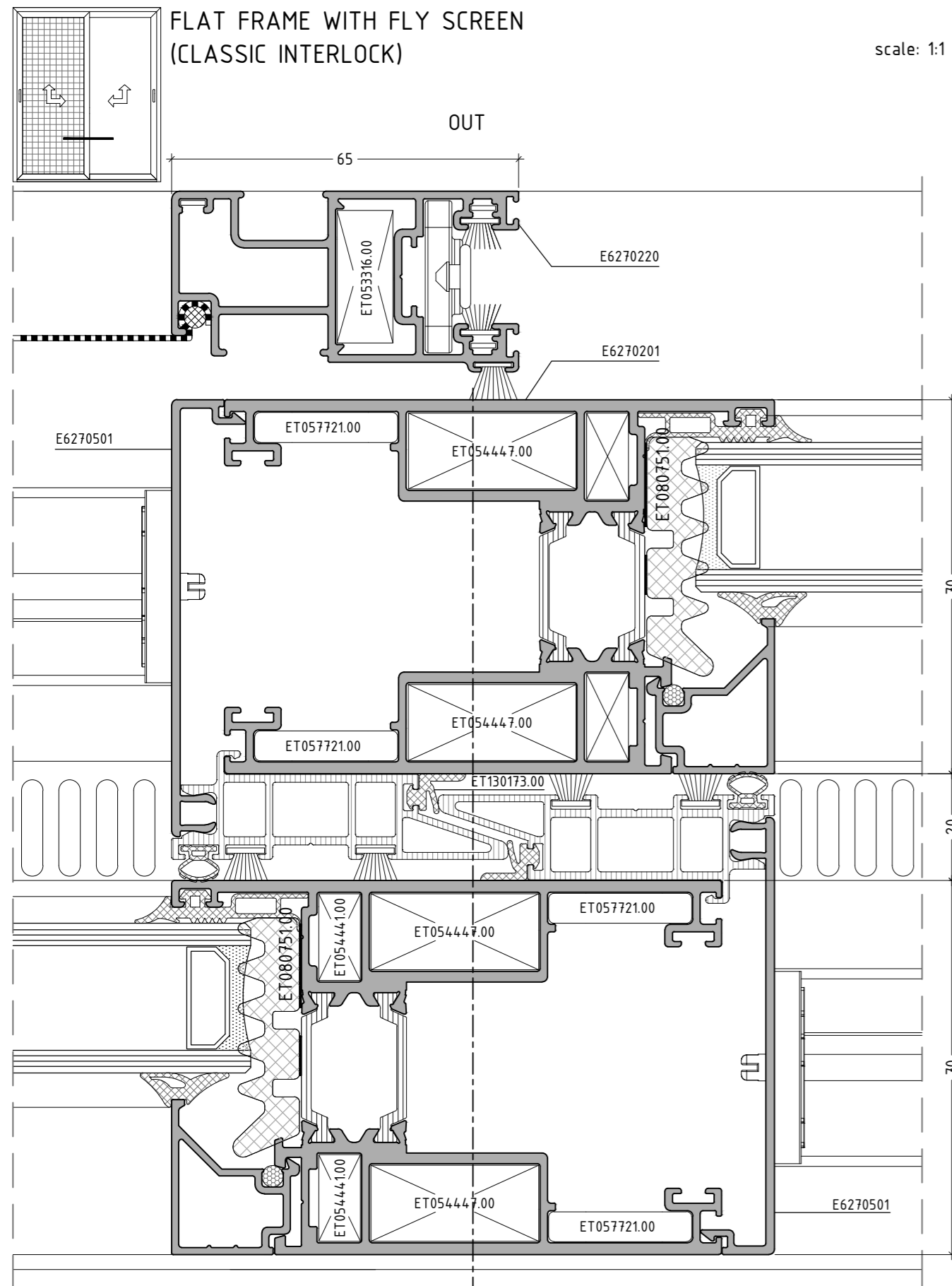

sliding system with thermal break

ES70

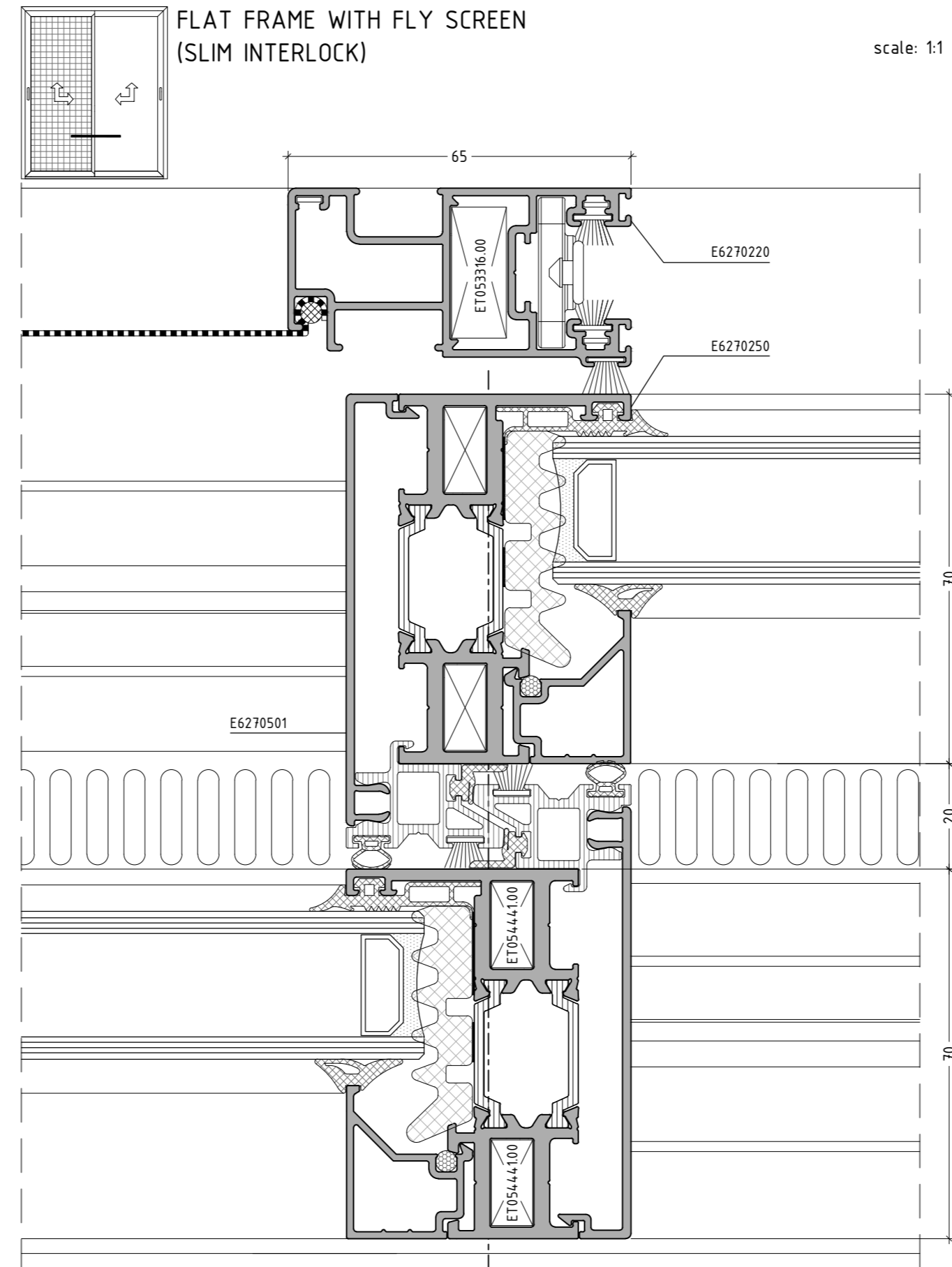

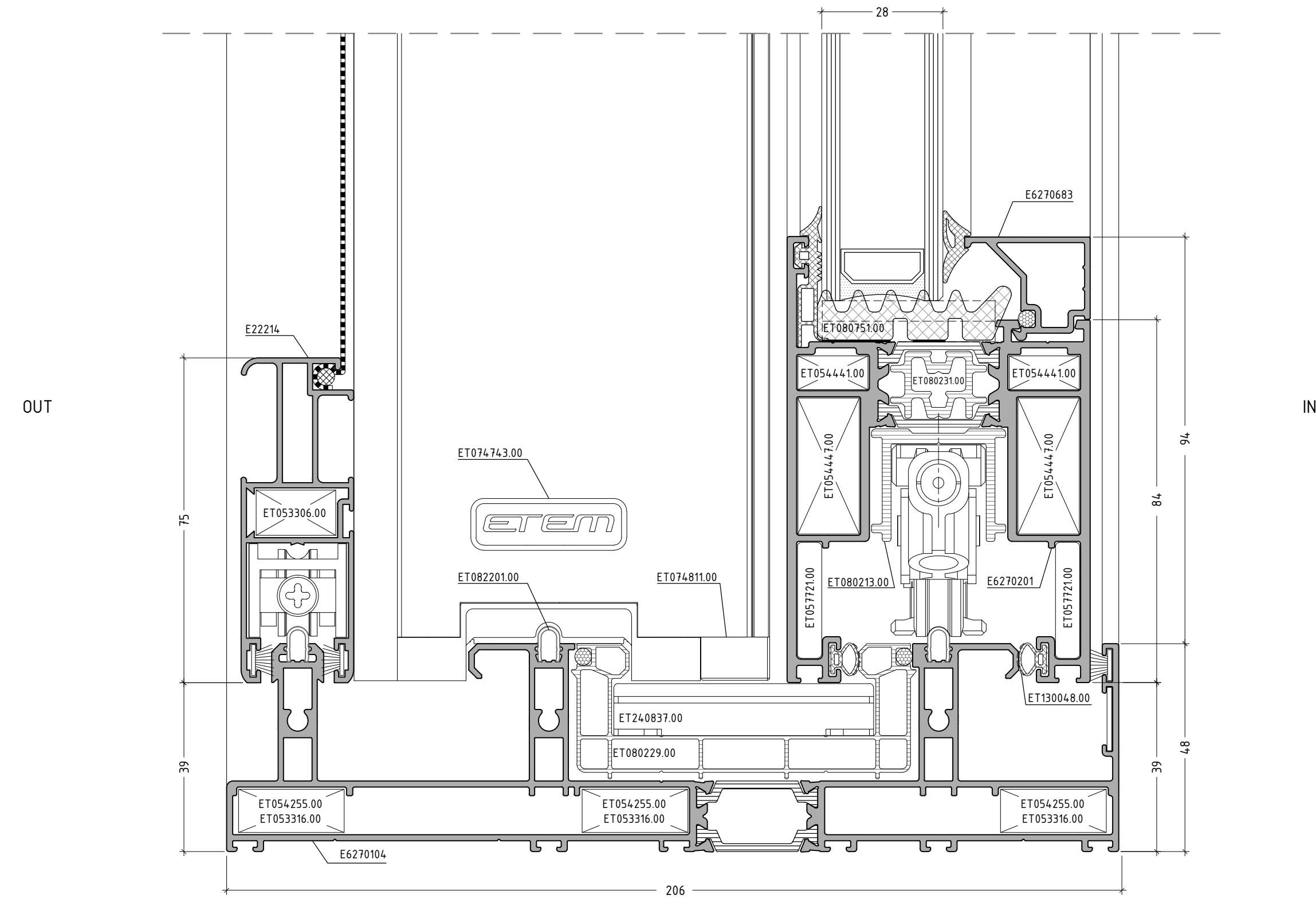
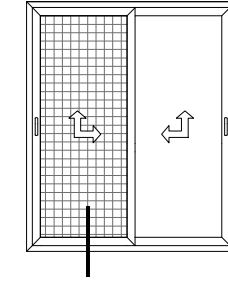

scale : 1:1

IN

ES70 S-010

scale: 1:1

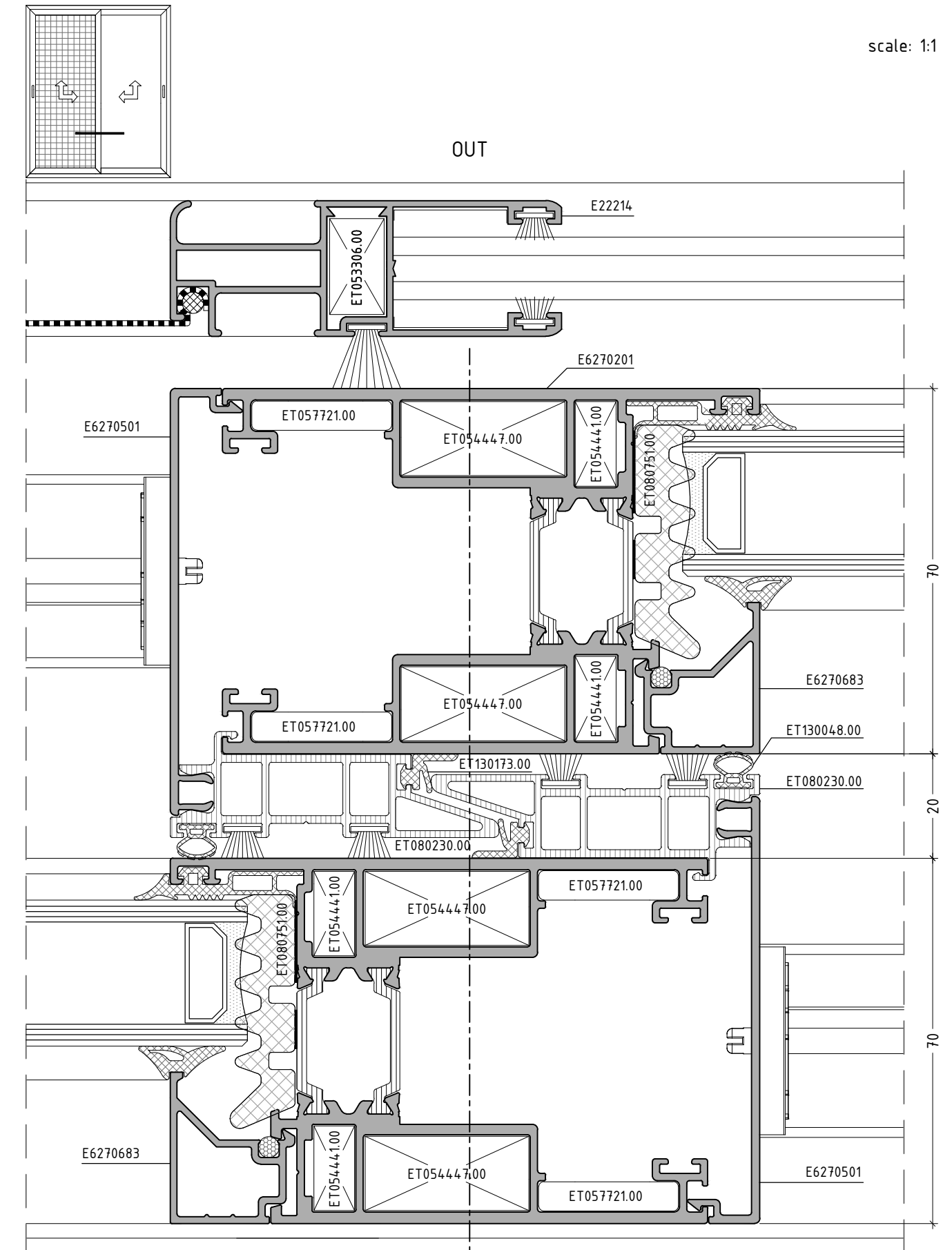

OUT

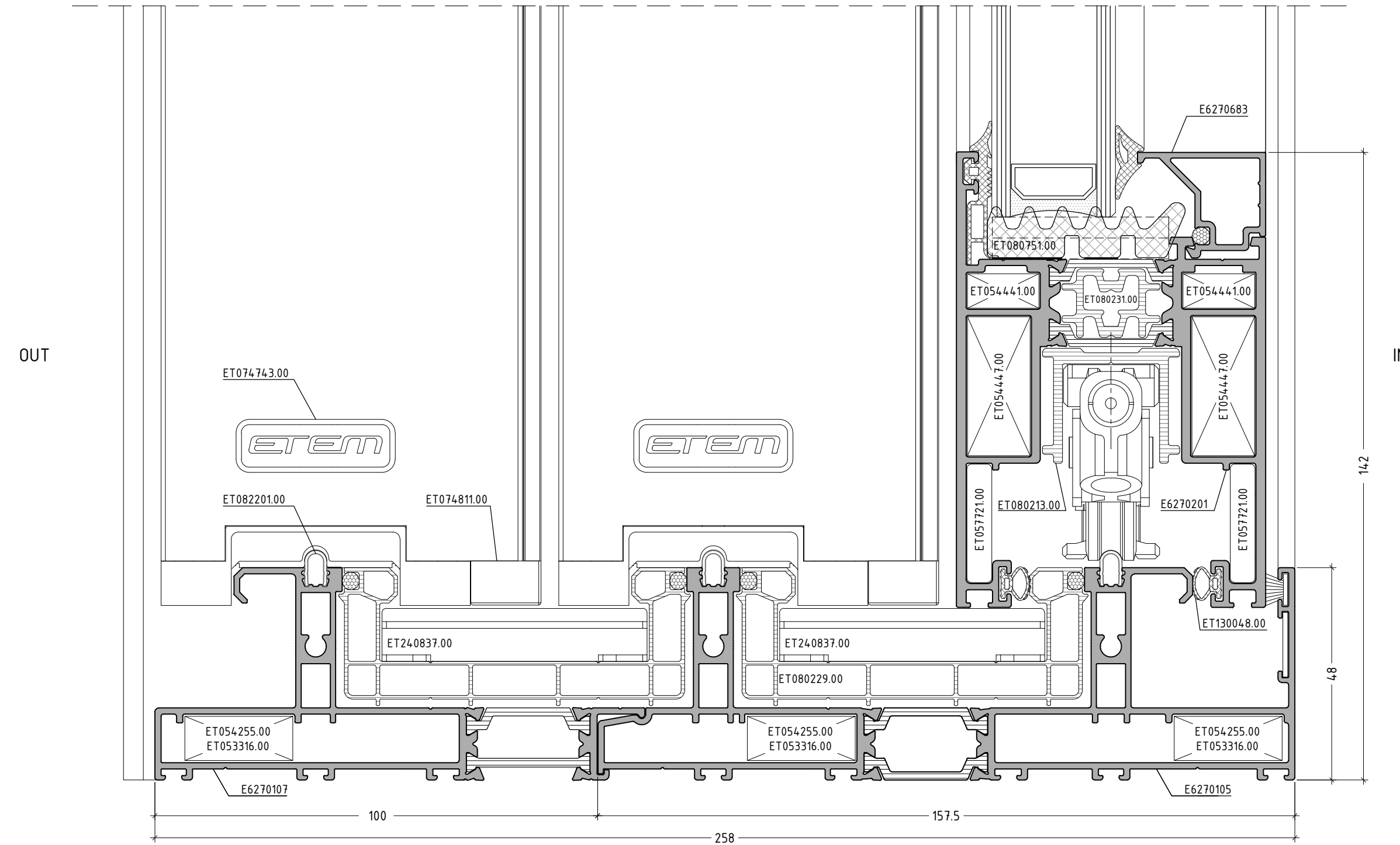
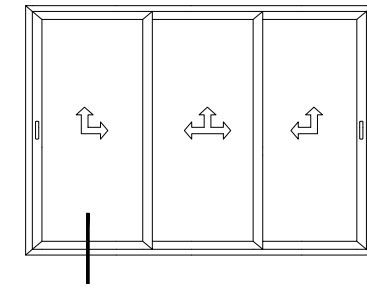

scale : 1:1

ES70.S-012

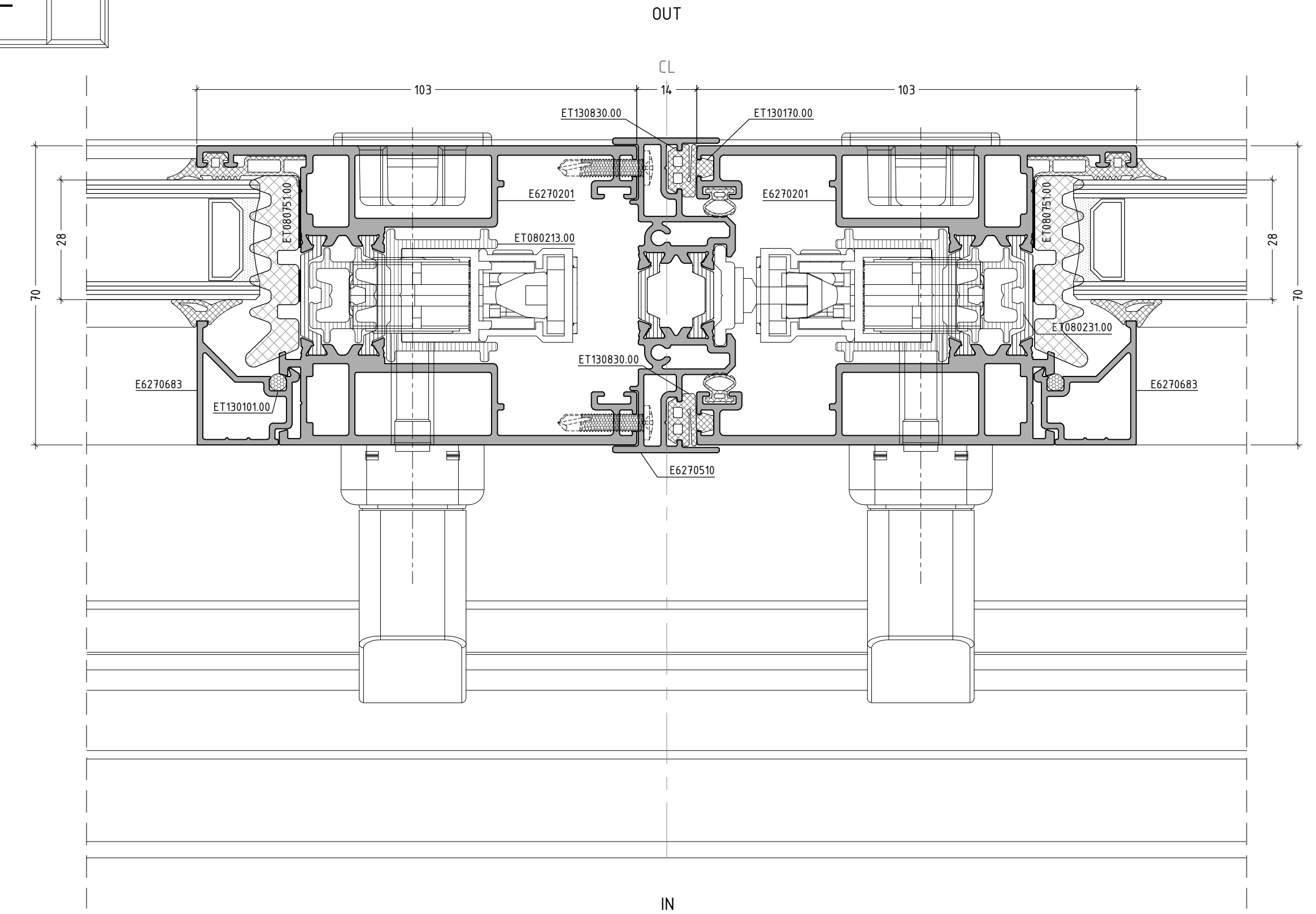
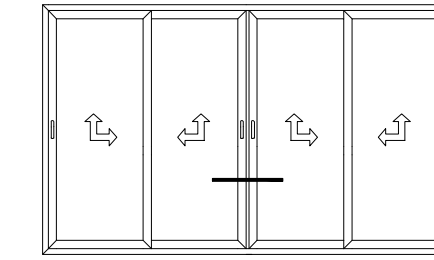

scale : 1:1

ES70.S-013

sliding system with thermal break

ES70

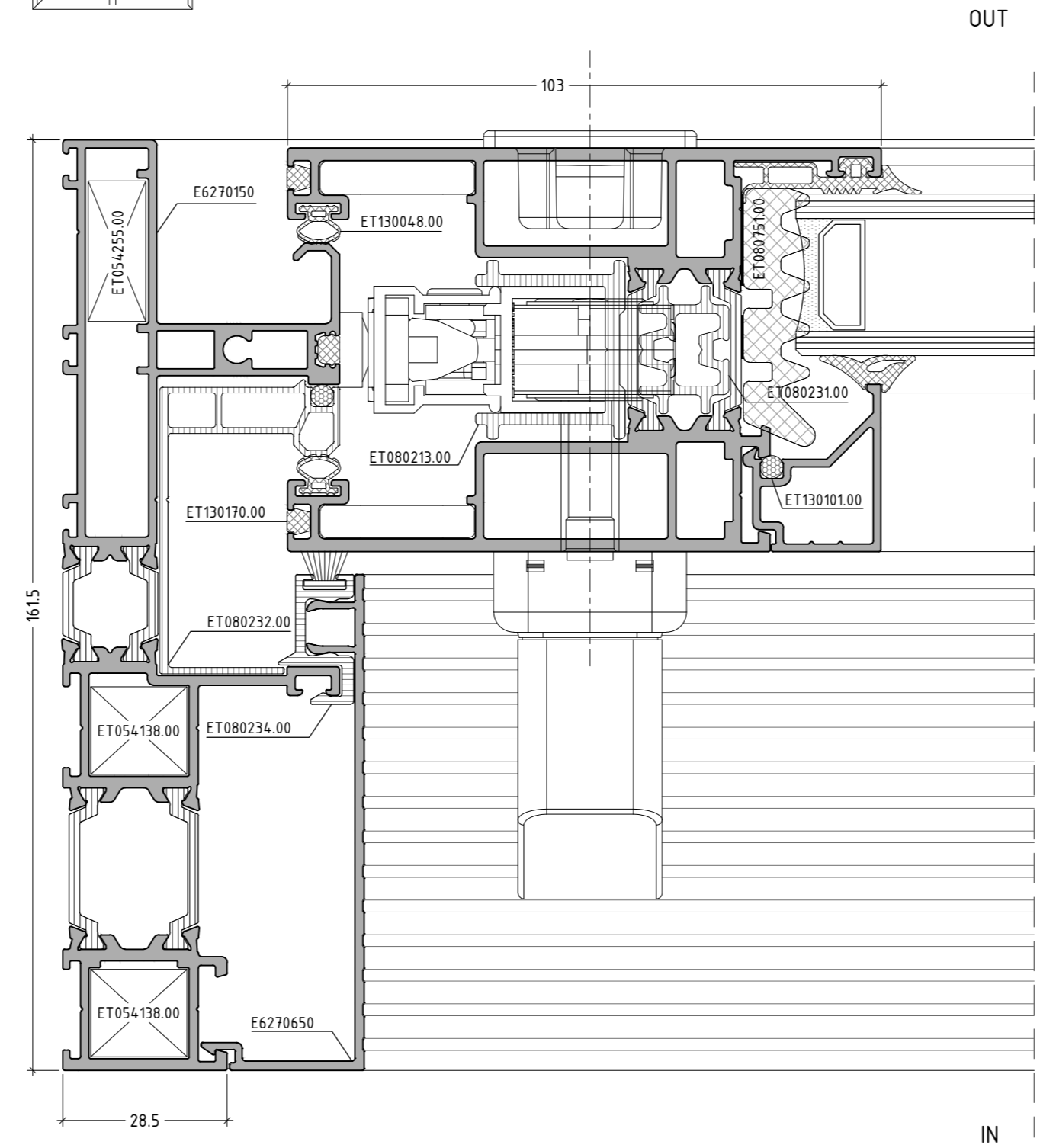
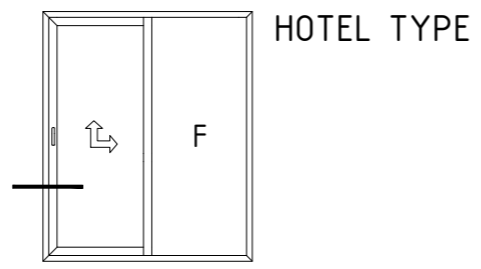

scale : 1:1

ES70.S-014

sliding system with thermal break

ES70

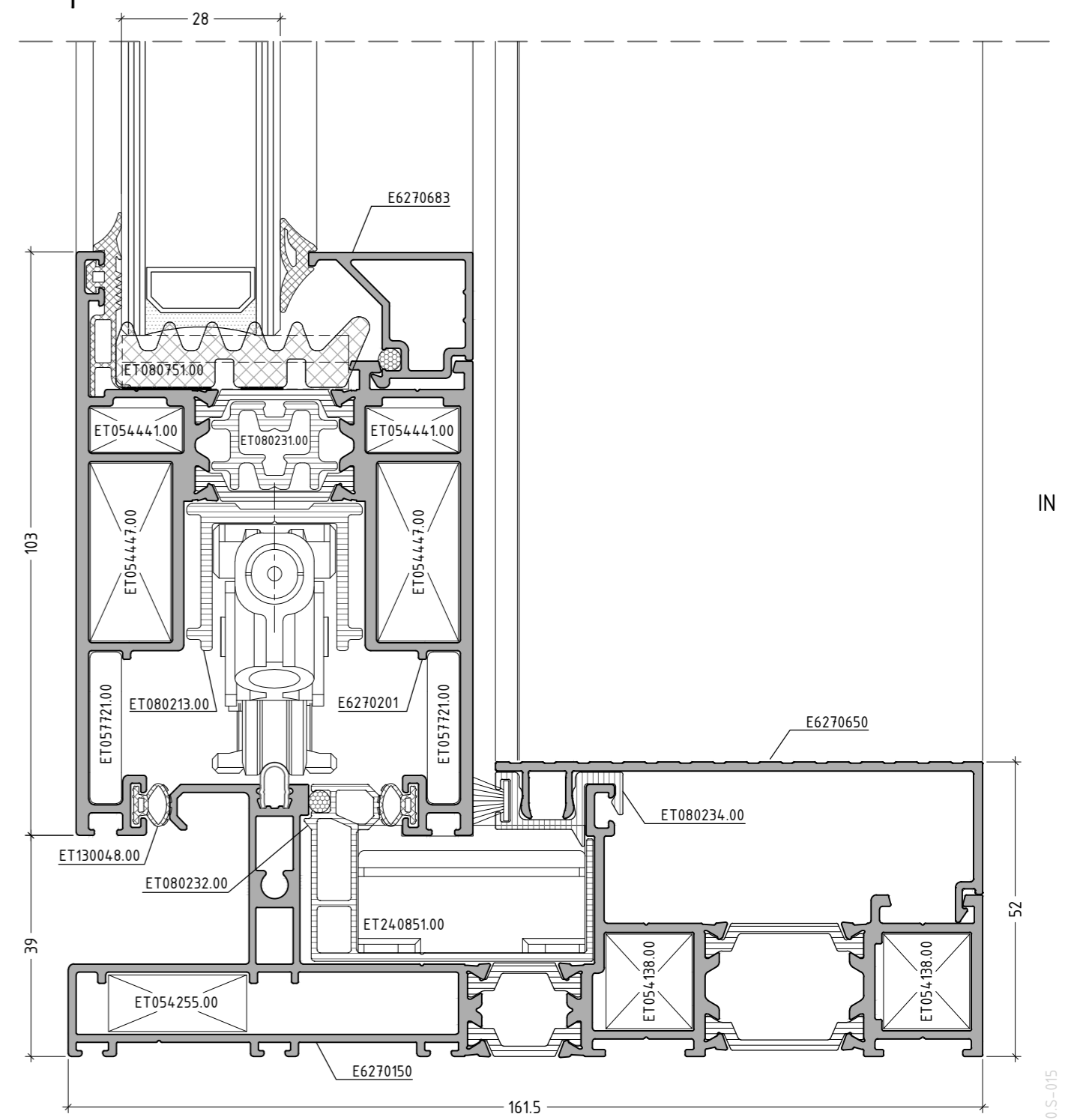
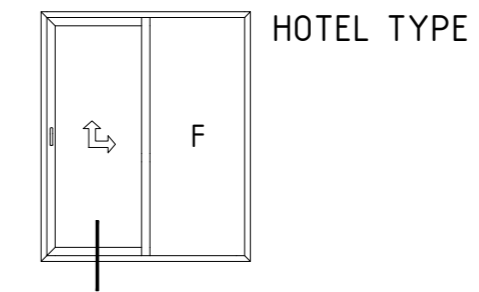

scale : 1:1

ES70.S-015

sliding system with thermal break

ES70

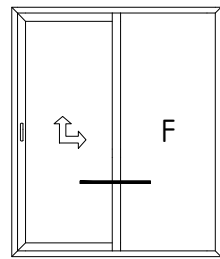

HOTEL TYPE

OUT

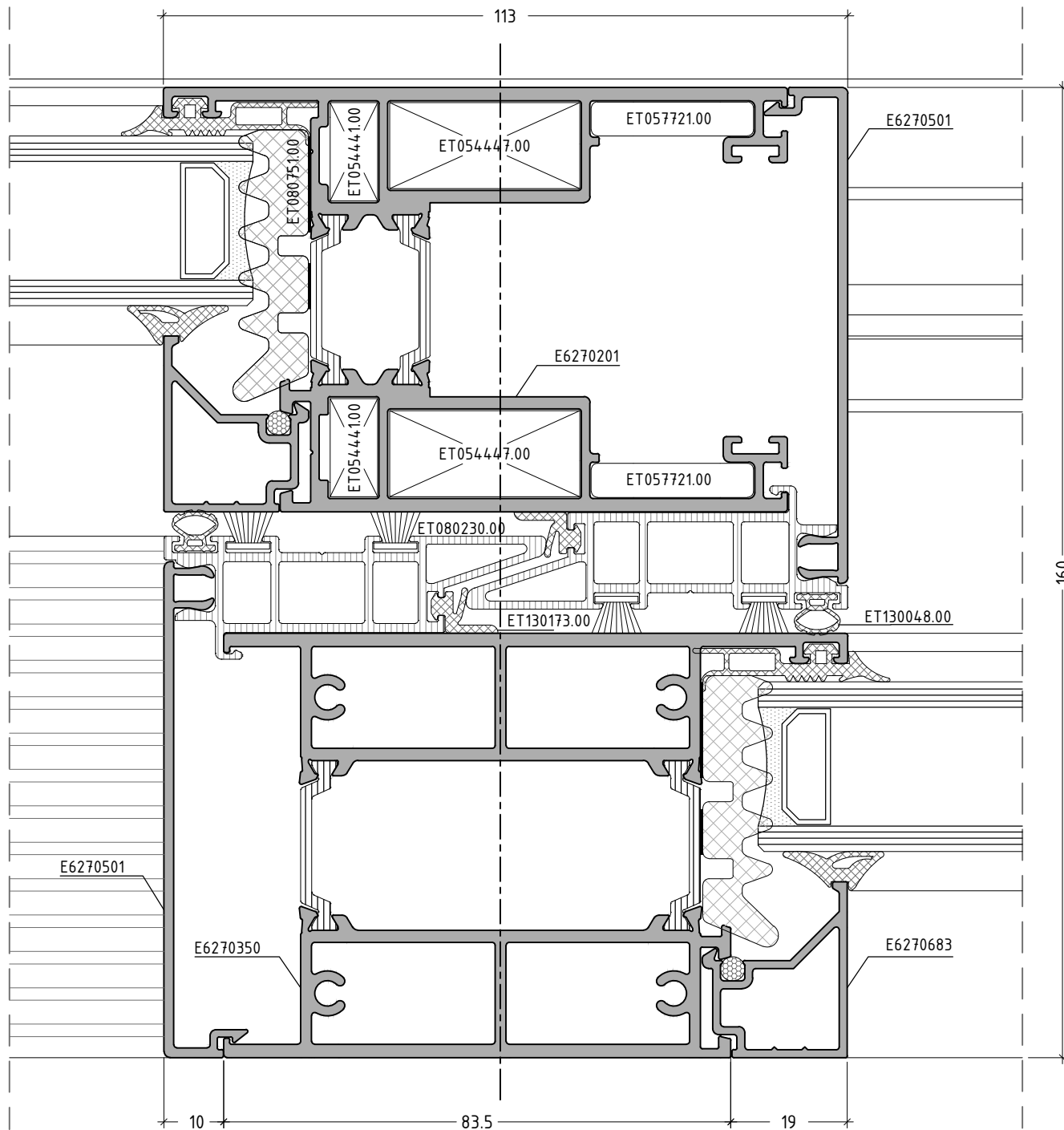

scale : 1:1

IN

ES70.S-016

sliding system with thermal break

ES70

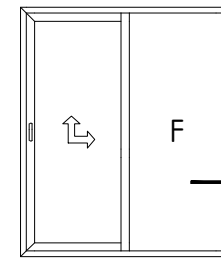

HOTEL TYPE

OUT

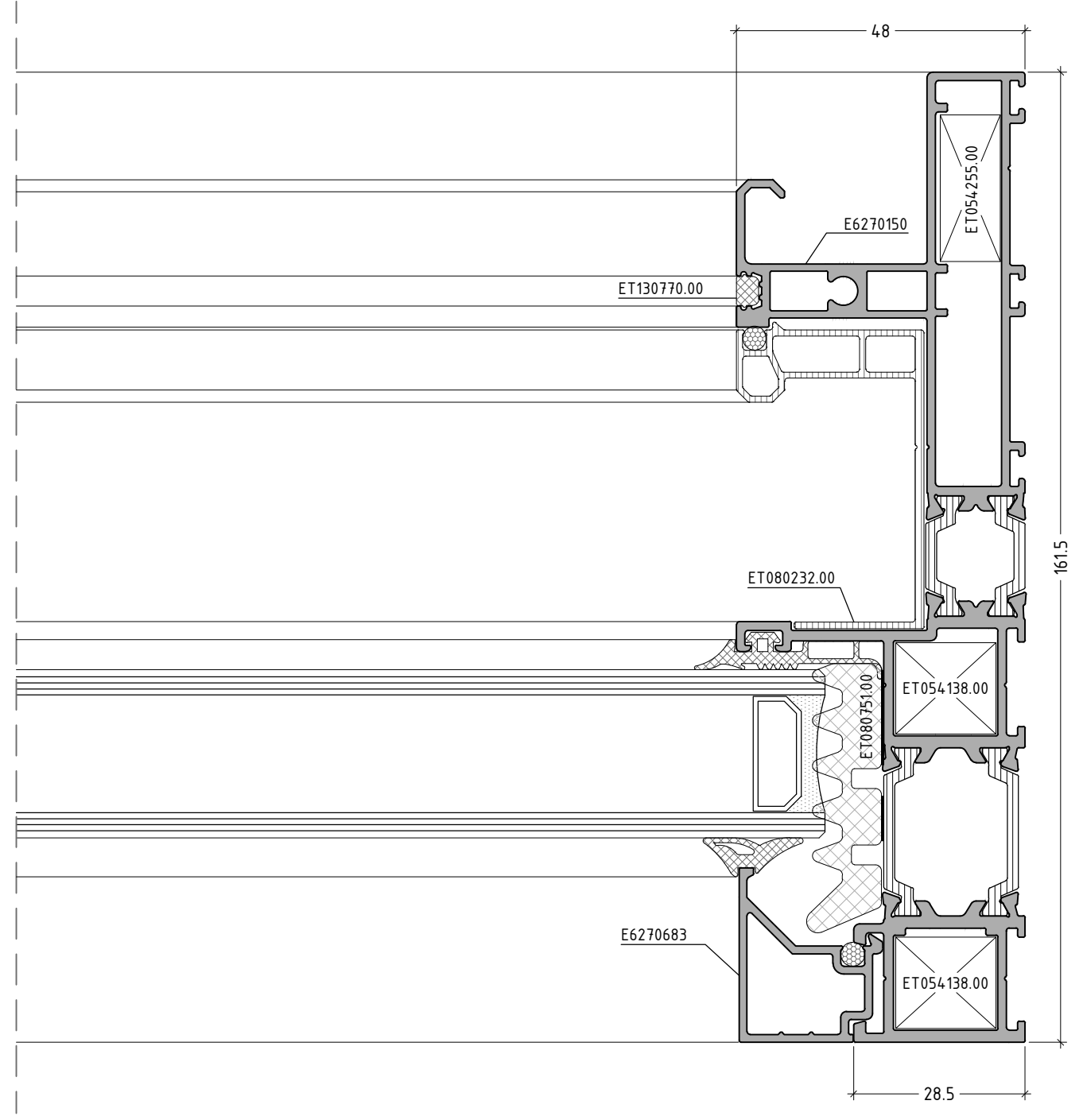

scale : 1:1

IN

ES70.S-017

sliding system with thermal break

ES70

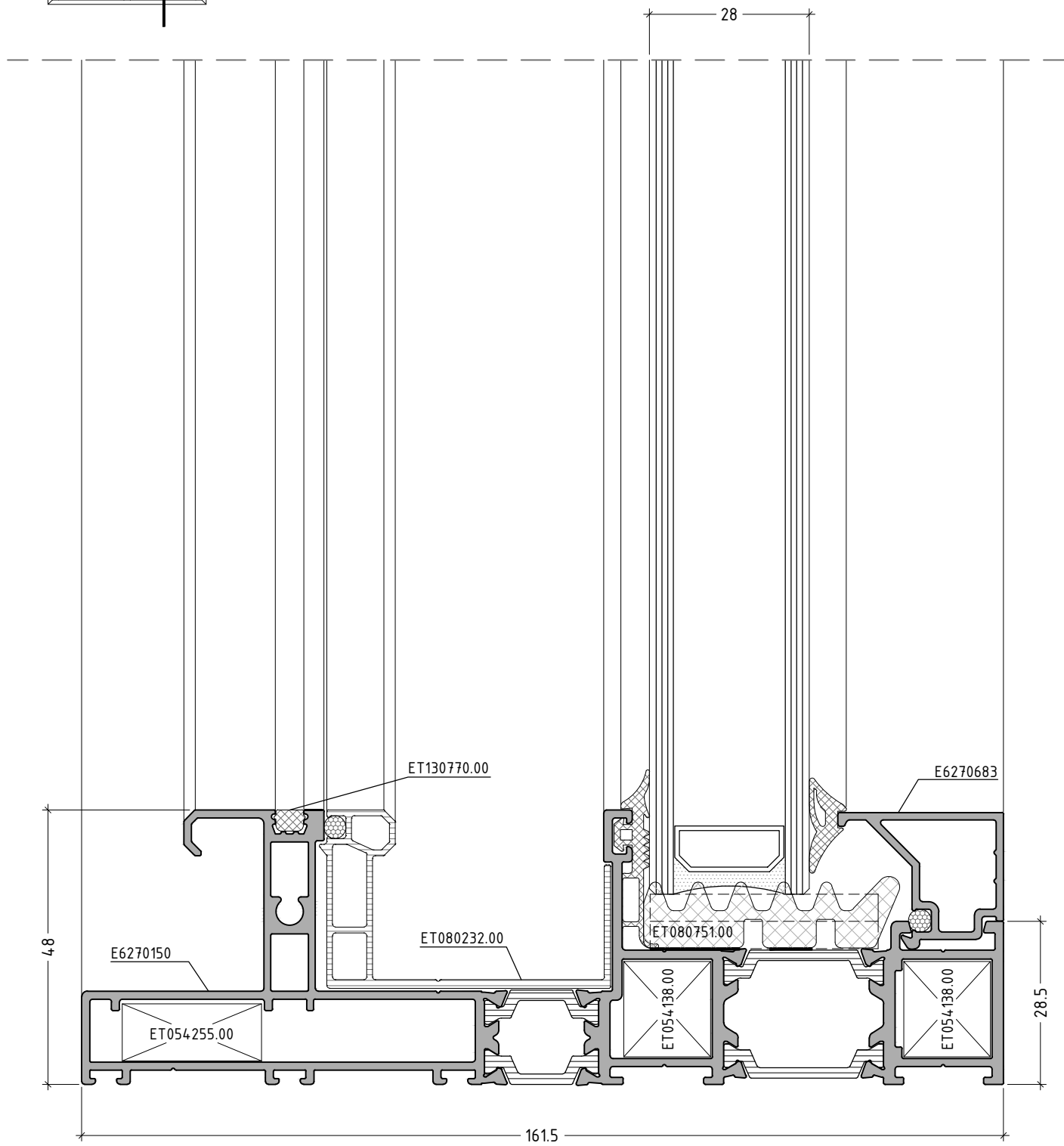
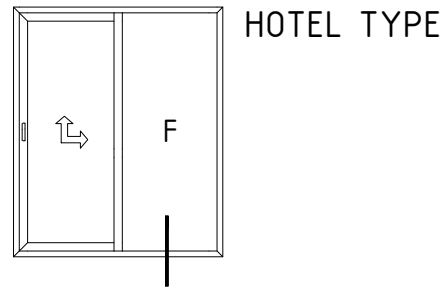

scale : 1:1

ES70.S-018

sliding system with thermal break

ES70

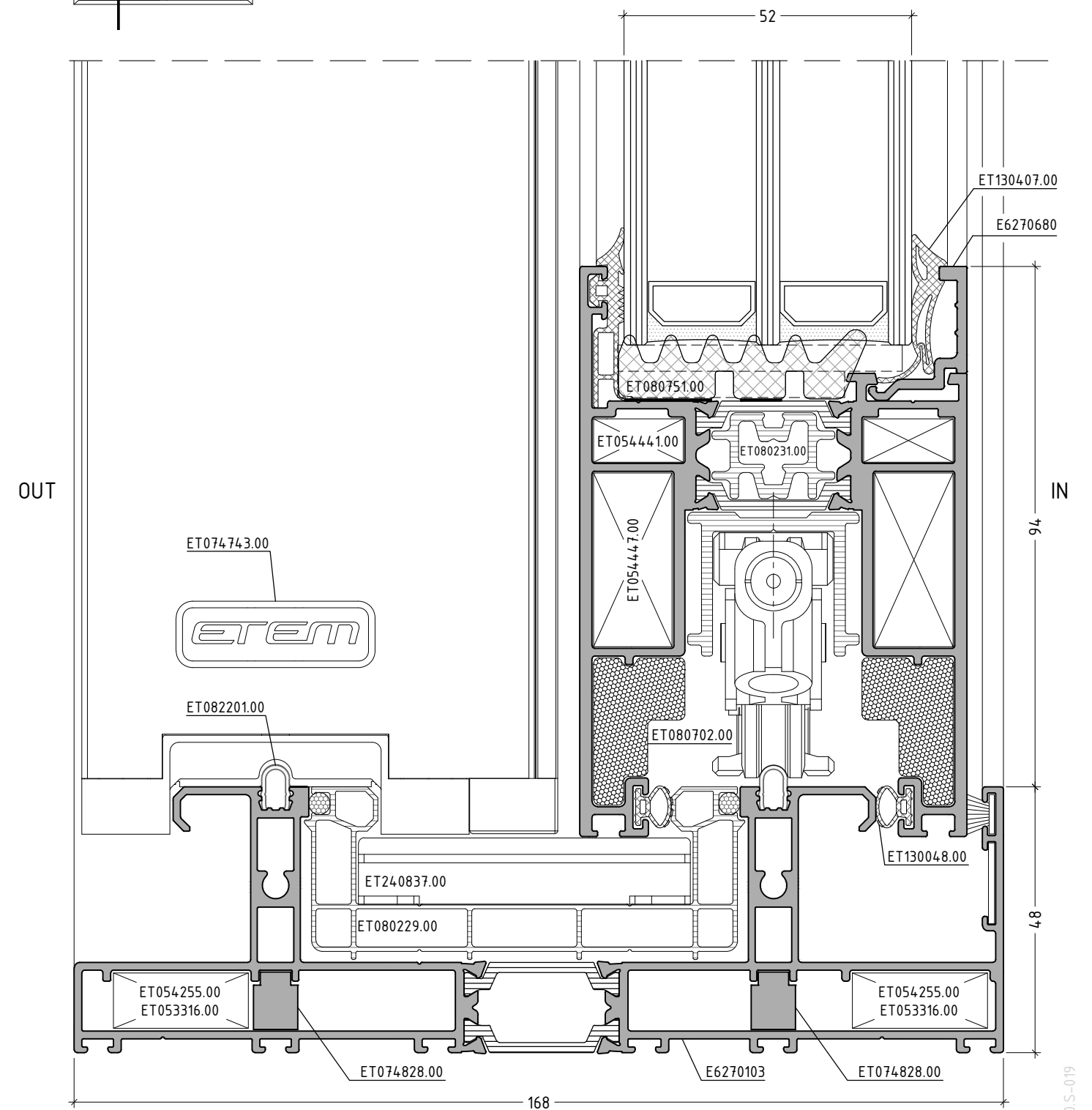
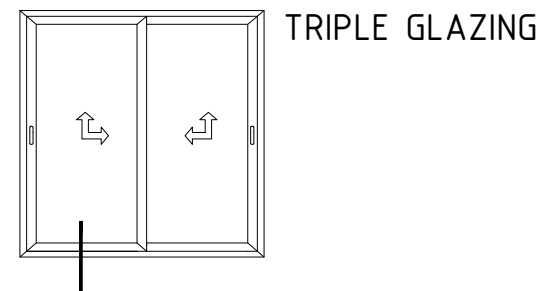

scale : 1:1

ES70.S-019

sliding system with thermal break

ES70

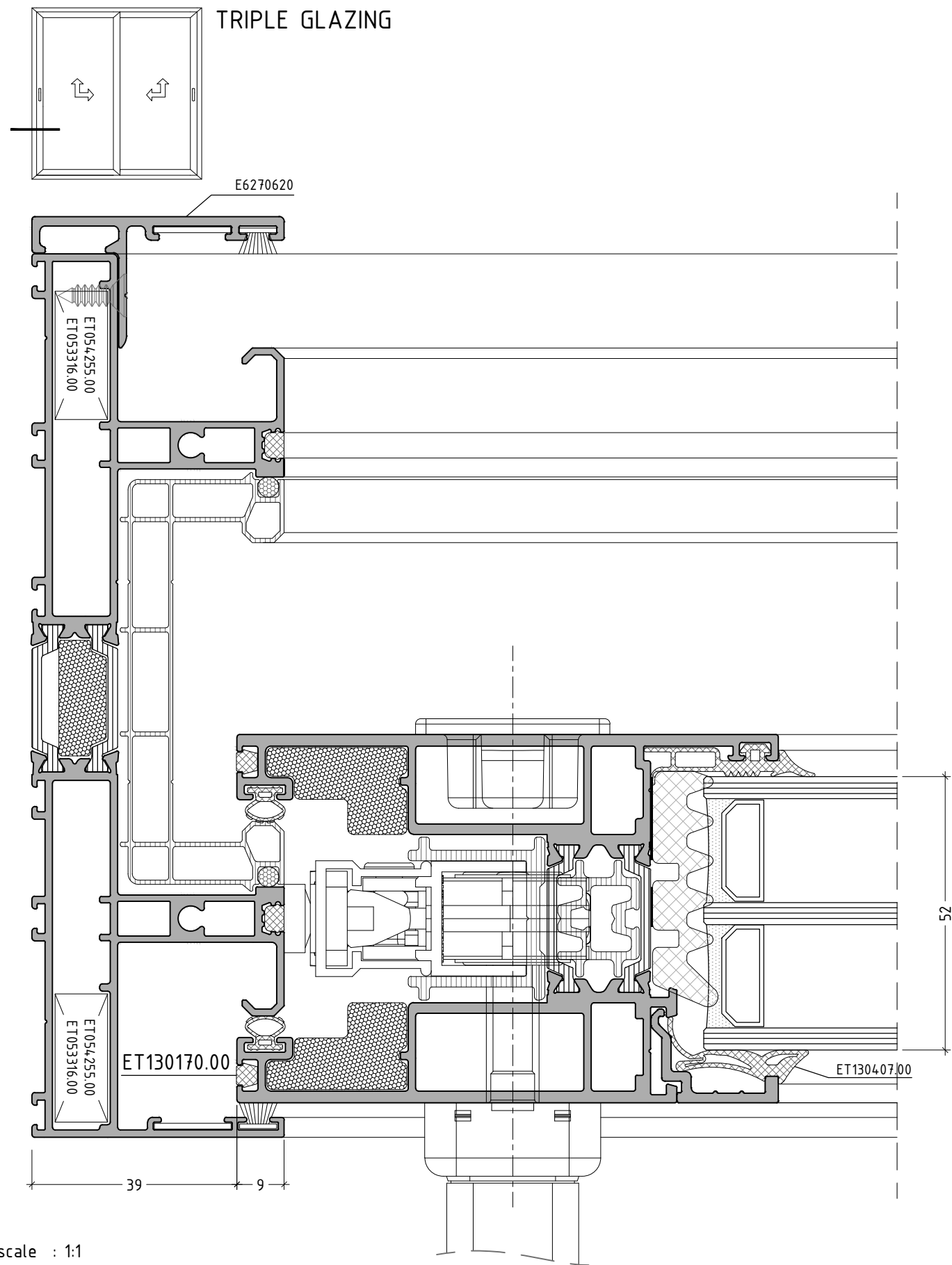

scale : 1:1

sliding system with thermal break

ES70

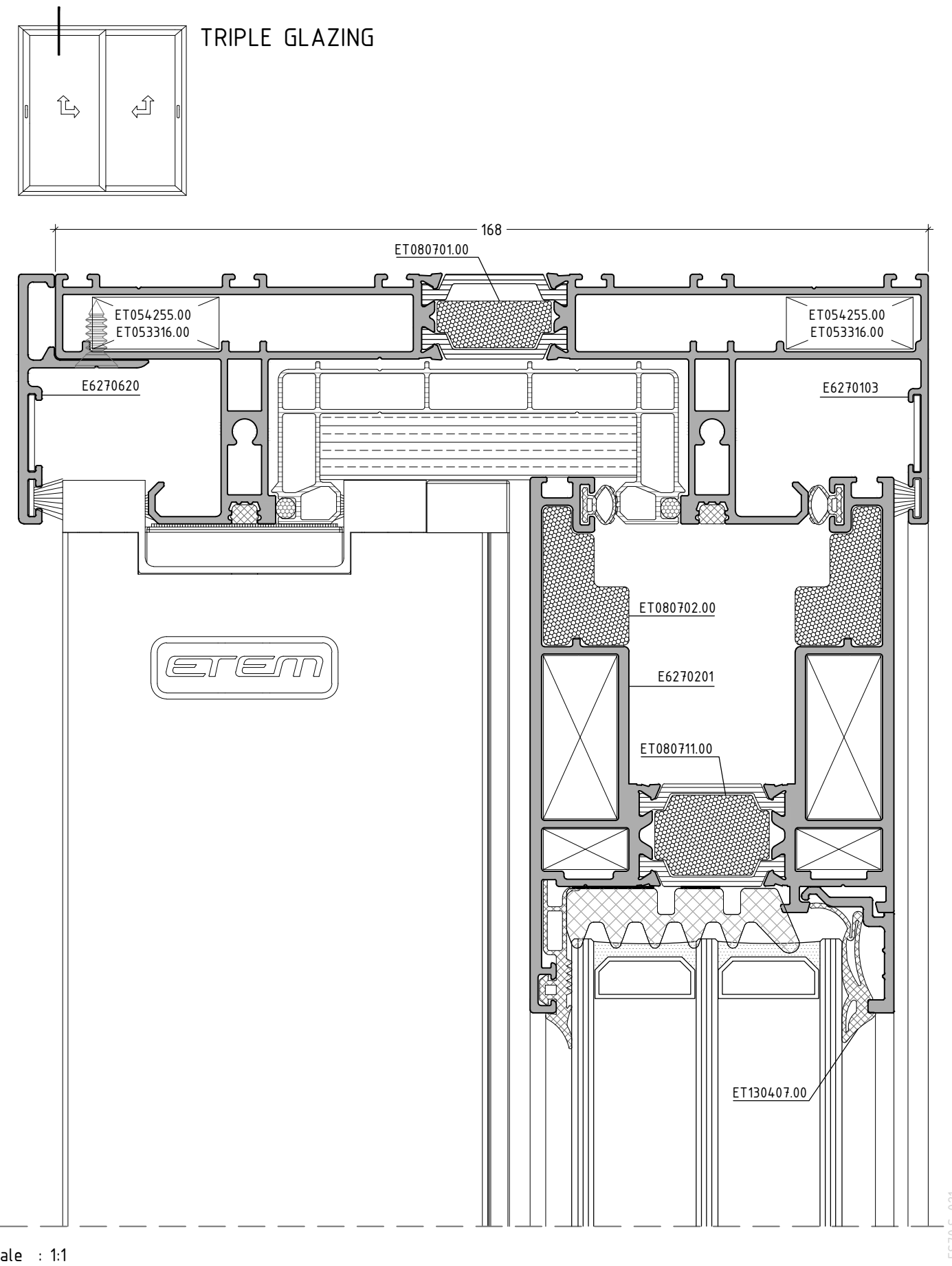

scale : 1:1

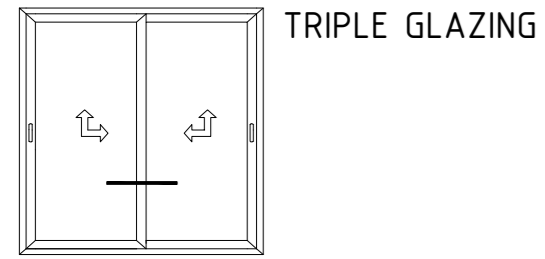

TRIPLE GLAZING

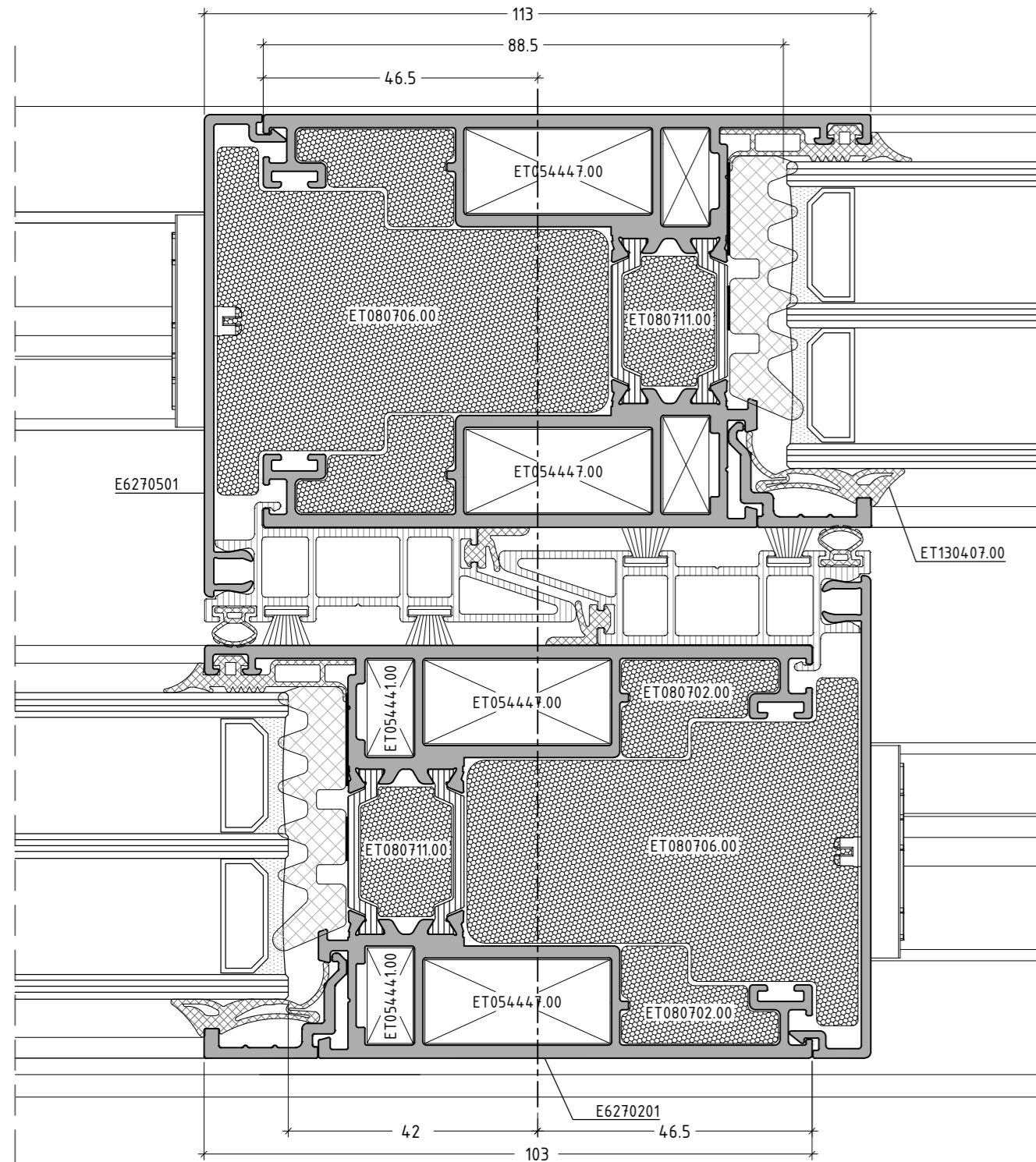



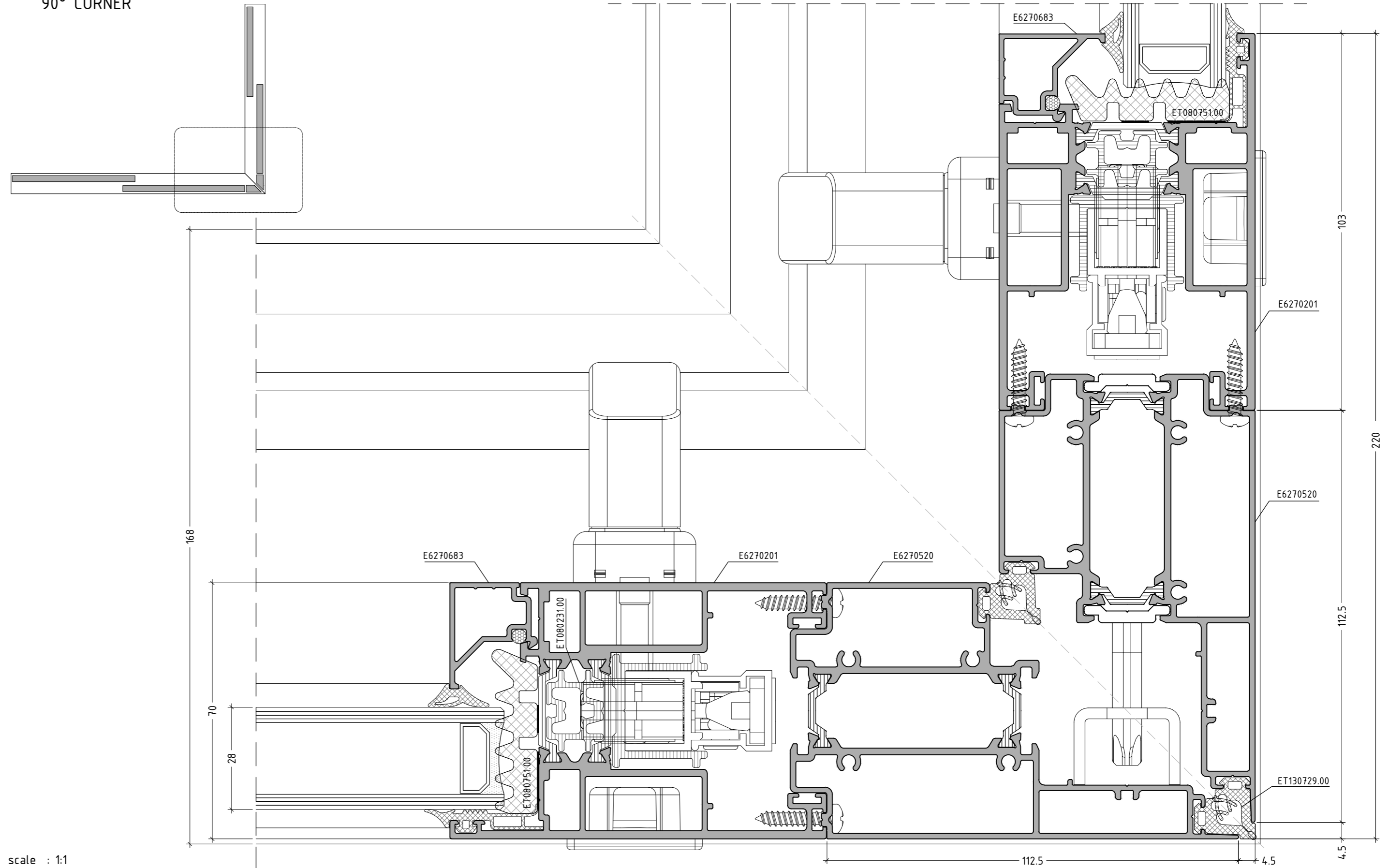

scale : 1:1

90° CORNER

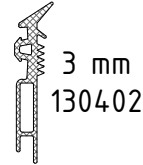

scale : 1:1

GLAZING OPTIONS

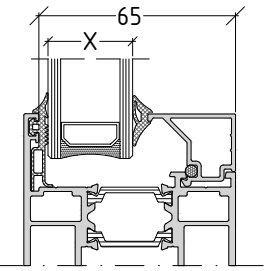
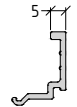
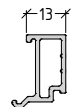
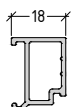
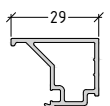
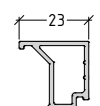
external gaskets	GLAZING OPTIONS				GLAZING BEADS
	INTERNAL GASKETS				
 3 mm 130402	5 mm 130205 	6 mm 130206 	7 mm 130207 	8 mm 130208 	
	X mm				
130402	52	51	50	49	E6270680 
130402	44	43	42	41	E6270681 
130402	39	38	37	36	E6270682 
130402	28	27	26	25	E6270683 
130402	34	33	32	31	E6270684 

Note:
Tolerance in dimension chain ±0.5mm

CUTTING LISTS

DOUBLE LEAF SLIDING WINDOW

ES70.T-01

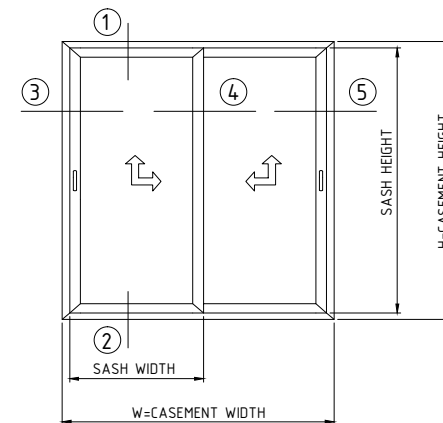

CUTTING LENGTHS

FRAME WIDTH	= W
FRAME HEIGHT	= H
SASH WIDTH	= $\frac{(W+15)}{2}$
SASH HEIGHT	= H - 78
INTERLOCKING HEIGHT	= H - 98

DIMENSIONS IN MILLIMETERS

no scale

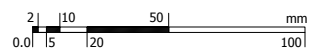
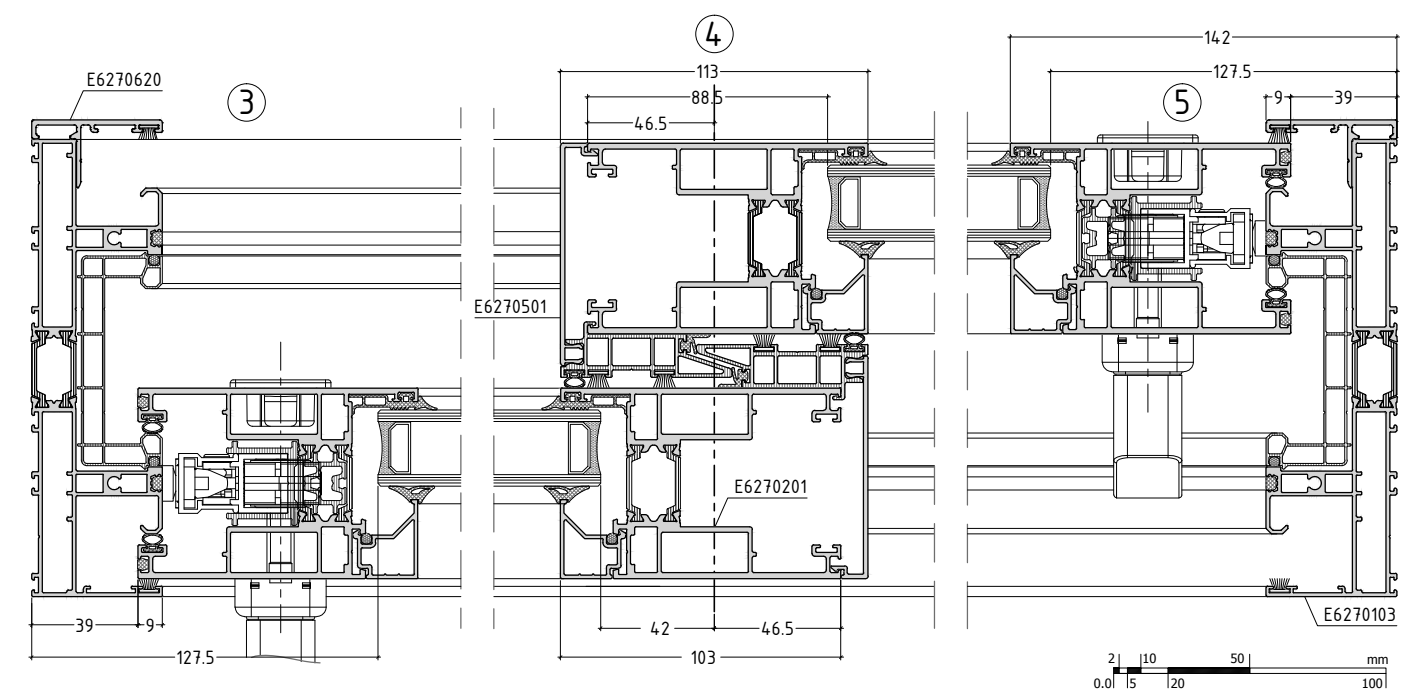
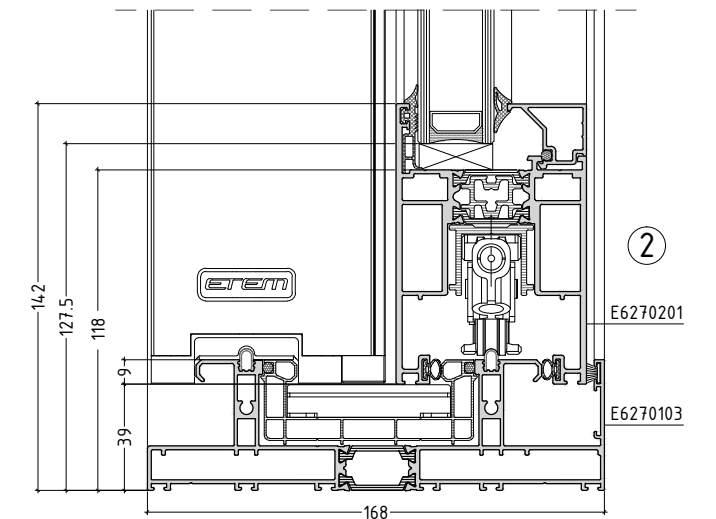
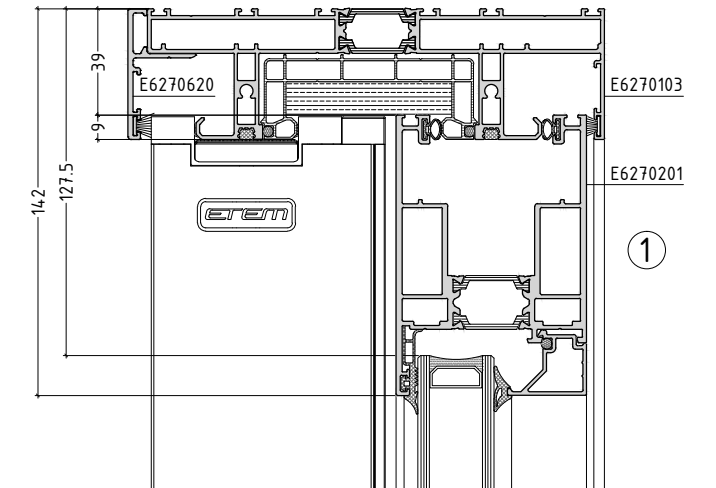

DOUBLE LEAF SLIDING WINDOW WITH SLIM INTERLOCK

ES70.T-02

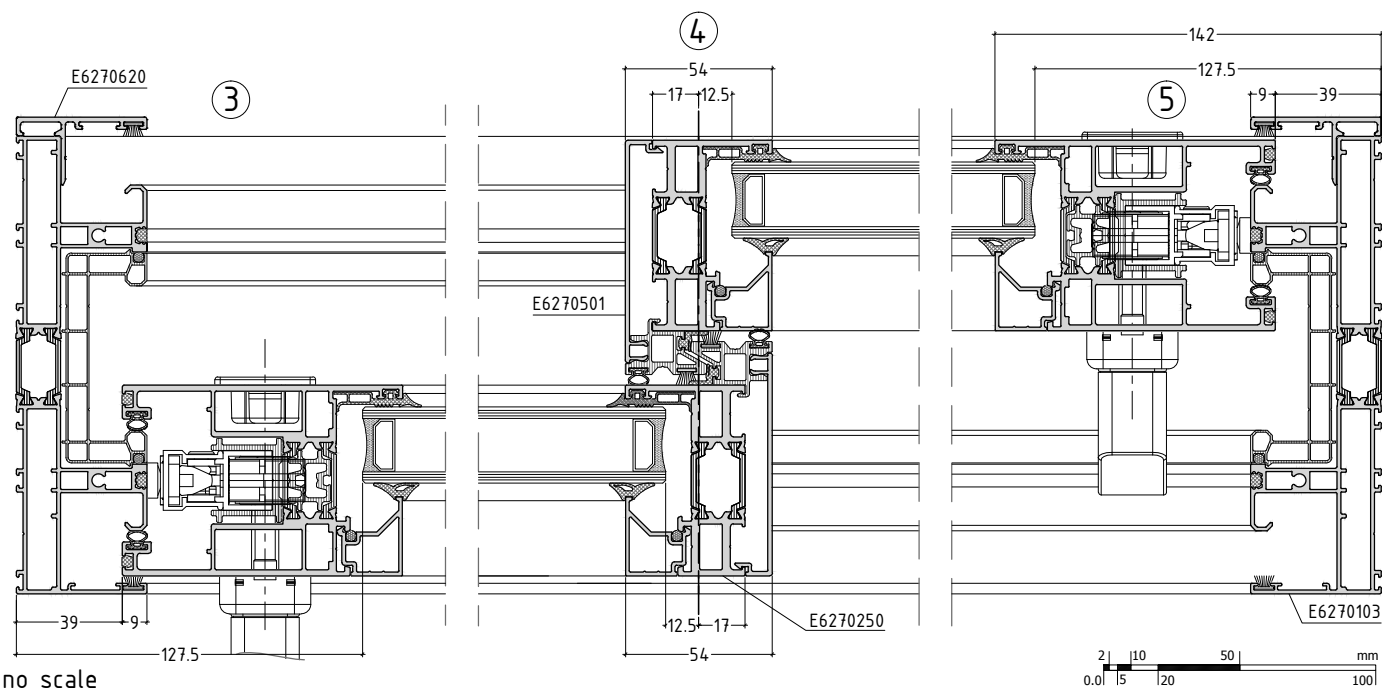
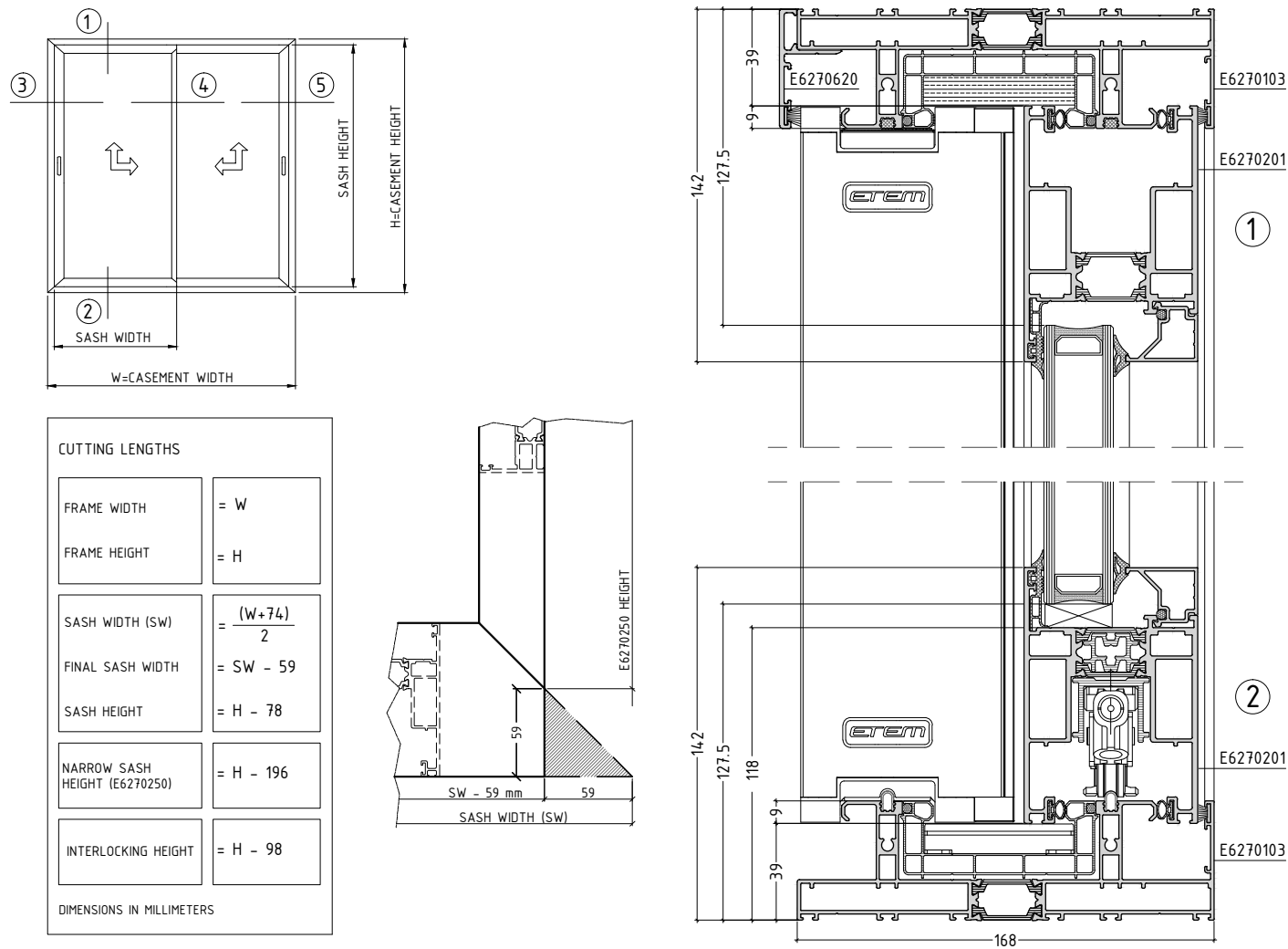

DOUBLE LEAF SLIDING WINDOW WITH FLAT FRAME

ES70.T-03

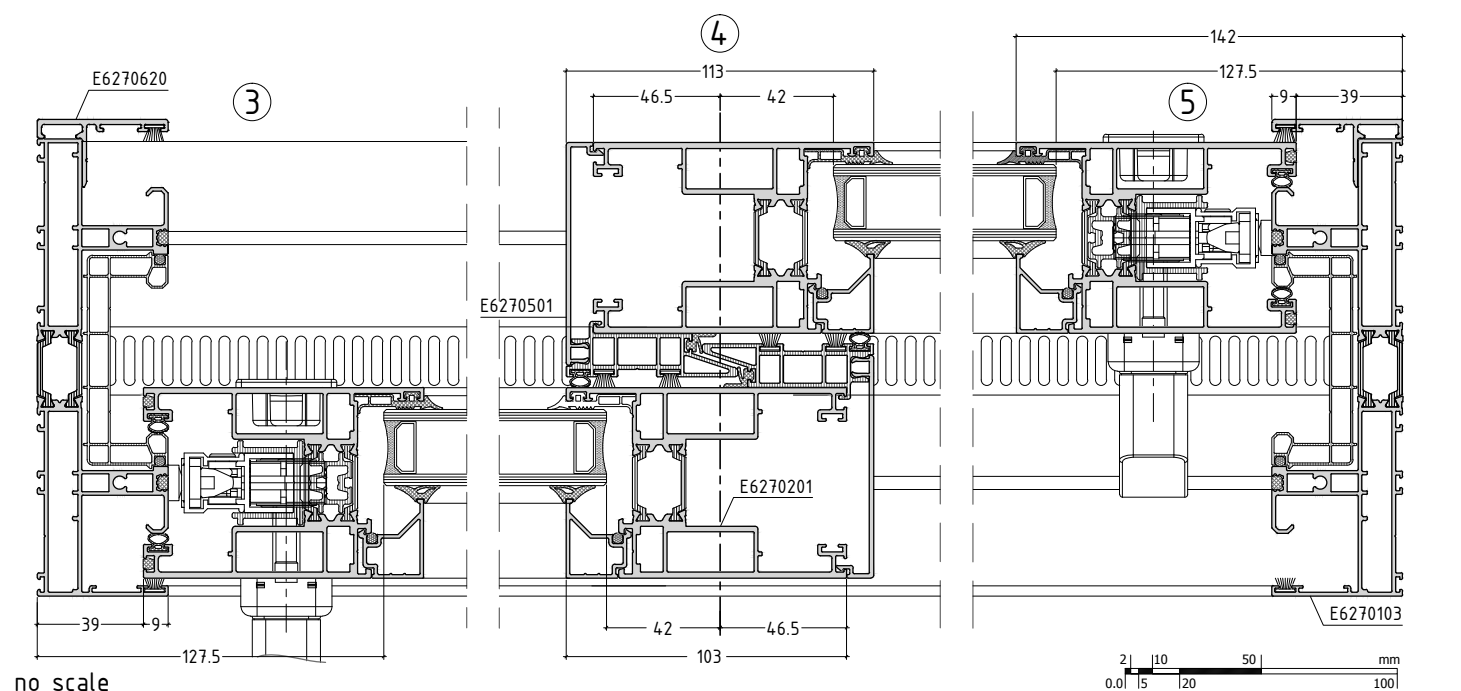
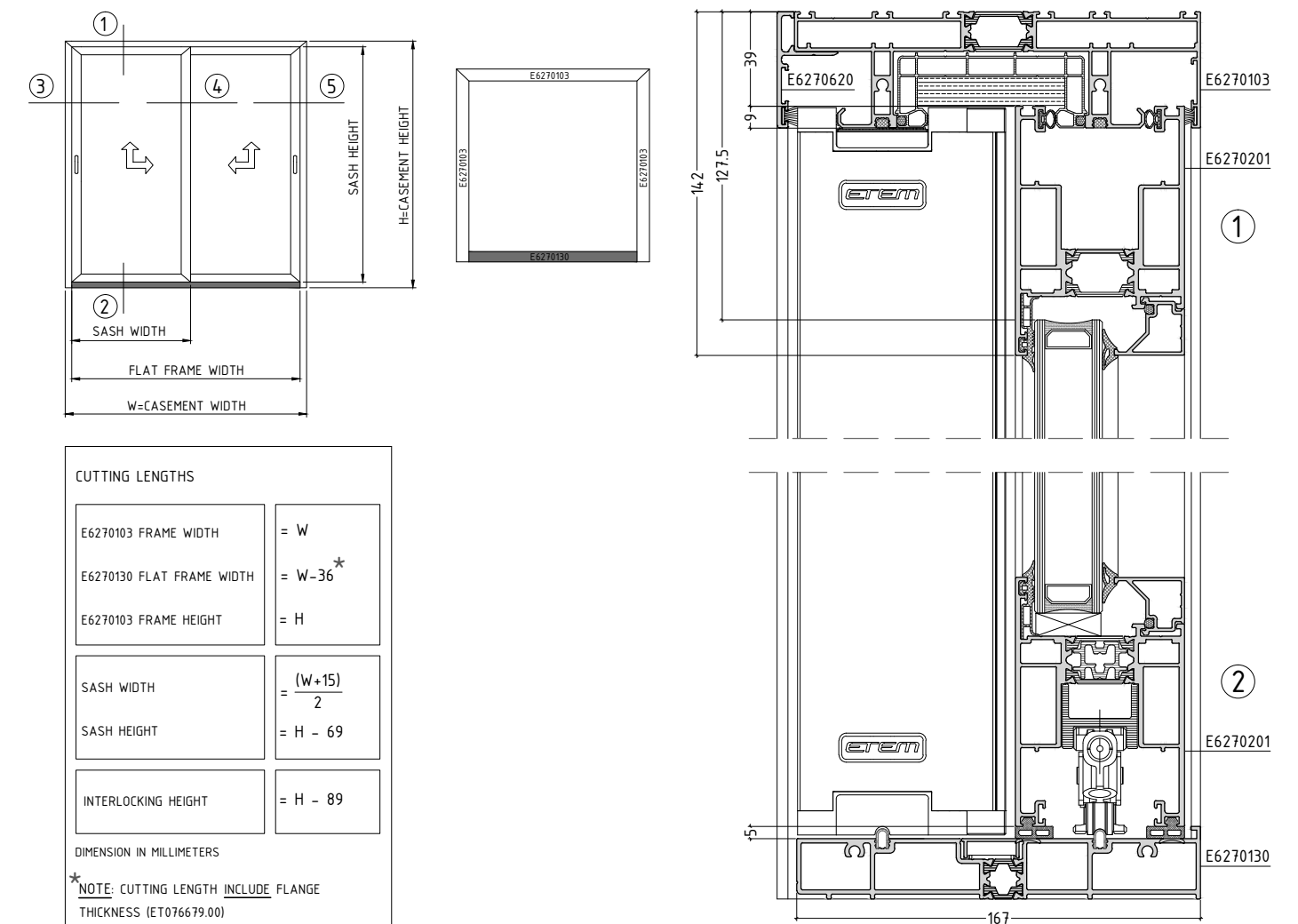

DOUBLE LEAF SLIDING WINDOW WITH FLYSCREEN

ES70.T-04
Vertical sect.

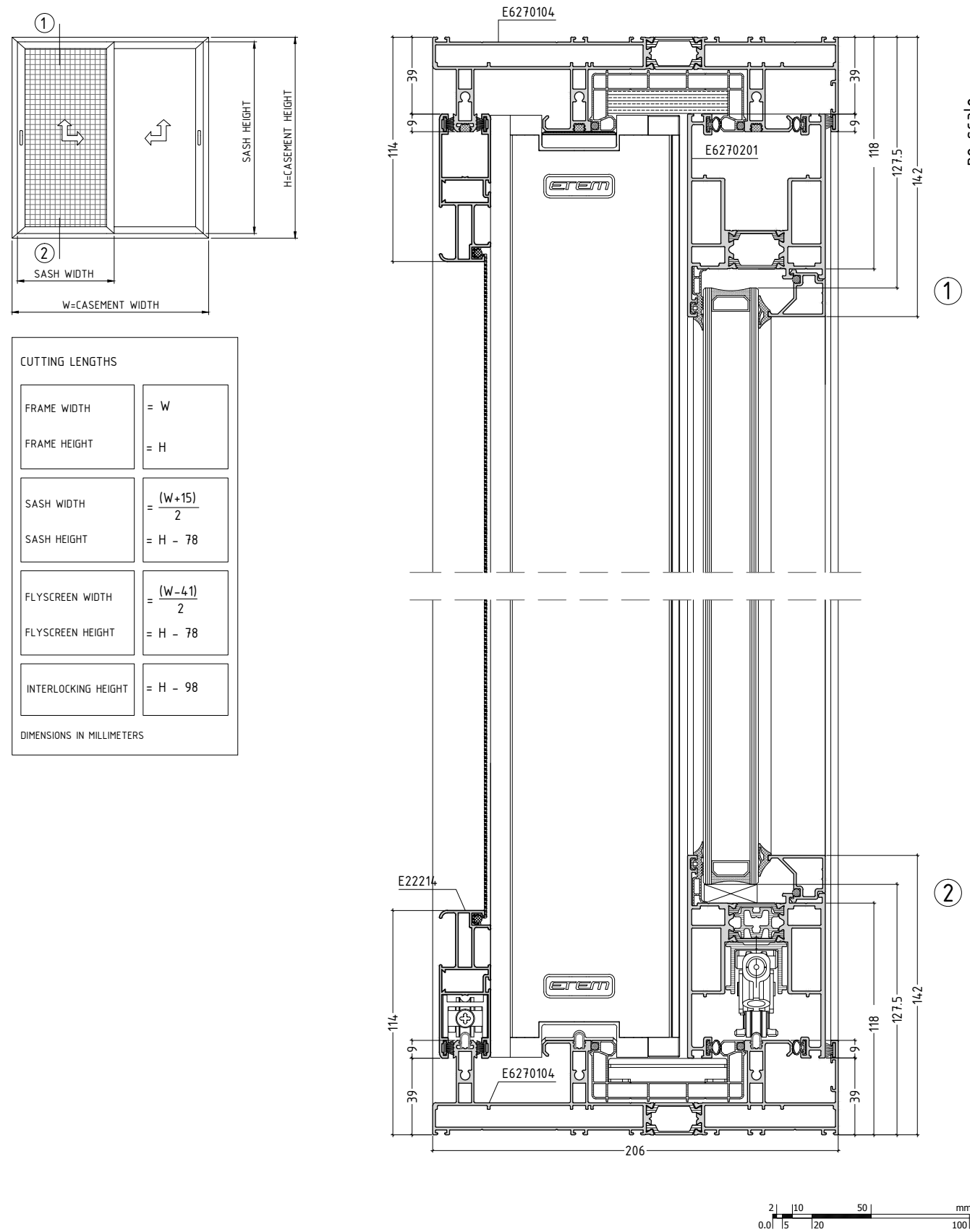

DOUBLE LEAF SLIDING WINDOW WITH FLYSCREEN

ES70.T-04
Horizontal sect.

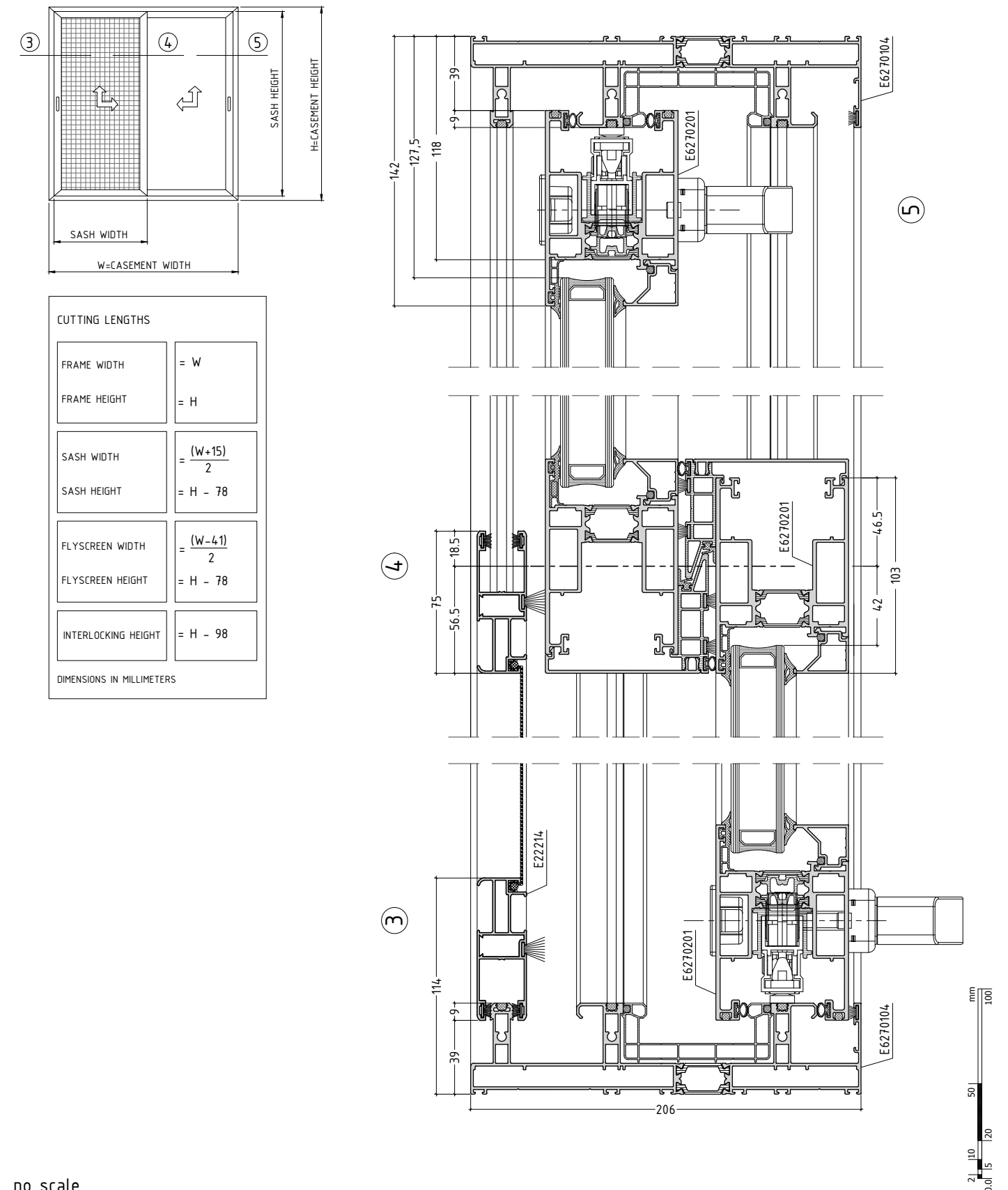

DOUBLE LEAF SLIDING WINDOW WITH FLY SCREEN - FLAT FRAME

ES70.T-05
Vertical sect.

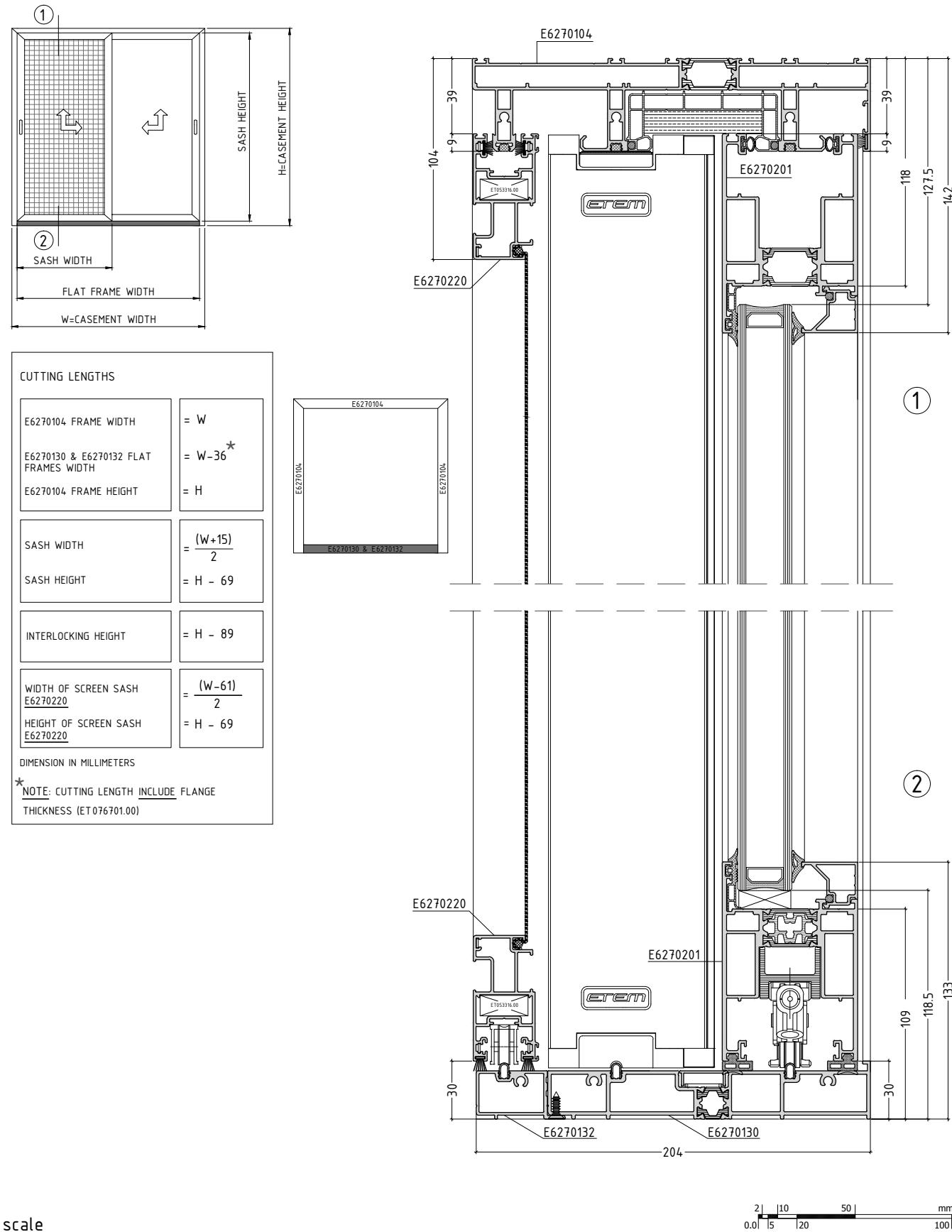

no scale

DOUBLE LEAF SLIDING WINDOW WITH FLY SCREEN - FLAT FRAME

ES70.T-05
Horizontal sect.

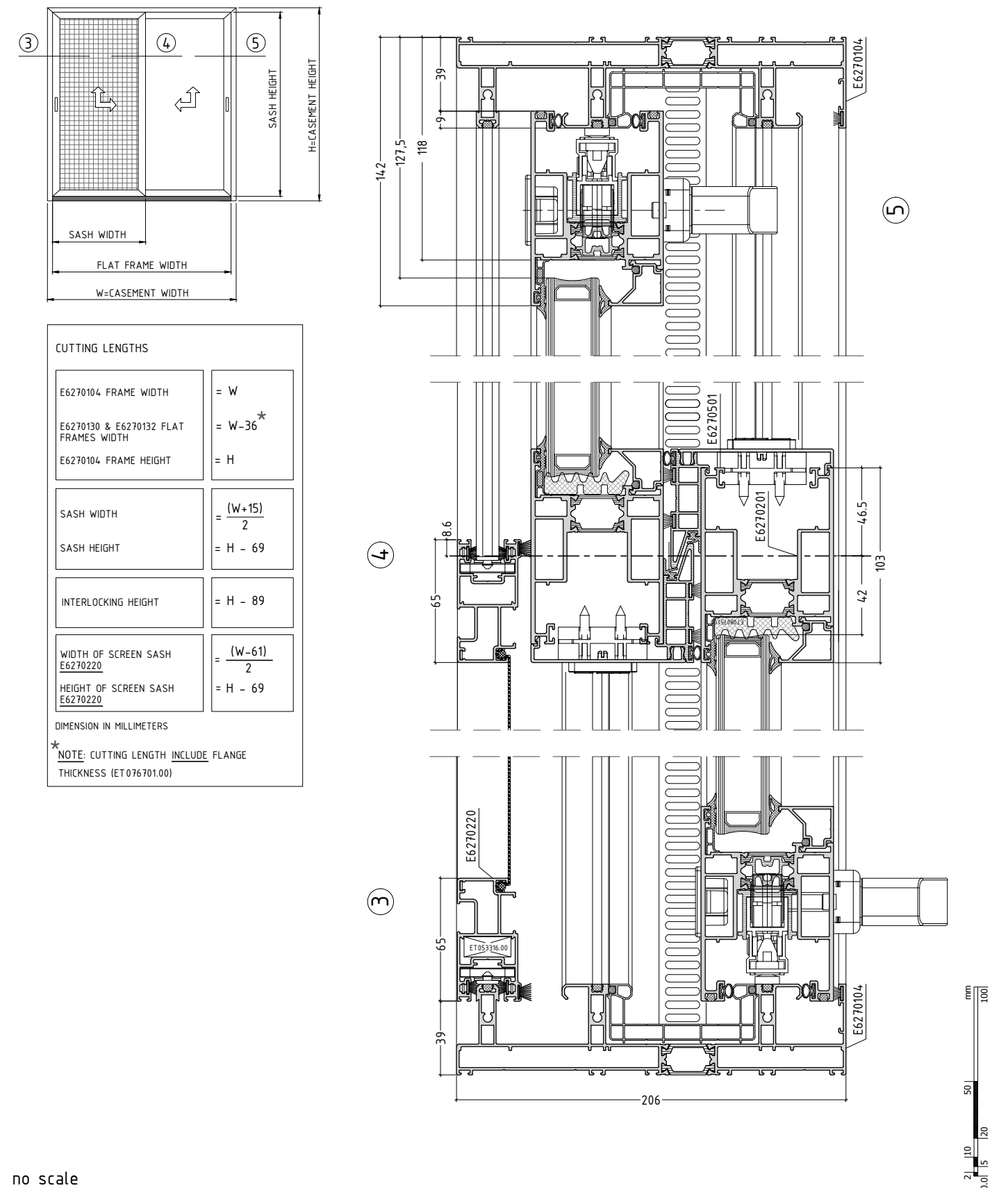

no scale

DOUBLE LEAF SLIDING WINDOW WITH FLY SCREEN - FLAT FRAME

ES70.T-06
Vertical sect.

SLIM INTERLOCK

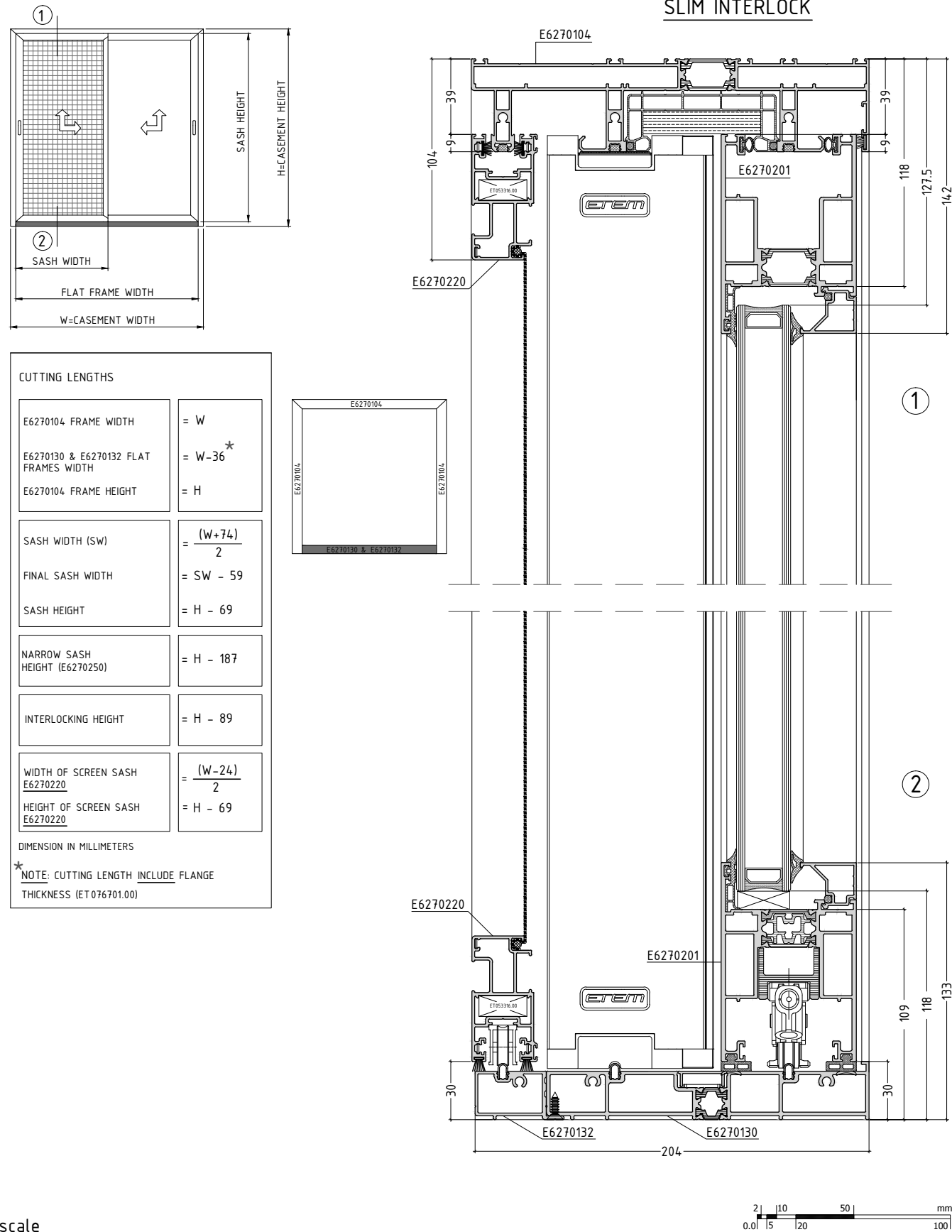

no scale

DOUBLE LEAF SLIDING WINDOW WITH FLY SCREEN - FLAT FRAME

ES70.T-06
Horizontal sect.

SLIM INTERLOCK

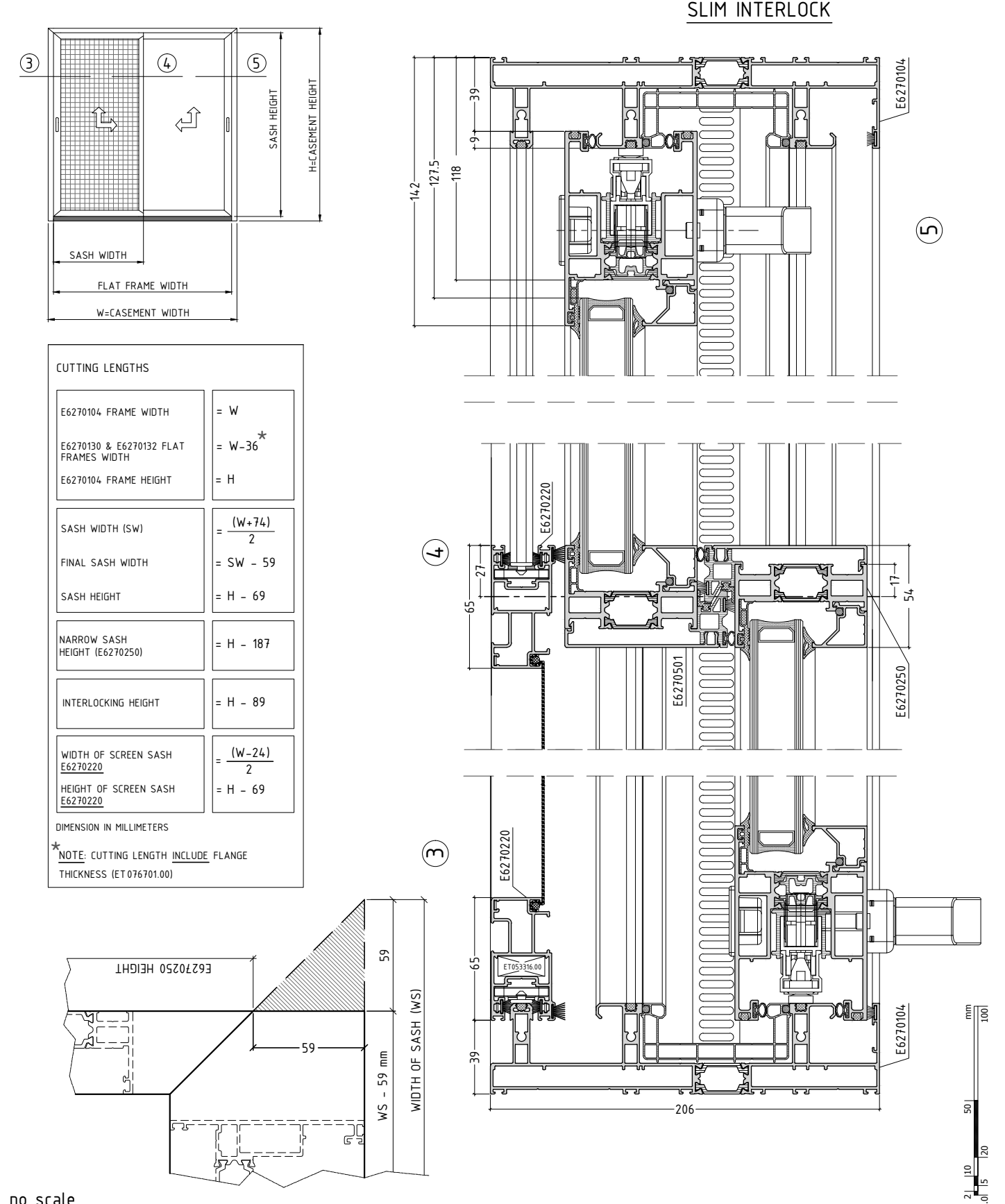

no scale

TRIPLE LEAF SLIDING WINDOW

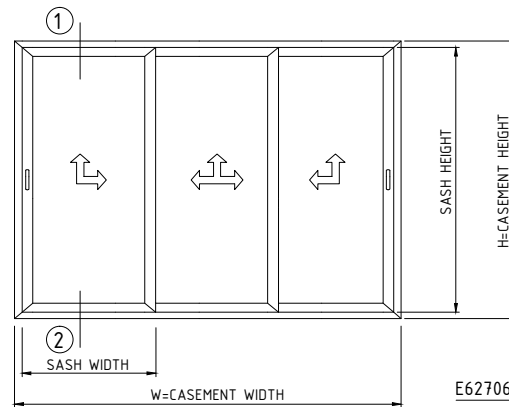

CUTTING LENGTHS

FRAME WIDTH	= W
FRAME HEIGHT	= H
SASH WIDTH	= $\frac{(W+108)}{3}$
SASH HEIGHT	= H - 78
INTERLOCKING HEIGHT	= H - 98

DIMENSIONS IN MILLIMETERS

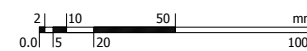
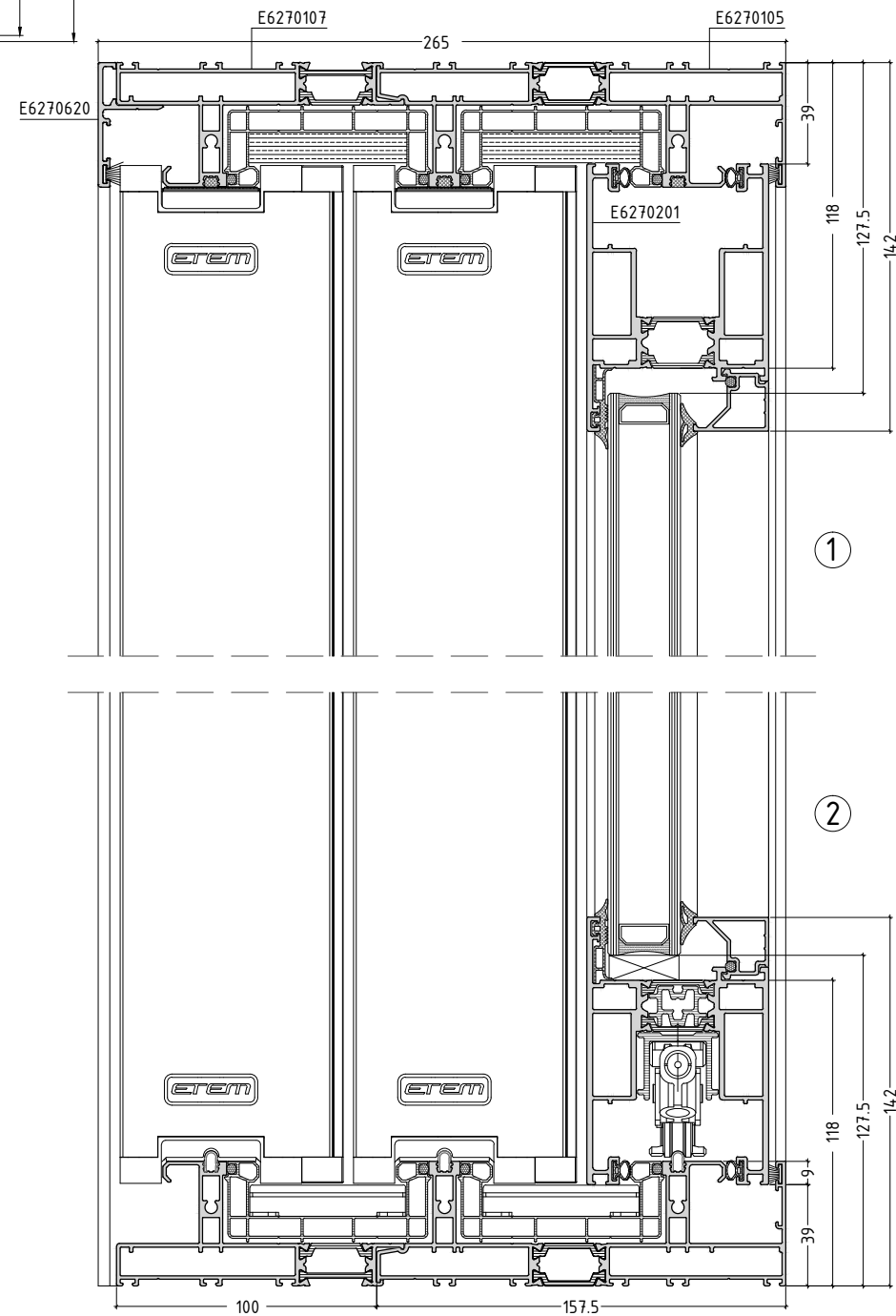

no scale

TRIPLE LEAF SLIDING WINDOW

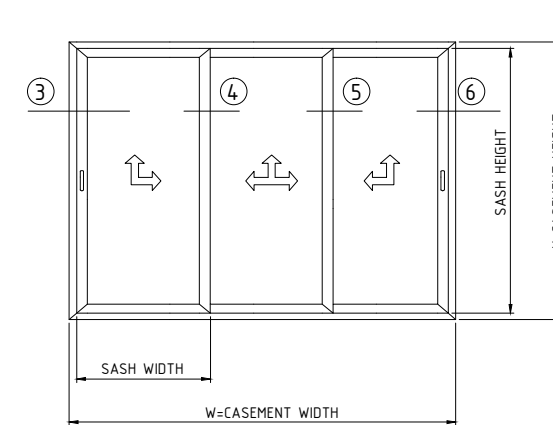

CUTTING LENGTHS

FRAME WIDTH	= W
FRAME HEIGHT	= H
SASH WIDTH	= $\frac{(W+108)}{3}$
SASH HEIGHT	= H - 78
INTERLOCKING HEIGHT	= H - 98

DIMENSIONS IN MILLIMETERS

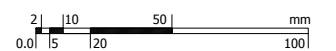
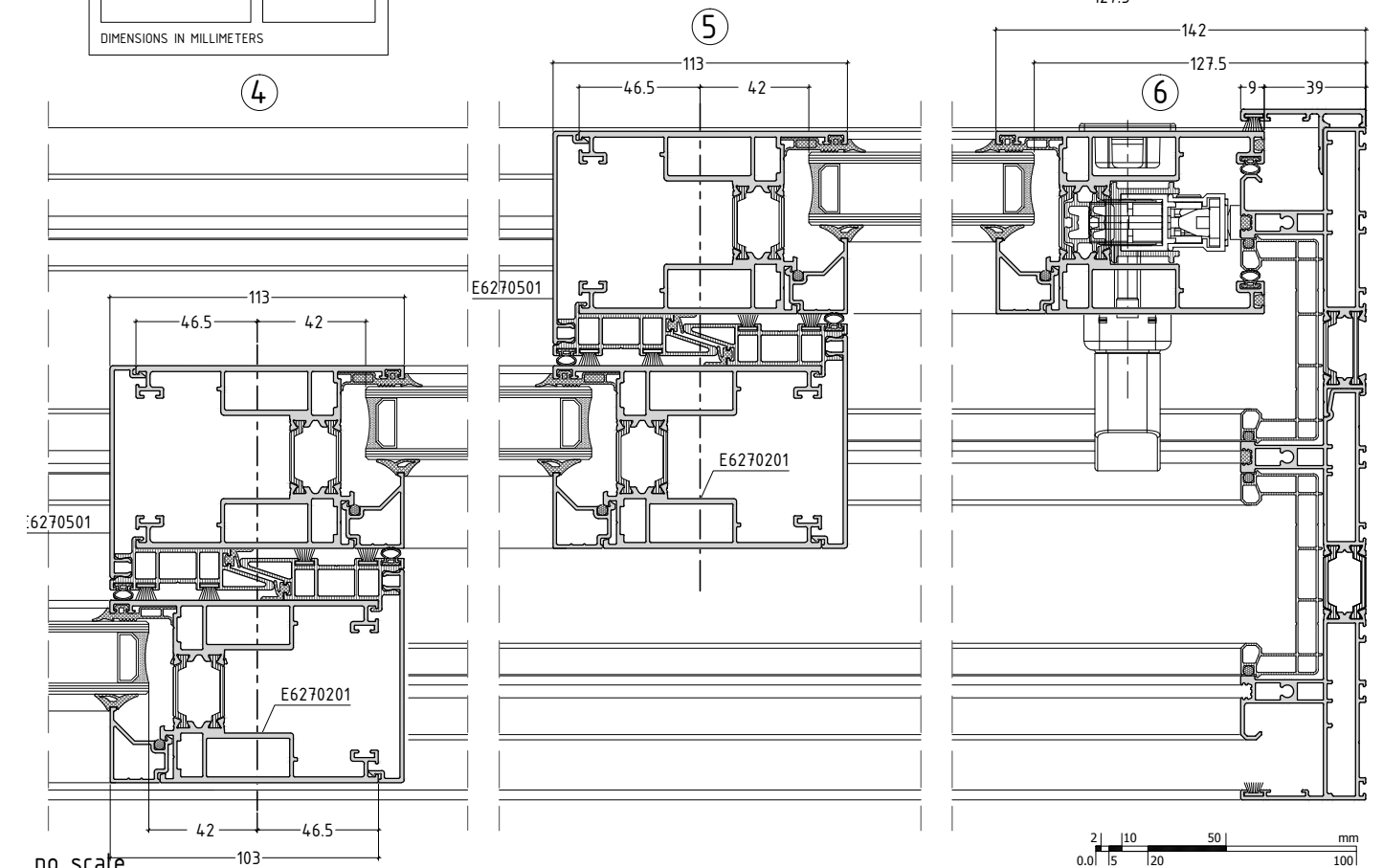

no scale

QUADRUPLE LEAF SLIDING WINDOW

ES70.T-08
Vertical sect.

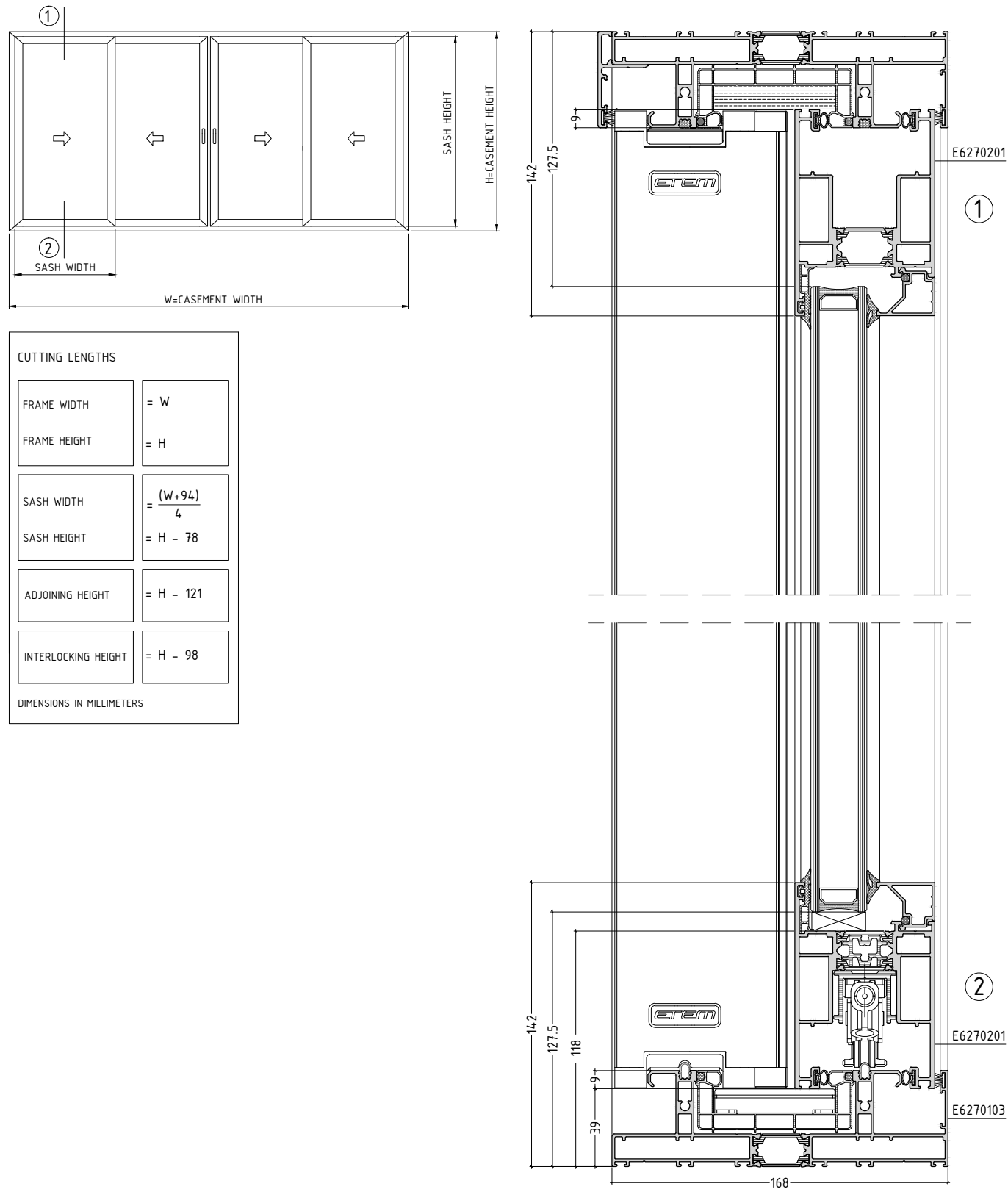

no scale

QUADRUPLE LEAF SLIDING WINDOW

ES70.T-08
Horizontal sect.

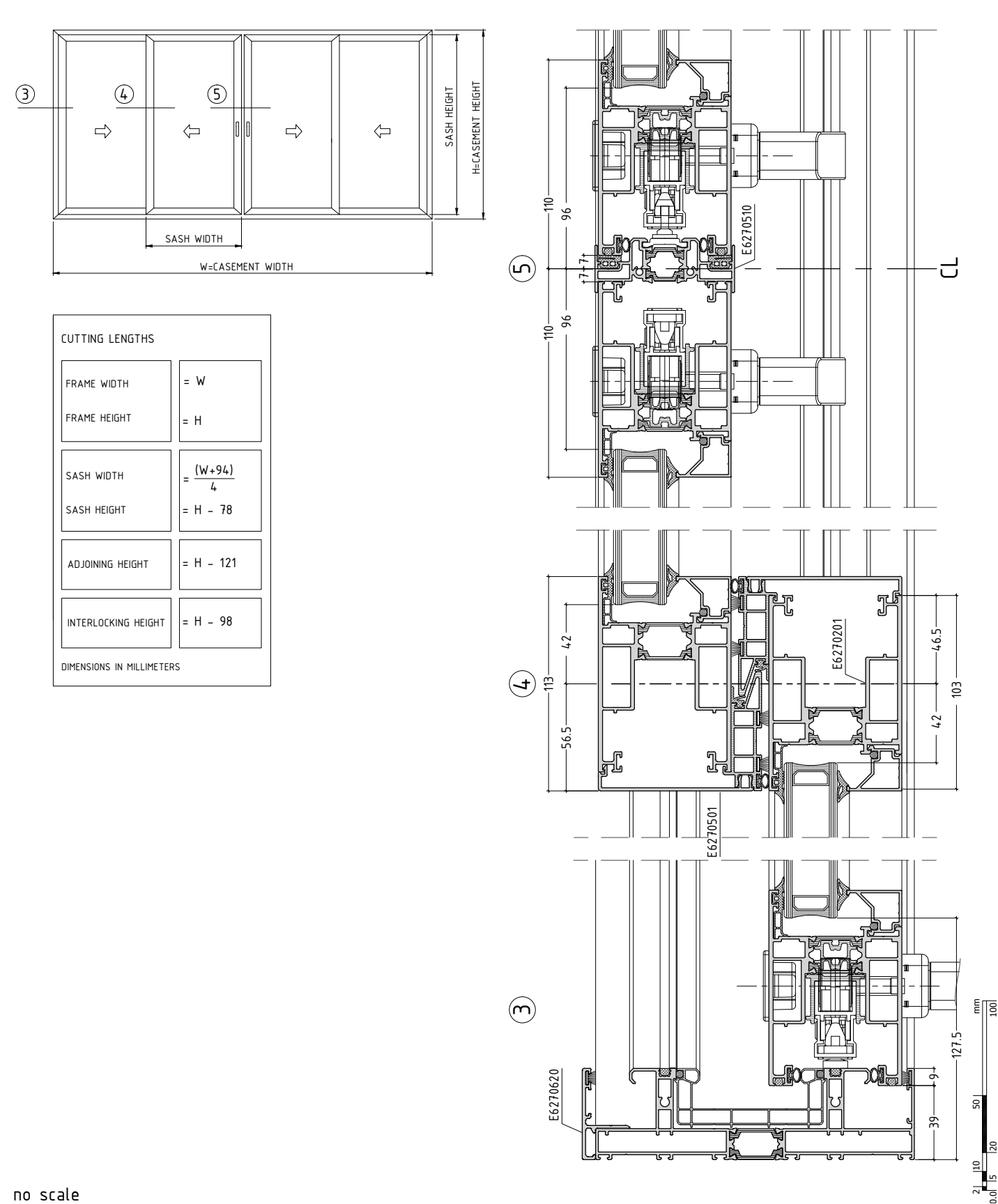

no scale

sliding system with thermal break

ES70

HOTEL TYPE (SLIM INTERLOCK)
LIFTING & SLIDING WINDOW - FIXED

ES70.T-09

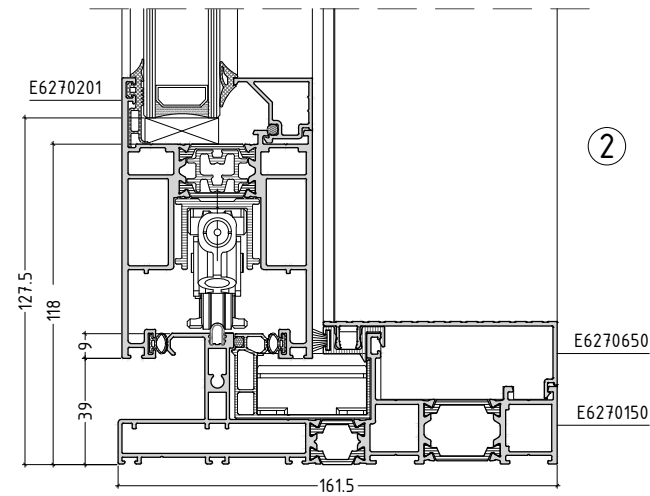
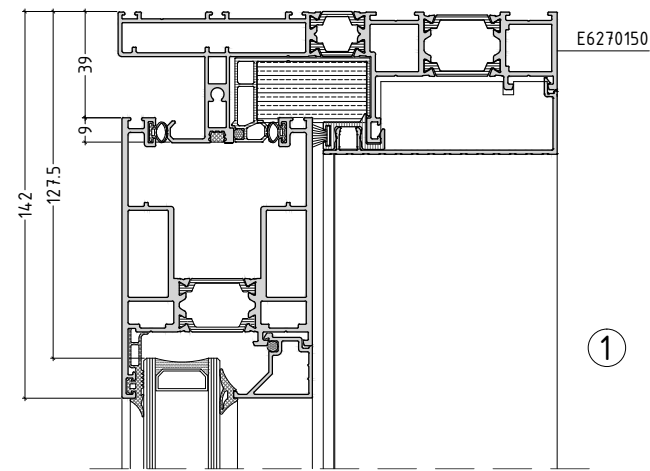
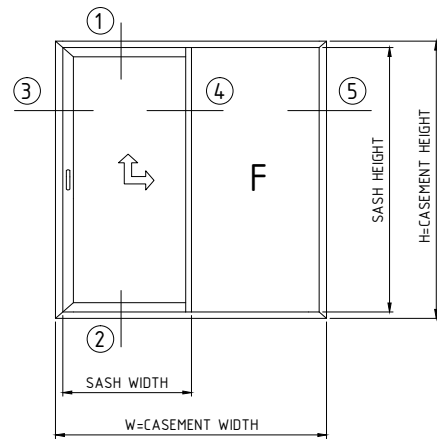

CUTTING LENGTHS

FRAME WIDTH	= W
FRAME HEIGHT	= H
SASH WIDTH (SW)	$= \frac{W}{2} + 75$
FINAL SASH WIDTH	= SW - 59
SASH HEIGHT (E6270201)	= H - 78
NARROW SASH HEIGHT (E6270250) (FOR SLIDING PART)	= H - 196
NARROW SASH HEIGHT (E6270250) (AS MULLION FOR FIXED)	= H - 48
6270501 INTERLOCKING HEIGHT	= H - 98
6270501 (FOR FIXED) INTERLOCKING HEIGHT	= H - 48

DIMENSIONS IN MILLIMETERS

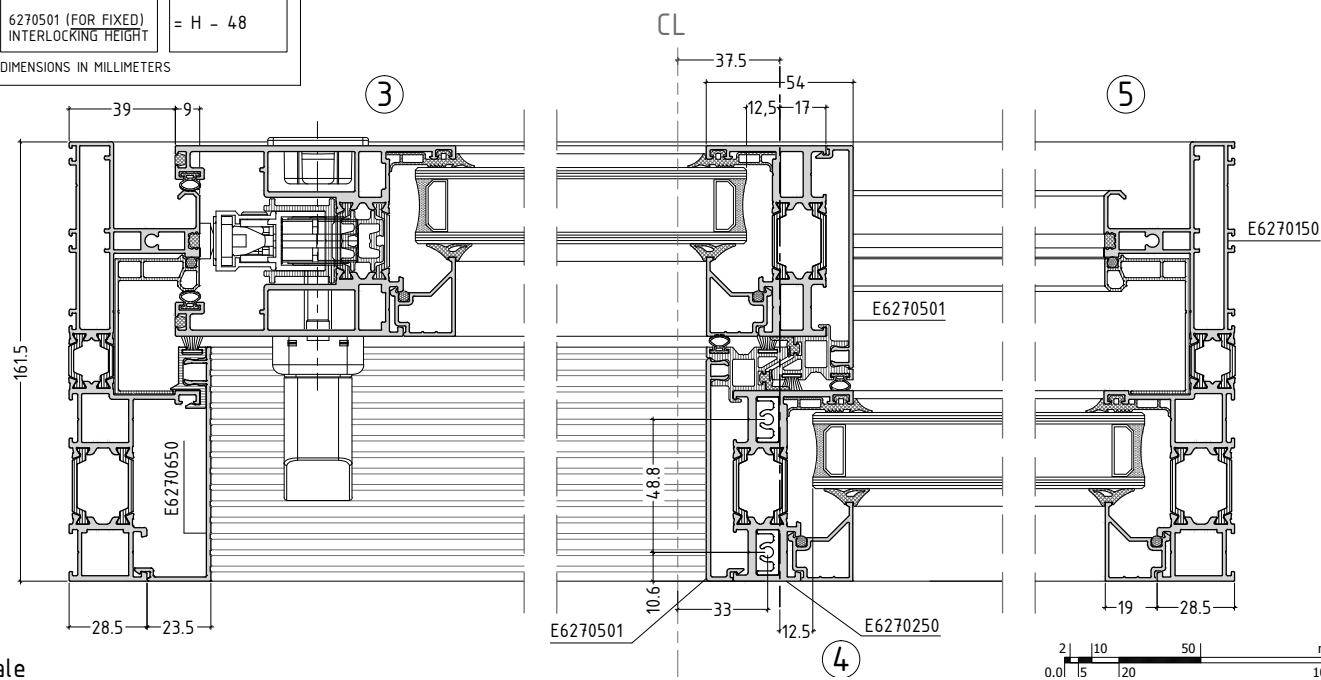
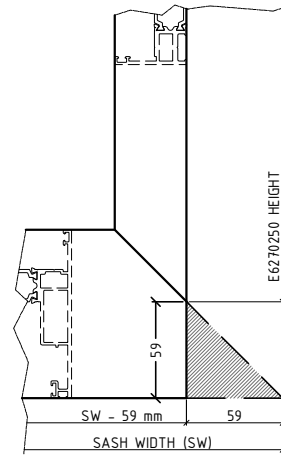

no scale

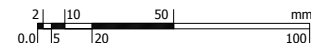

sliding system with thermal break

ES70

HOTEL TYPE (CLASSIC INTERLOCK)
LIFTING & SLIDING WINDOW - FIXED

ES70.T-010

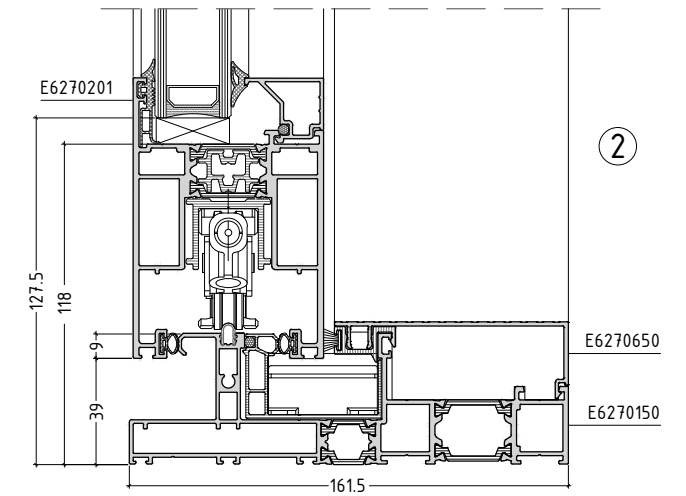
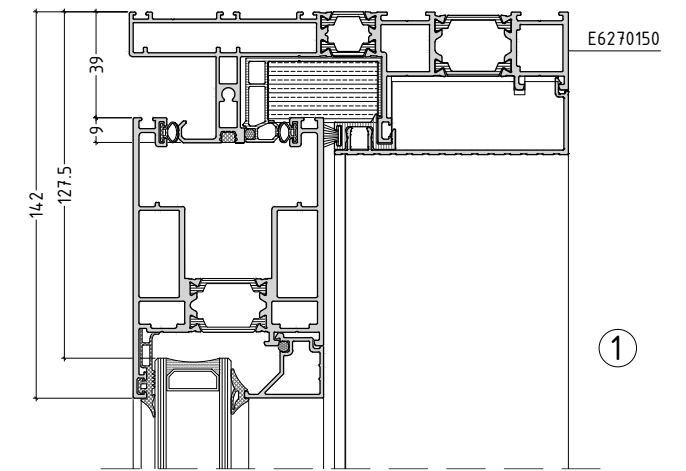
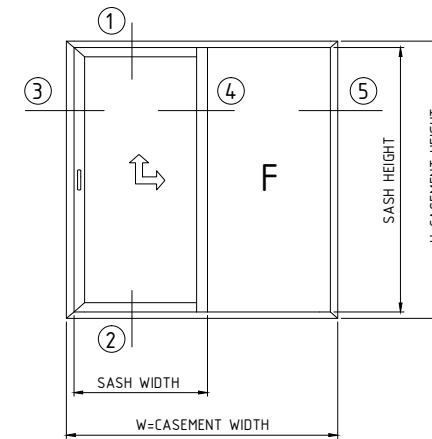

CUTTING LENGTHS

FRAME WIDTH	= W
FRAME HEIGHT	= H
SASH WIDTH	$= \frac{W}{2} + 45$
SASH HEIGHT	= H - 78
6270350 MULLION HEIGHT	= H - 48
6270501 INTERLOCKING HEIGHT	= H - 98
6270501 (FOR FIXED) INTERLOCKING HEIGHT	= H - 48

DIMENSIONS IN MILLIMETERS

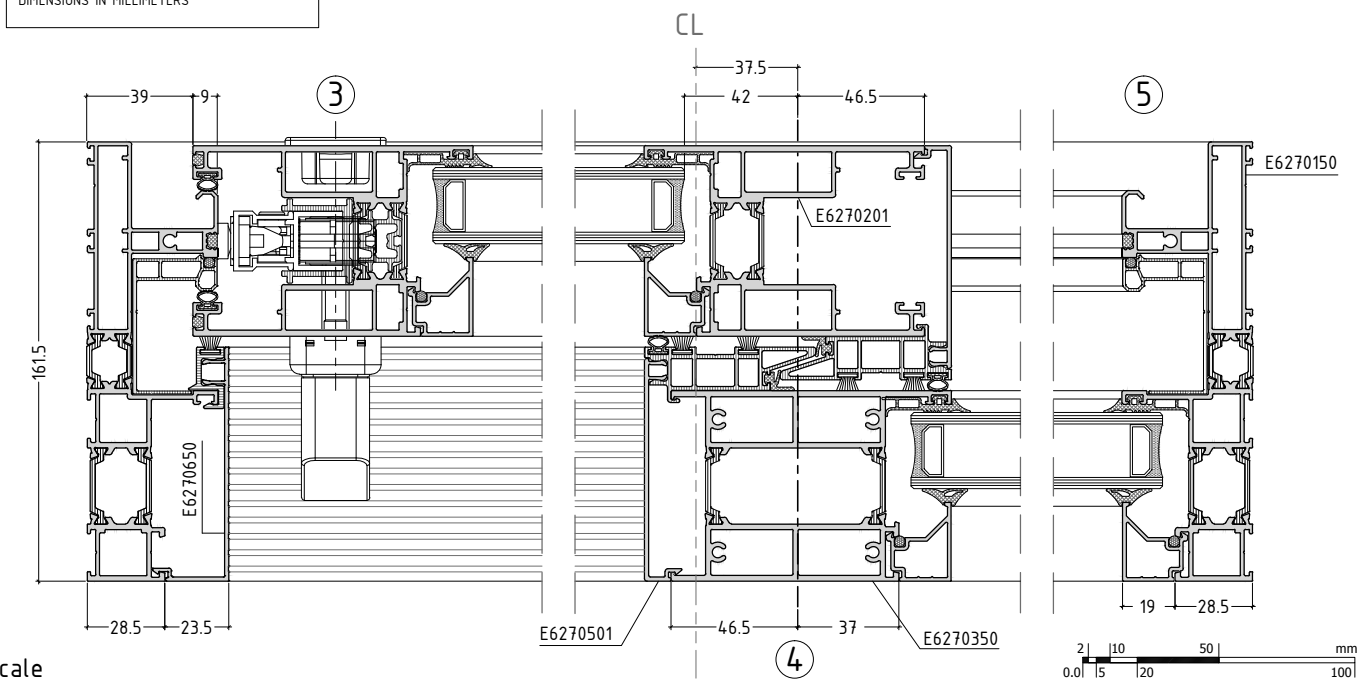

no scale

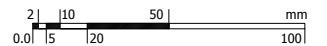

HOTEL TYPE (CLASSIC INTERLOCK)
FIXED - MEETING DOUBLE SASH LIFTING & SLIDING WINDOW - FIXED

ES70.T-011

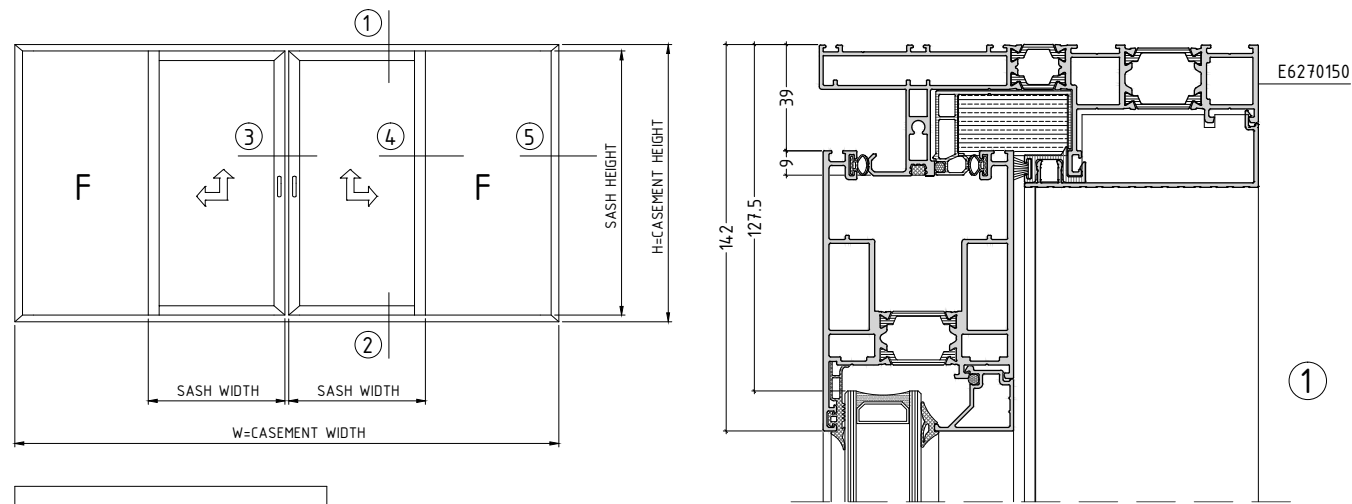

CUTTING LENGTHS

FRAME WIDTH	= W
FRAME HEIGHT	= H
SASH WIDTH	= $\frac{W}{4} + 63$
SASH HEIGHT	= H - 78
E6270350 MULLION HEIGHT	= H - 48
E6270501 INTERLOCKING HEIGHT	= H - 98
E6270501 (FOR FIXED) INTERLOCKING HEIGHT	= H - 48
E6270510 ADJOINING HEIGHT	= H - 121

DIMENSIONS IN MILLIMETERS

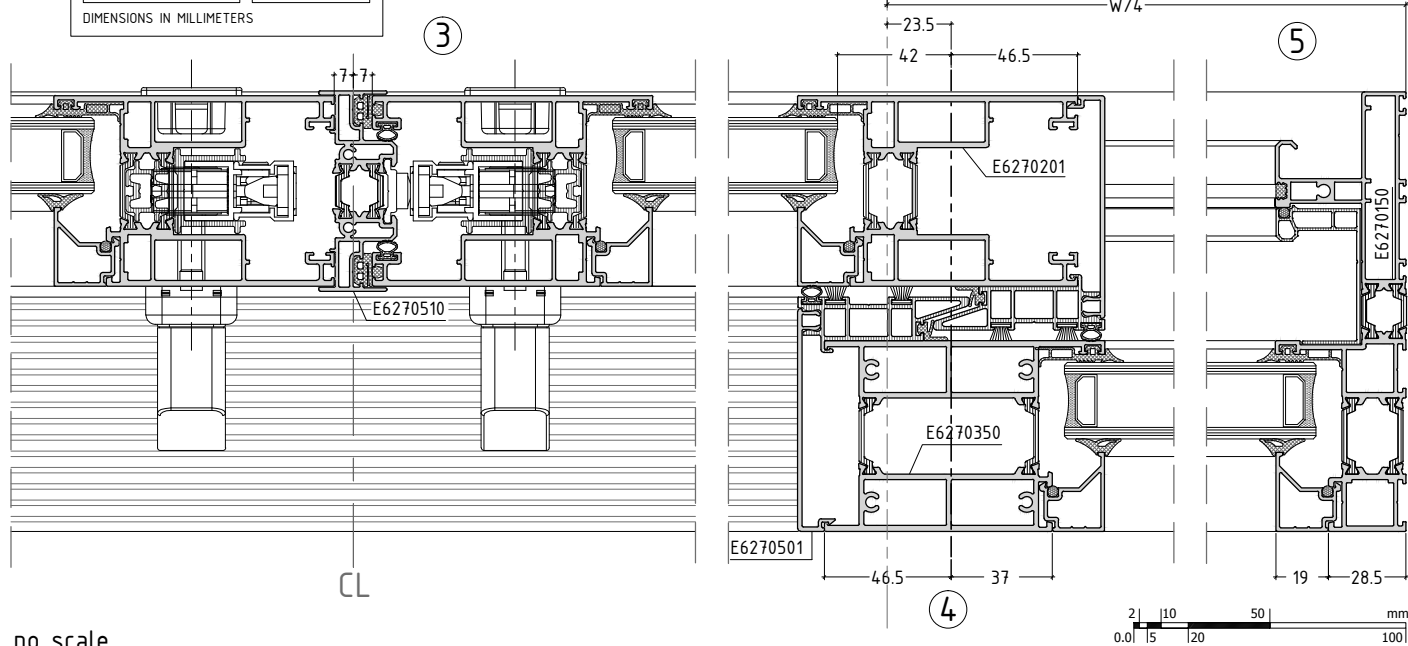

no scale

DOUBLE LEAF LIFT & SLIDE WITH 90° CORNER PROFILE

ES70.T-012

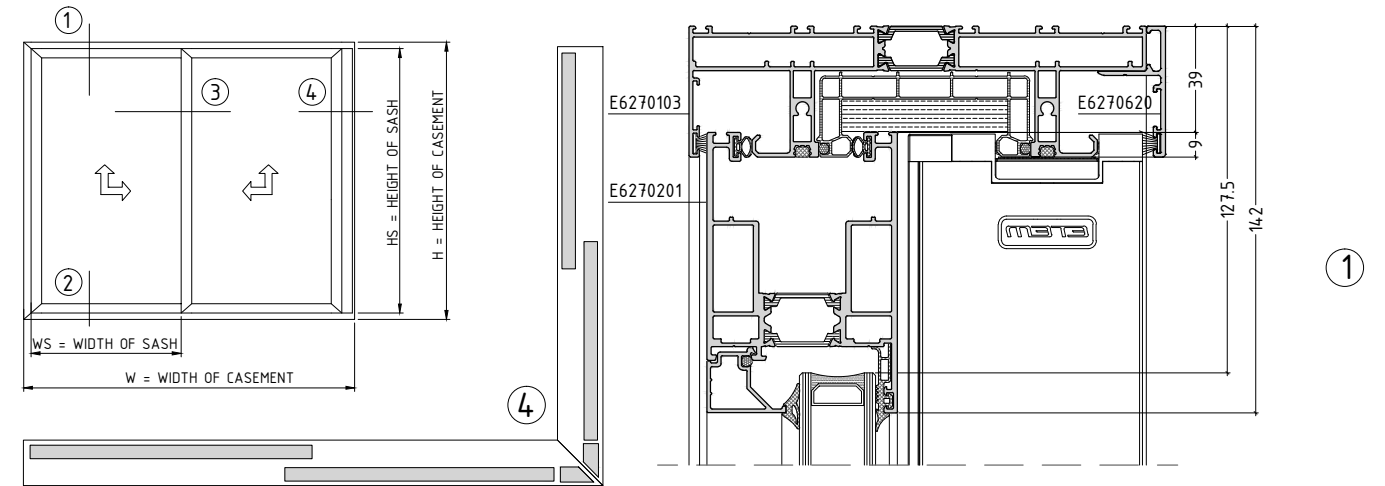

CUTTING LENGTHS

WIDTH OF RAIL E6270103	= W
HEIGHT OF FRAME E6270103	= H
WS (WIDTH OF SASH)	= $\frac{W - 65}{2}$
HS (HEIGHT OF SASH)	= H - 78
HEIGHT OF SUPL. E6070501	= H - 98
HEIGHT OF E6270520	= H - 88

DIMENSION IN MILLIMETERS

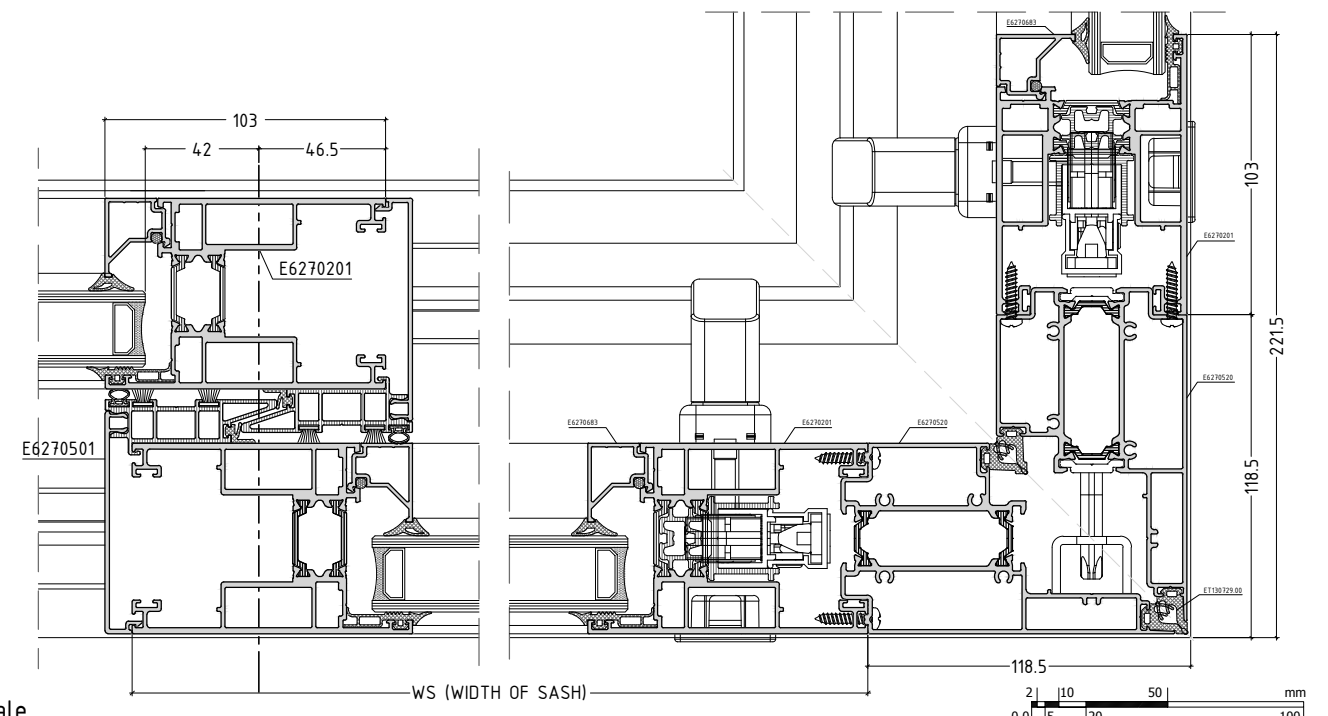
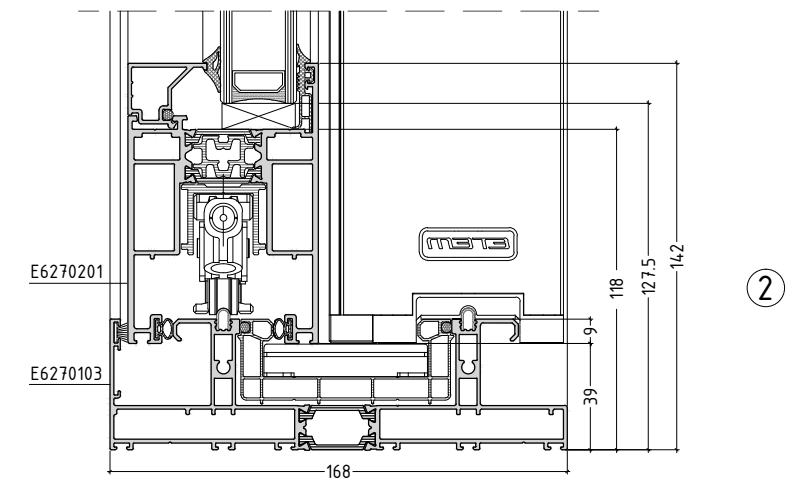

no scale

MACHININGS

MACHININGS / PROCESSING

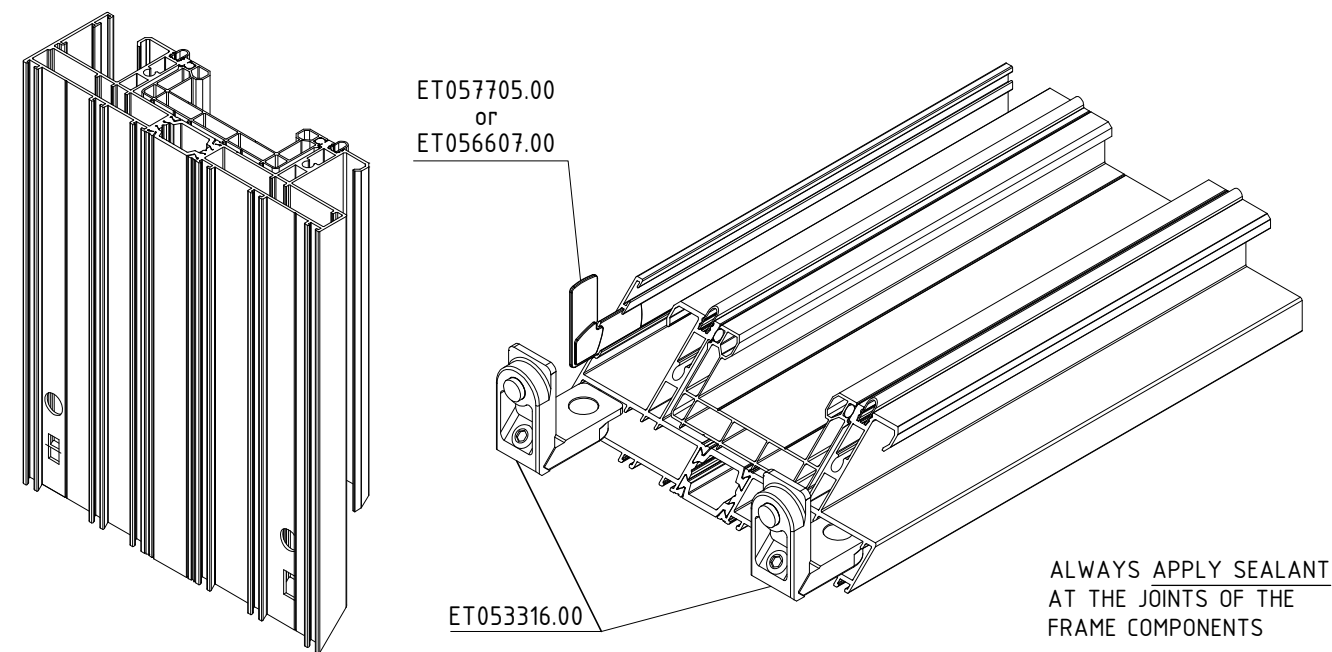
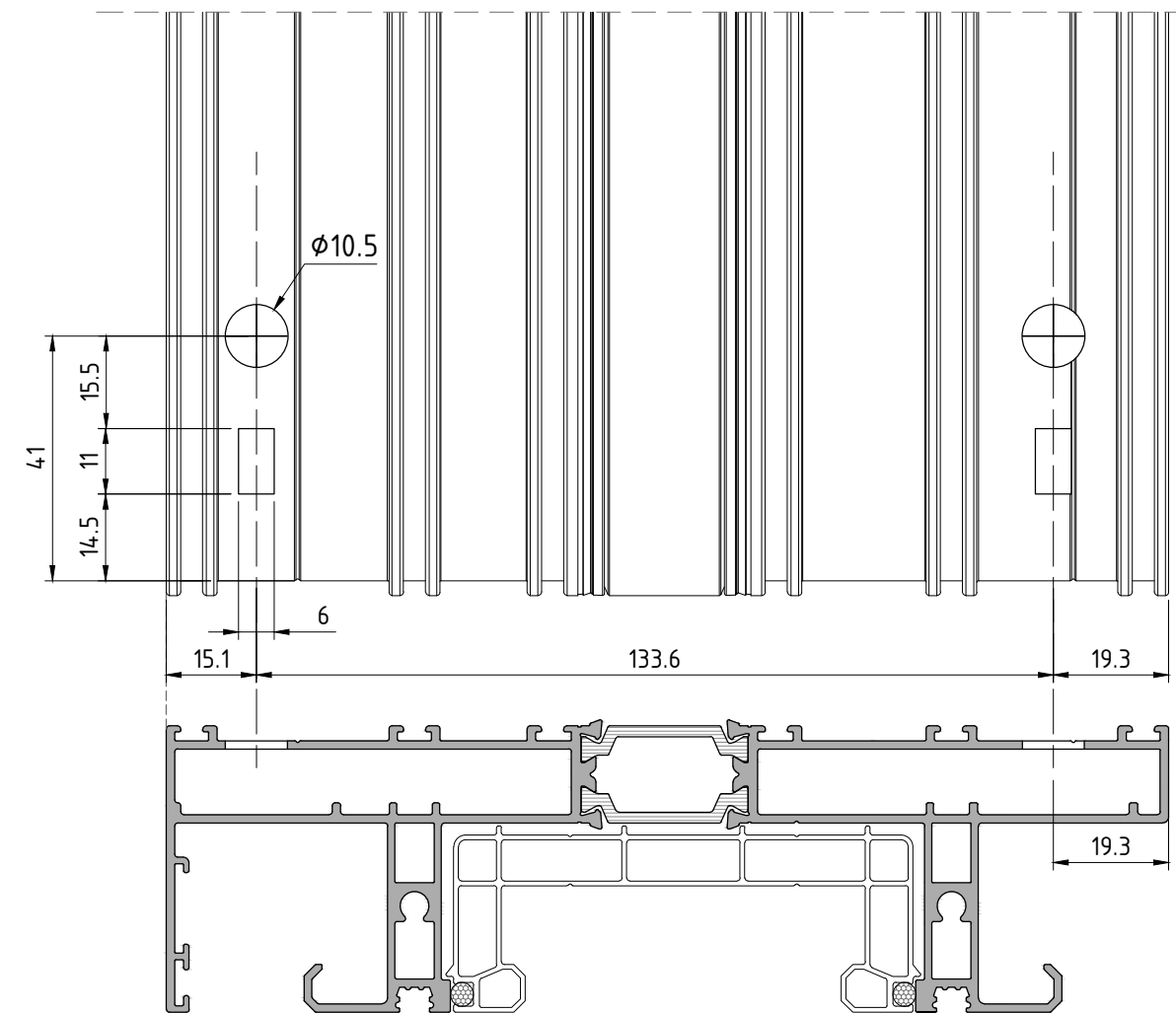

MACHINING ON RAIL FOR FIXING WITH EXTRUDED ALUM. JOINT CORNER BRACKETS

ES70.M-02

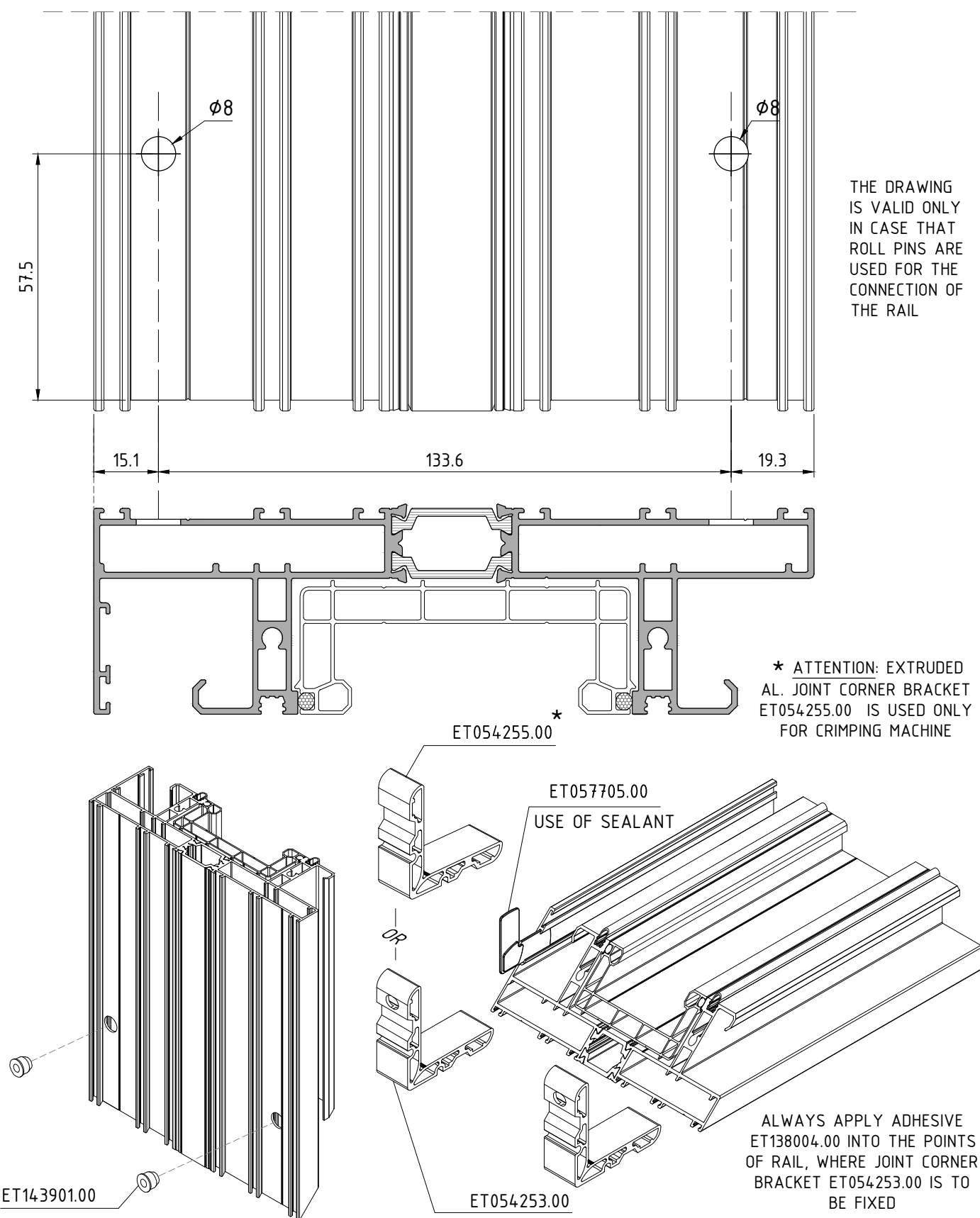

FIXING SASH FRAME WITH EXTRUDED ALUM. JOINT CORNER BRACKETS

ES70.M-03

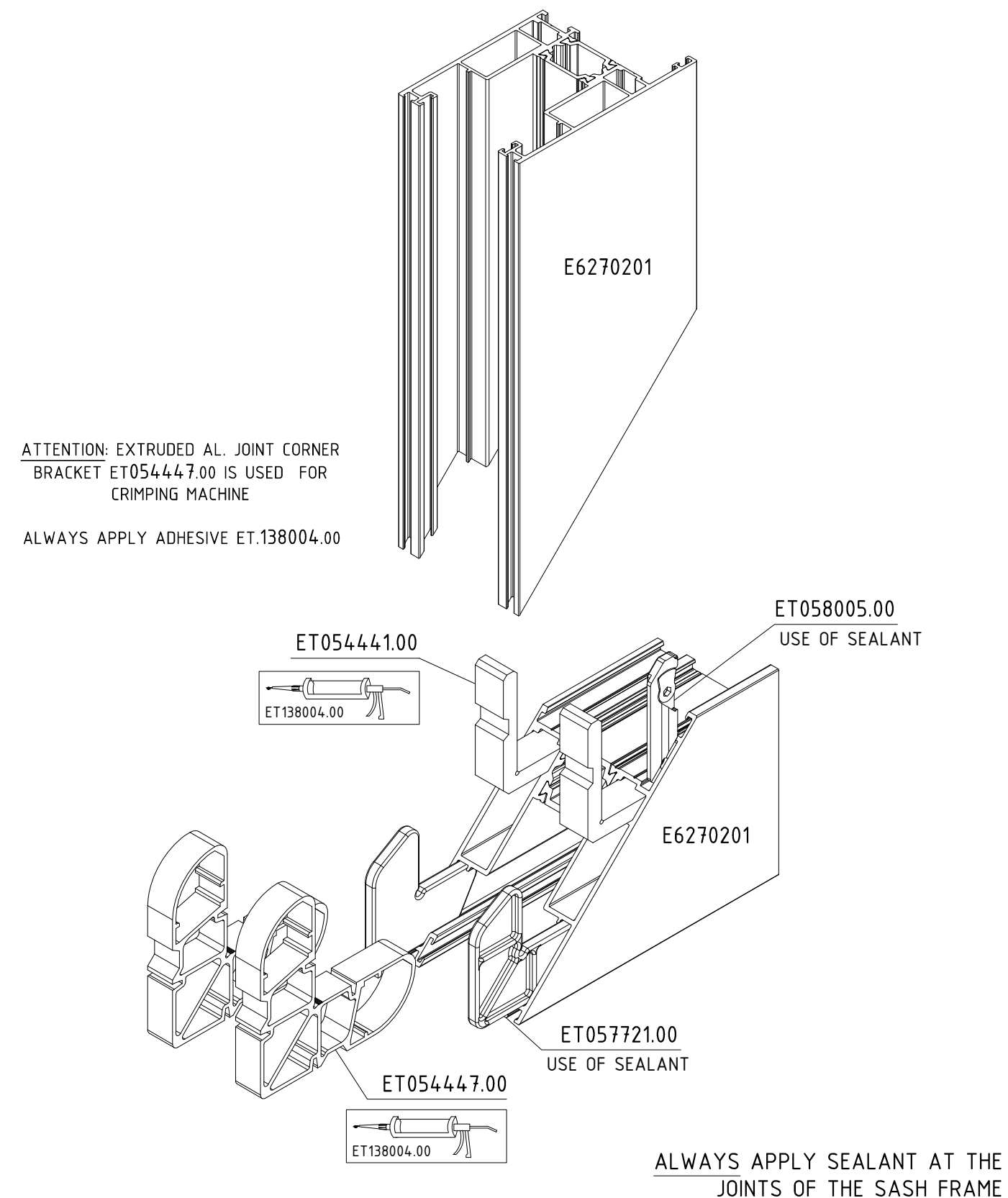

sliding system with thermal break

ES70

MACHINING ON SASH PROFILE FOR FIXING WITH DIE CAST JOINT CORNER BRACKET

ES70.M-04

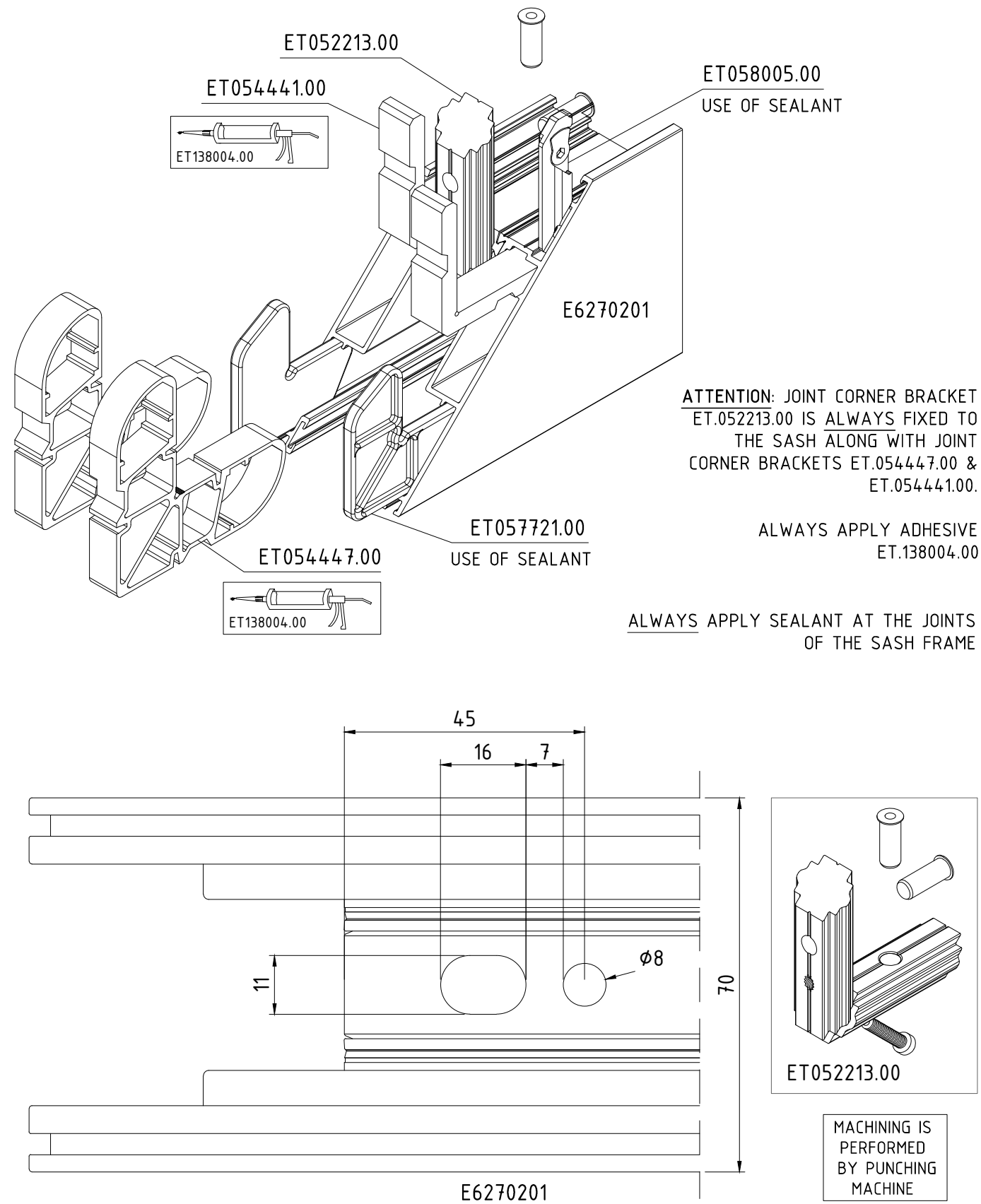

sliding system with thermal break

ES70

MACHINING ON HORIZ. SASH E6270201 FOR CONNECTION WITH NARROW SASH E6270250

ES70.M-05

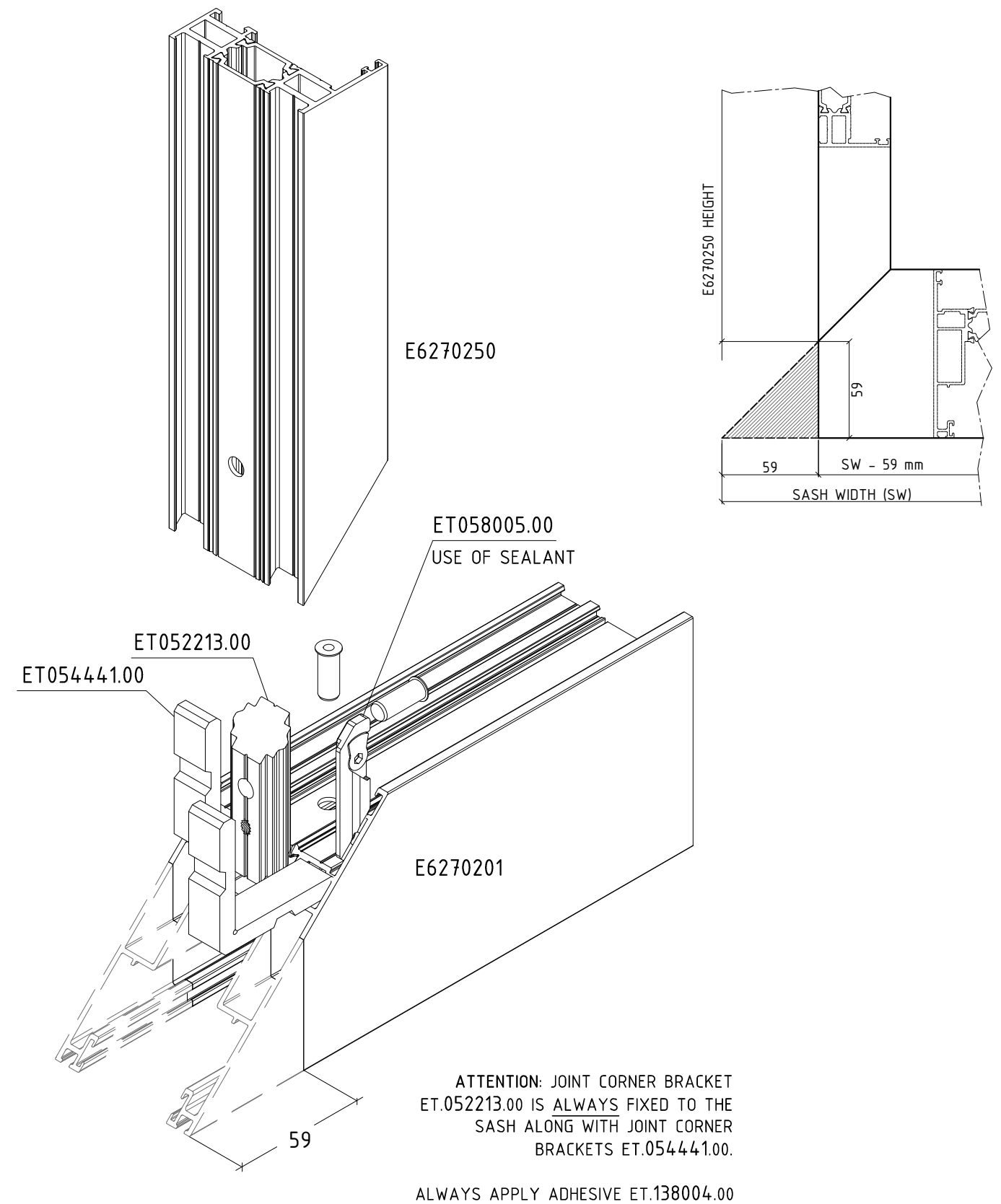

MACHINING ON SASH PROFILE FOR DRAIN HOLES

ES70.M-06

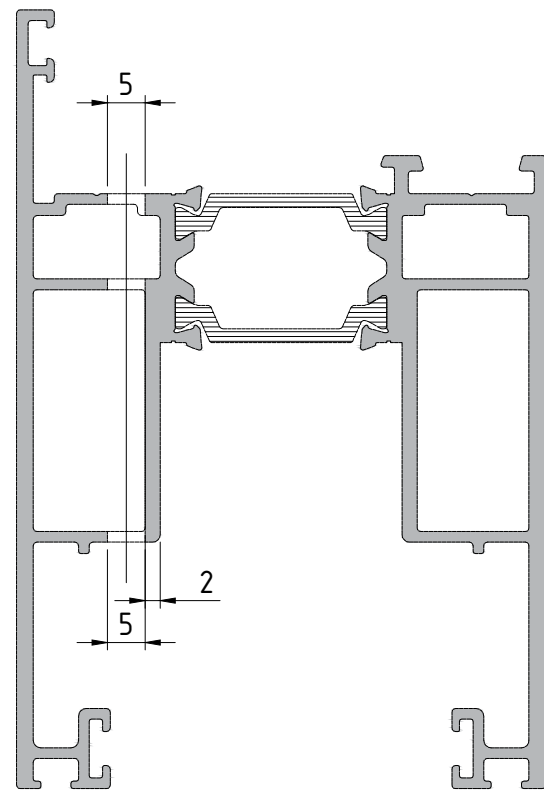

THE DRAIN HOLES ARE OPENED AT THE PUNCHING MACHINE

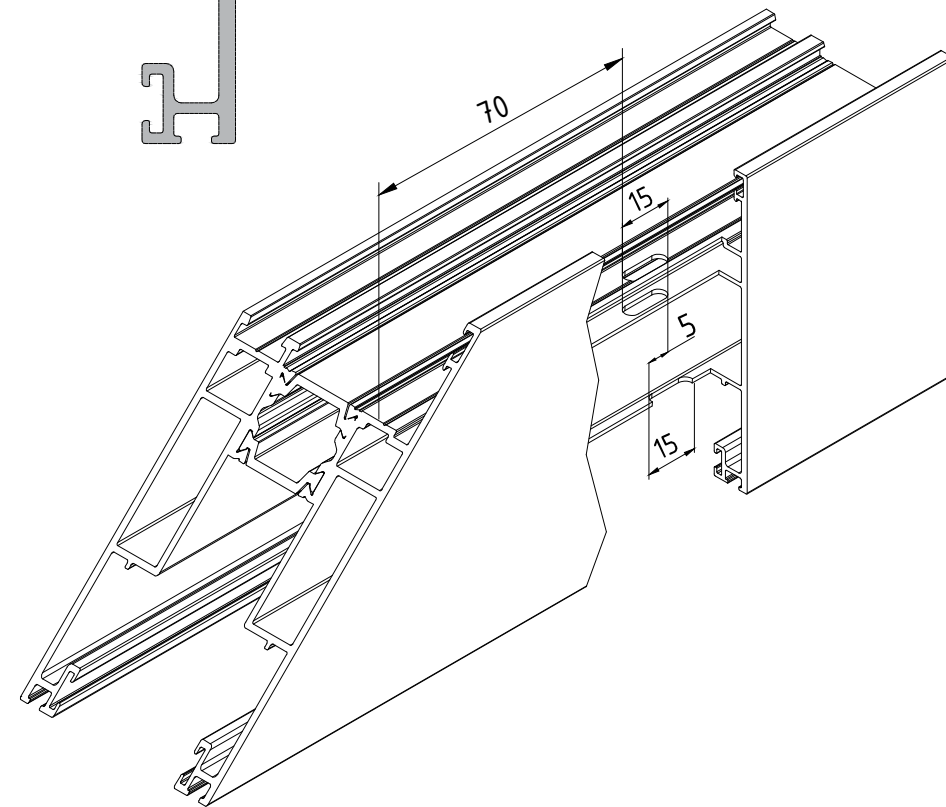

MACHINING ON FLY SCREEN FOR FIXING WITH DIE CAST JOINT CORNER BRACKET & INSTRUCTIONS FOR CONNECTION WITH NARROW FLY SCREEN E22216

ES70.M-07

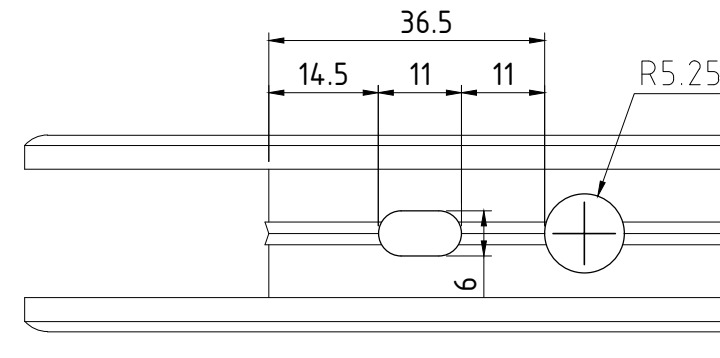

MACHINING IS PERFORMED BY PUNCHING MACHINE
OPTIONAL

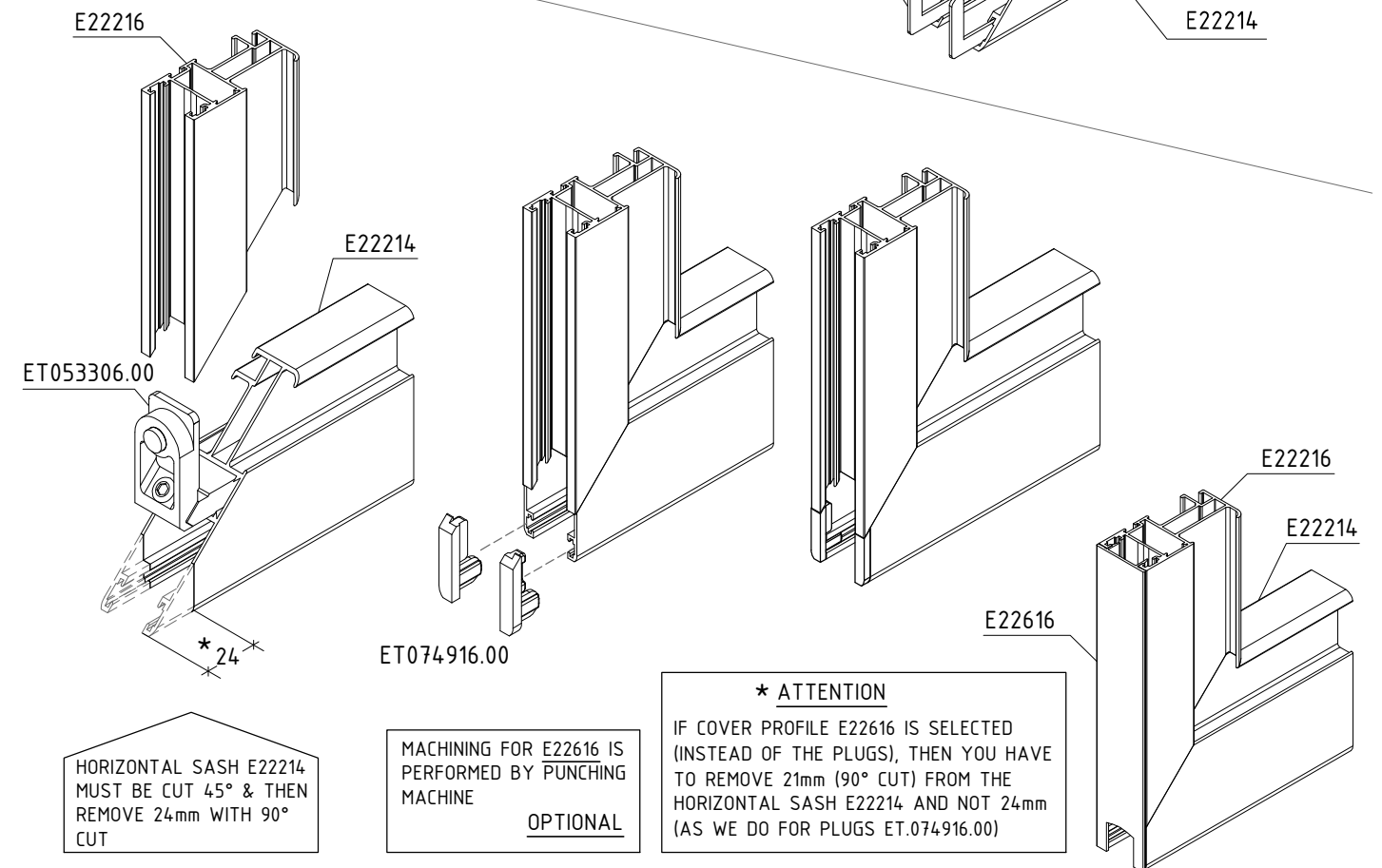
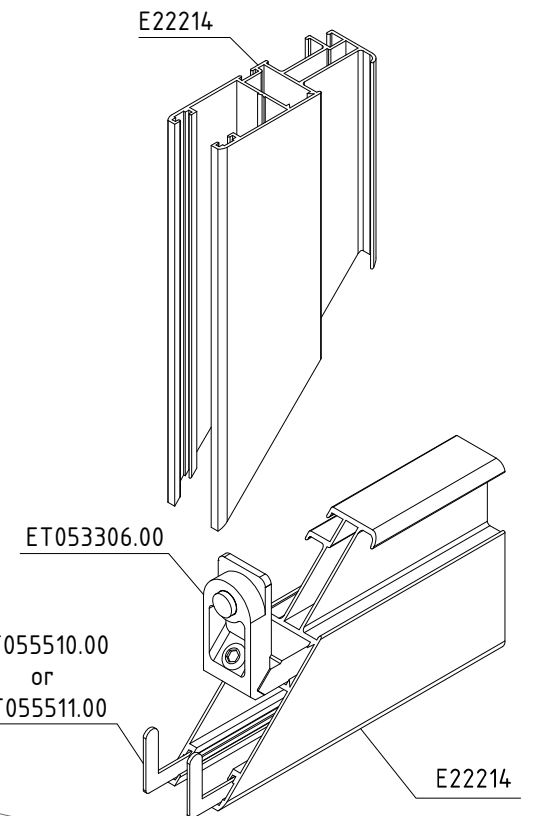

HORIZONTAL SASH E22214 MUST BE CUT 45° & THEN REMOVE 24mm WITH 90° CUT

MACHINING FOR E22616 IS PERFORMED BY PUNCHING MACHINE
OPTIONAL

*** ATTENTION**
IF COVER PROFILE E22616 IS SELECTED (INSTEAD OF THE PLUGS), THEN YOU HAVE TO REMOVE 21mm (90° CUT) FROM THE HORIZONTAL SASH E22214 AND NOT 24mm (AS WE DO FOR PLUGS ET.074916.00)

MACHINING OF INTERLOCK PROFILE E6270501

ES70.M-08

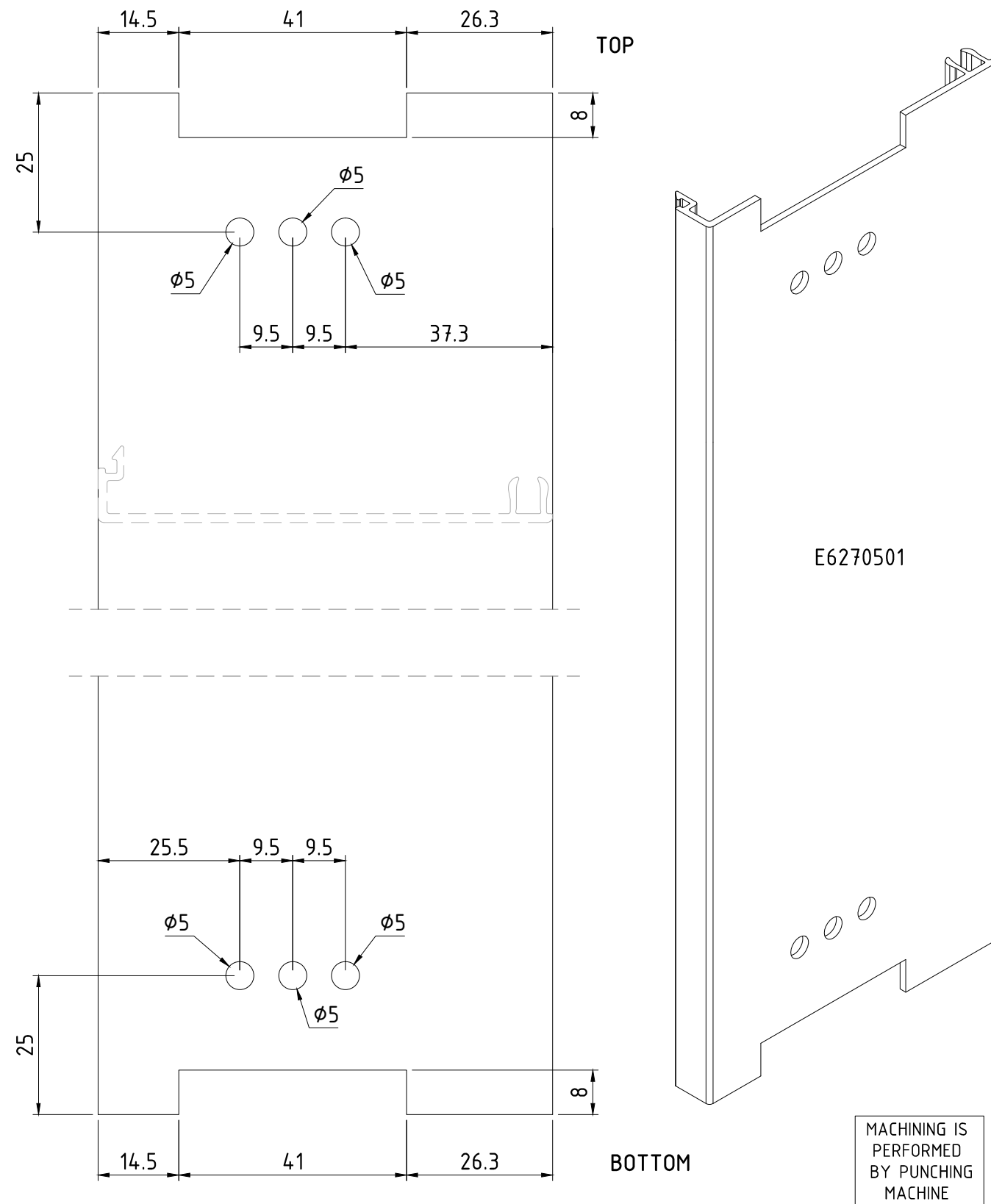

MACHINING IS PERFORMED BY PUNCHING MACHINE

FIXING INTERLOCK PROFILE E6270501

ES70.M-09

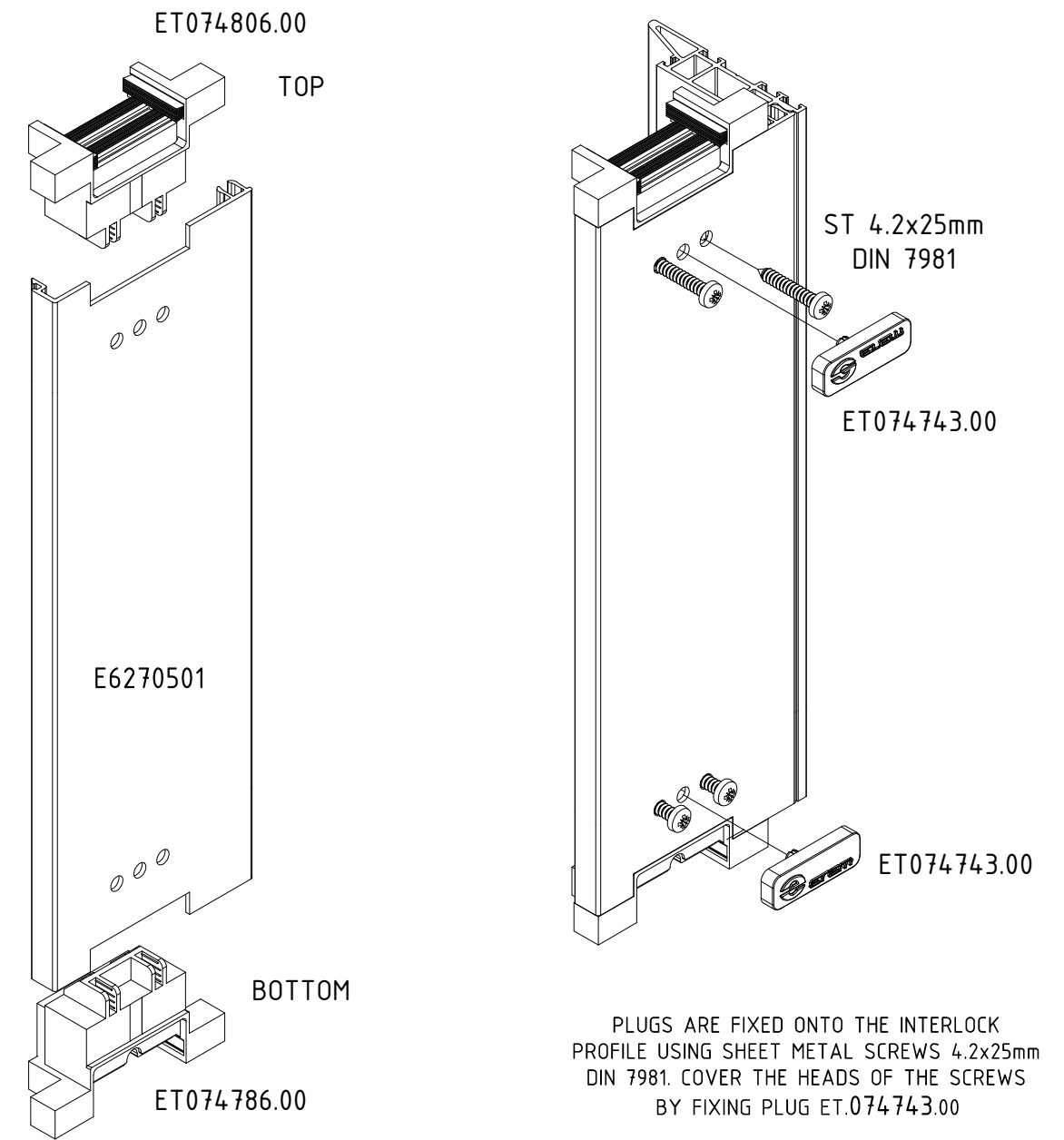

PLUG ET.07478600 IS FIXED ONTO THE BOTTOM SIDE OF INTERLOCK PROFILE E6270501, WHILST PLUG ET.074806.00 IS FIXED ONTO THE TOP SIDE

PLUGS ARE FIXED ONTO THE INTERLOCK PROFILE USING SHEET METAL SCREWS 4.2x25mm DIN 7981. COVER THE HEADS OF THE SCREWS BY FIXING PLUG ET.074743.00

FIXING INTERLOCK PROFILE ONTO THE SASH FRAME

ES70.M-010

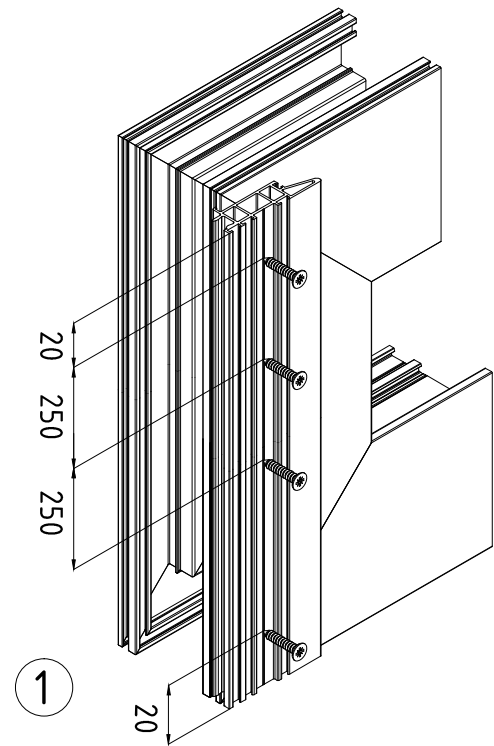

E6270501

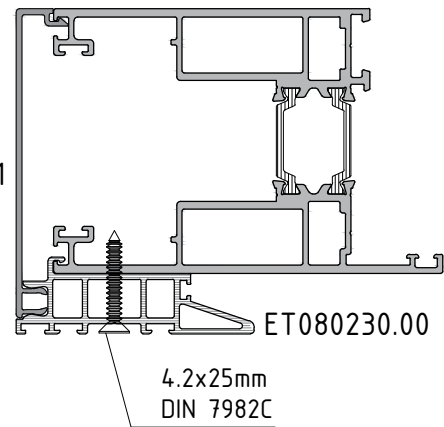

PLASTIC SPACER ET080230.00 IS FIXED ONTO THE SASH FRAME USING SHEET METAL SCREWS 4.2x25mm DIN 7982C. THE FIRST SCREW IS FIXED AT A DISTANCE OF 20mm, MEASURED FOR THE ENDS OF PROFILE E6270501, AND THE CENTER TO CENTER DISTANCE BETWEEN THE NEXT SCREWS MUST BE APPROXIMATELY 250mm.

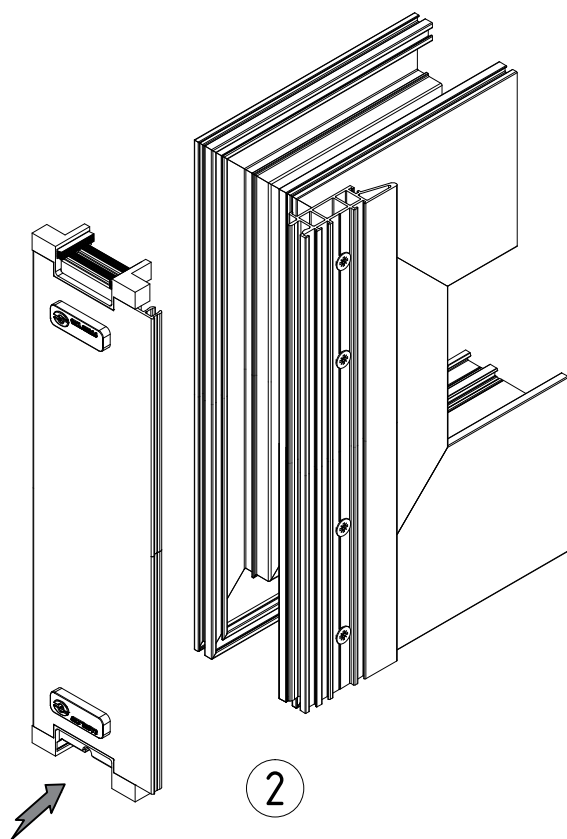

ET074811.00

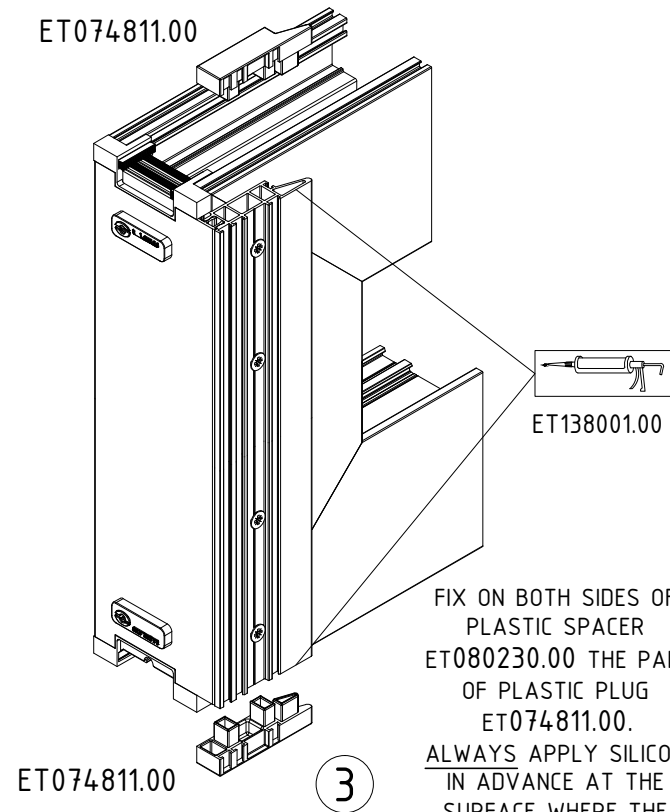

FIX ON BOTH SIDES OF PLASTIC SPACER ET080230.00 THE PAIR OF PLASTIC PLUG ET074811.00. ALWAYS APPLY SILICON IN ADVANCE AT THE SURFACE WHERE THE PLUG IS TO BE FIXED

MACHINING OF INTERLOCK PROFILE FOR NARROW SASH FRAME

ES70.M-011

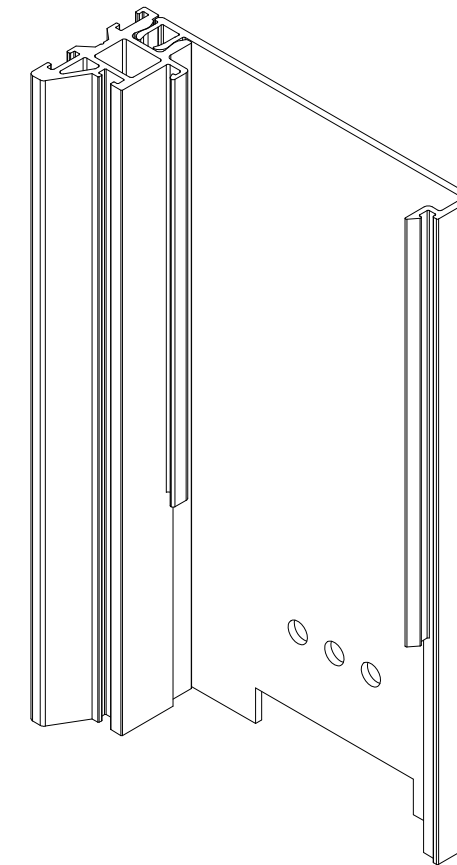
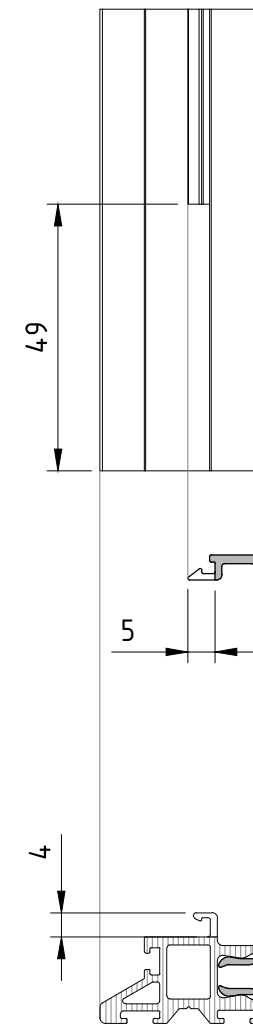

E6270501

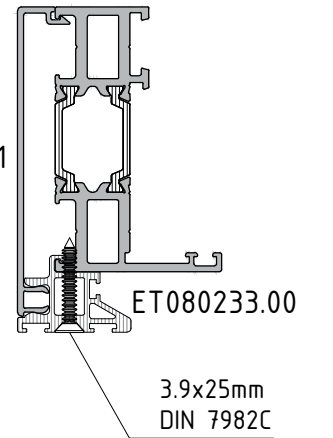

PLUG ET.074786.00 IS FIXED ONTO THE BOTTOM SIDE OF INTERLOCK PROFILE, WHILST PLUG ET.074806.00 IS FIXED ONTO THE TOP SIDE

ET074786.00

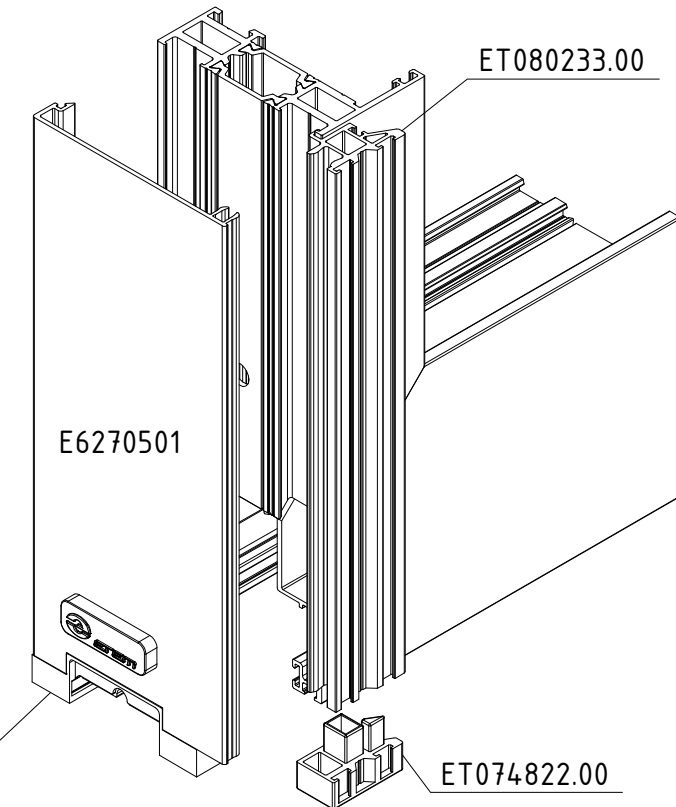

FIX ON BOTH SIDES OF PLASTIC SPACER ET080233.00 THE PAIR OF PLASTIC PLUG ET074822.00. ALWAYS APPLY SILICON IN ADVANCE AT THE SURFACE WHERE THE PLUG IS TO BE FIXED

ET074822.00

MACHINING REQUIRED FOR 90° CONNECTION OF RAILS

ES70.M-012

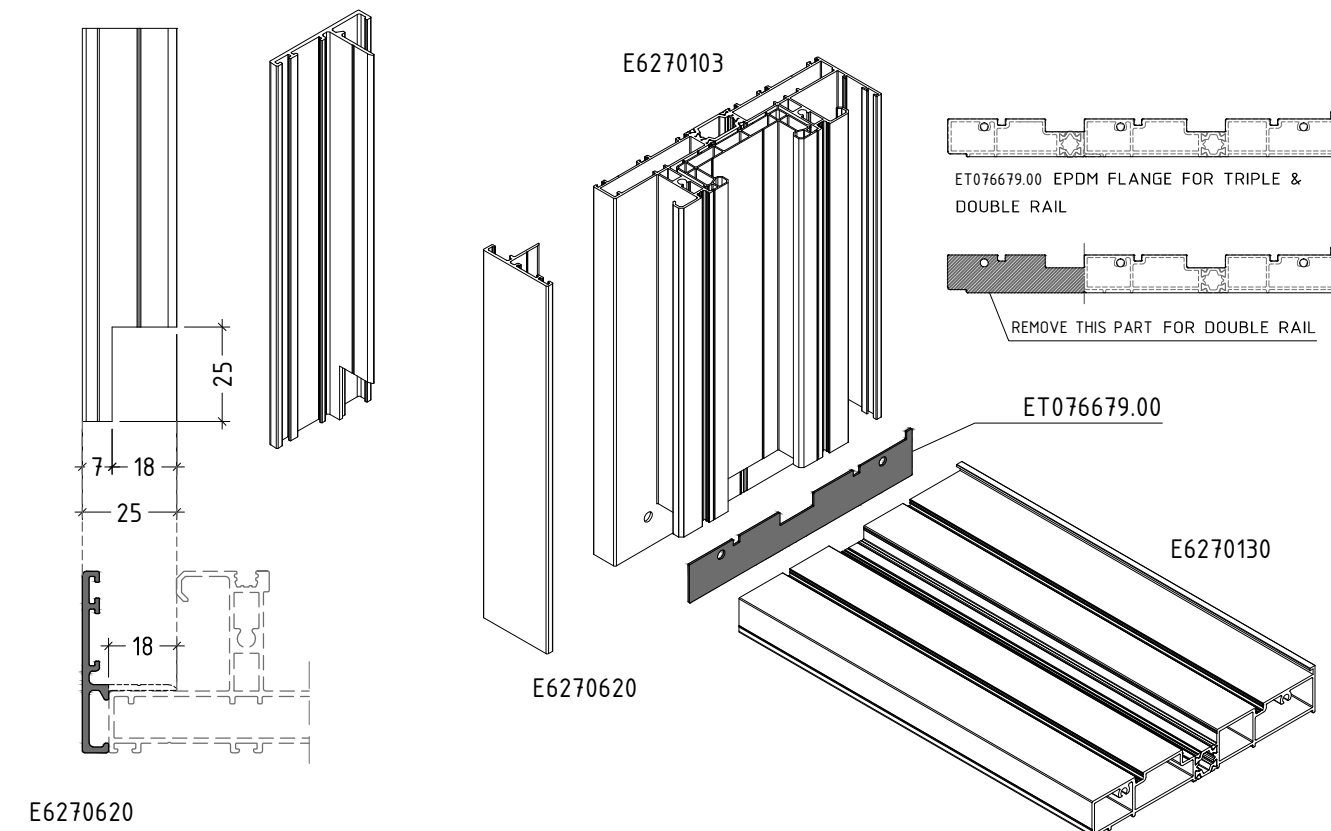
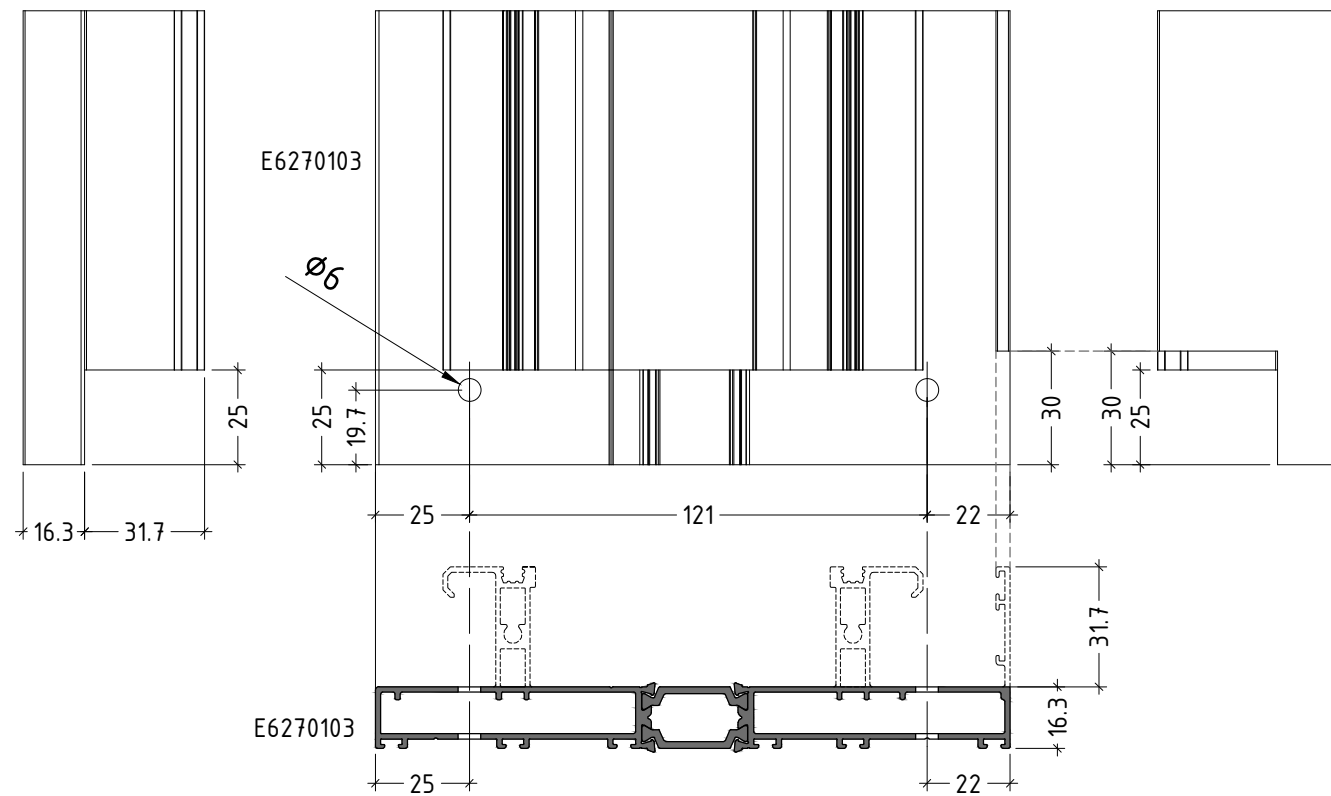

E6270620

MACHINING REQUIRED FOR 90° CONNECTION OF RAILS

ES70.M-013

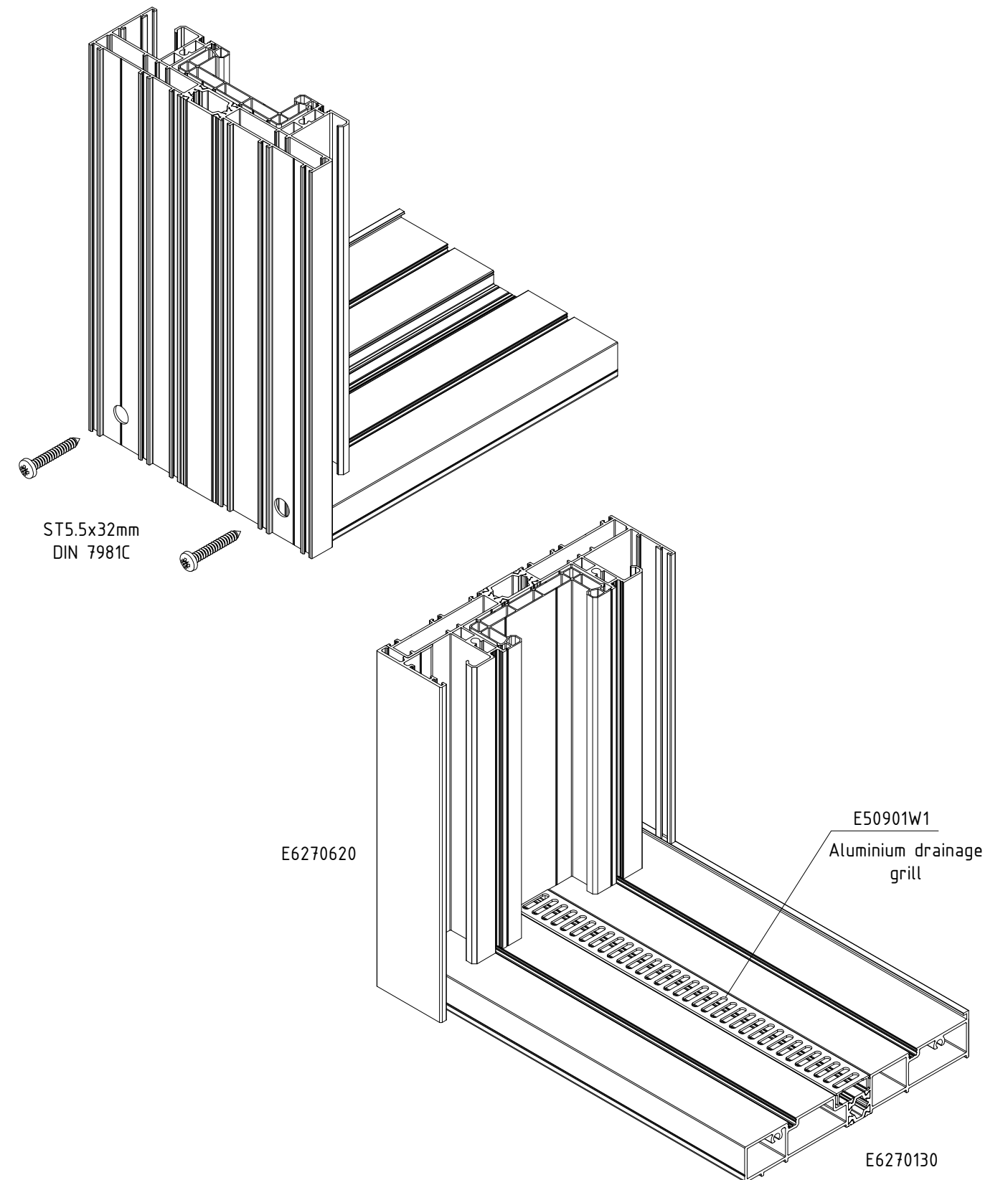

sliding system with thermal break

ES70

HANDLE MACHINING FOR SASH E6270201 (GU HARDWARE)

ES70.M-014

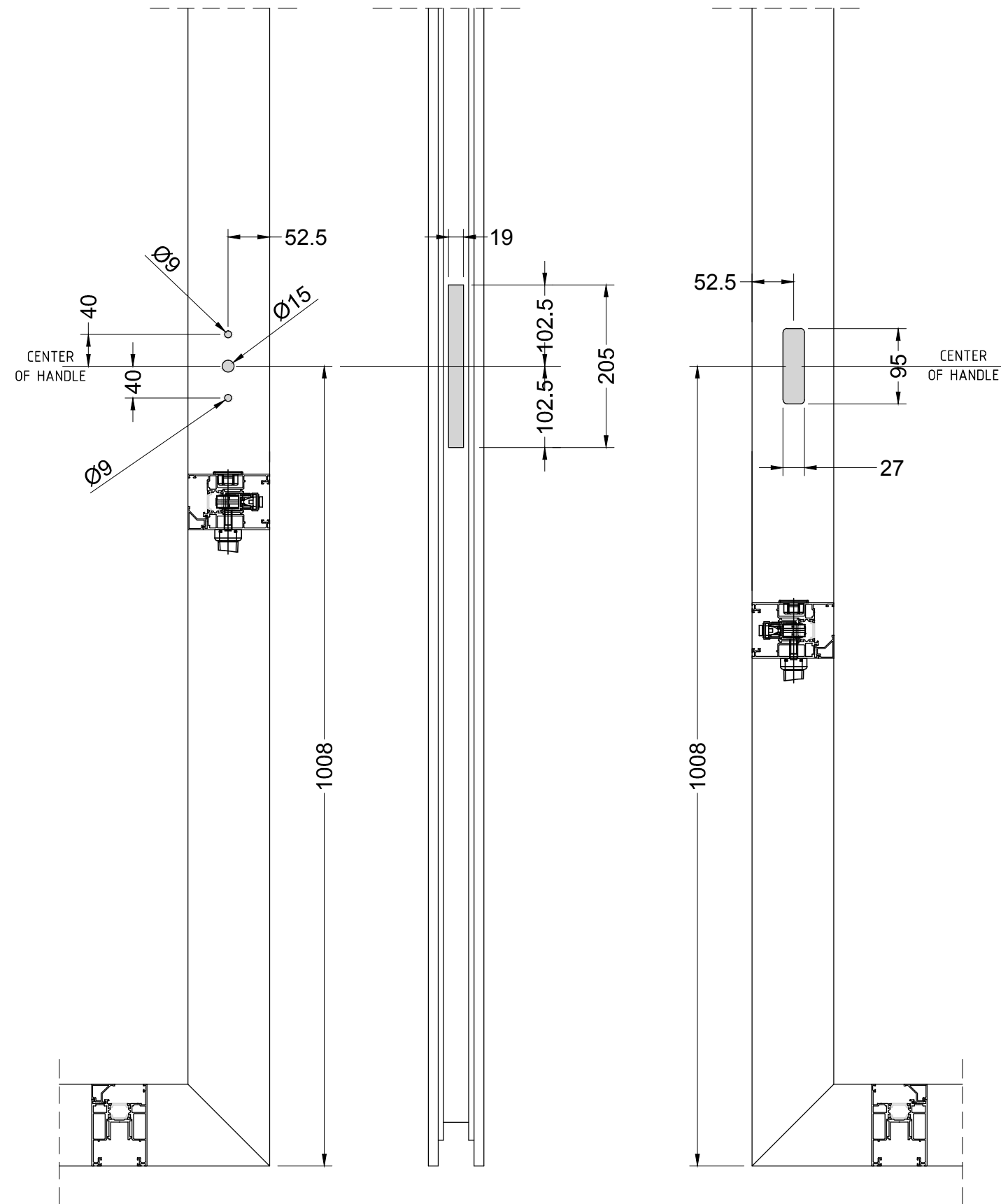

sliding system with thermal break

ES70

LIFT & SLIDE MECHANISM INSTALLATION ON SASH E6270201

ES70.M-015

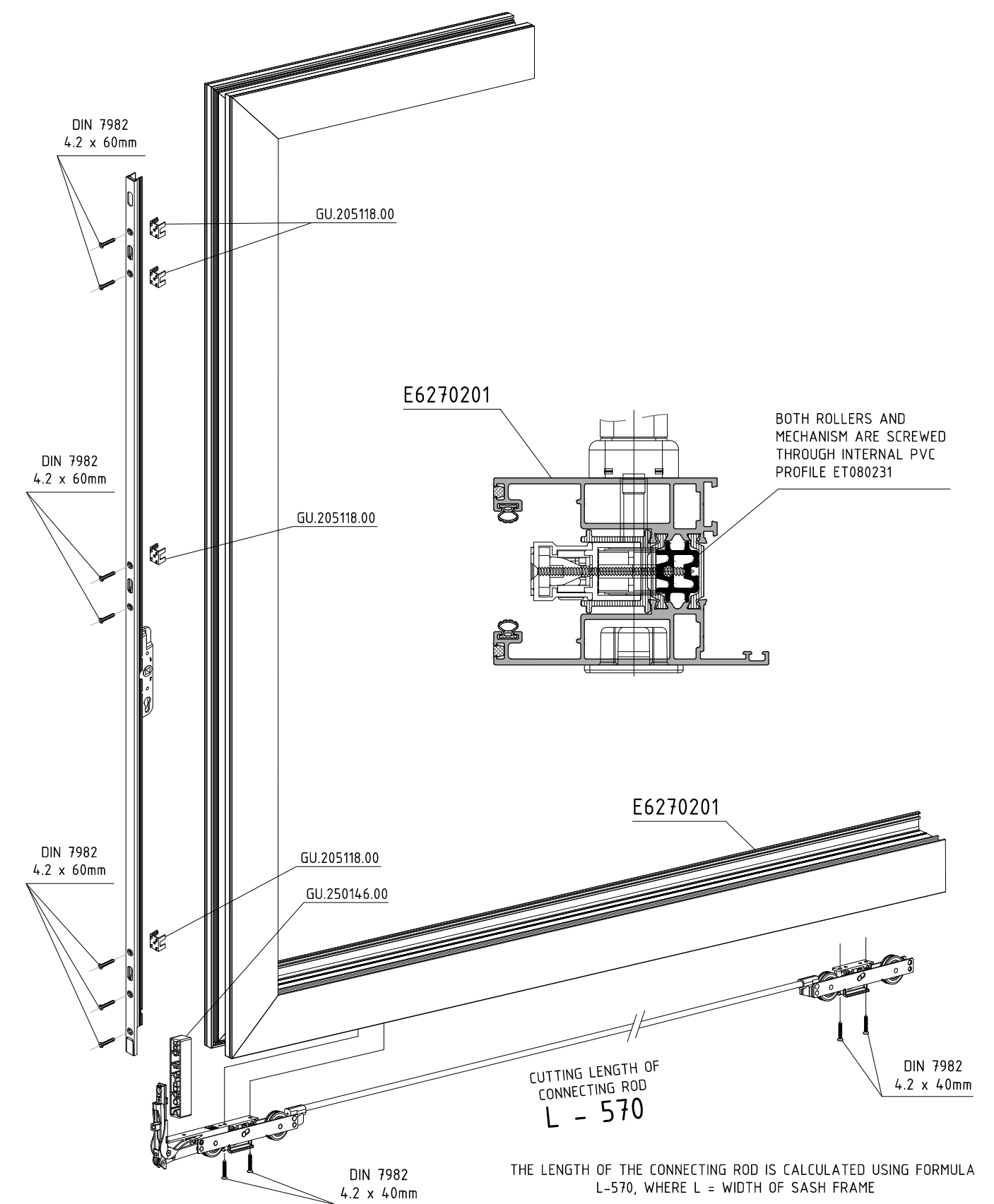

sliding system with thermal break

ES70

HANDLE MACHINING FOR SASH E6270201 (GU HARDWARE) - ONLY FOR FLAT RAIL

ES70.M-016

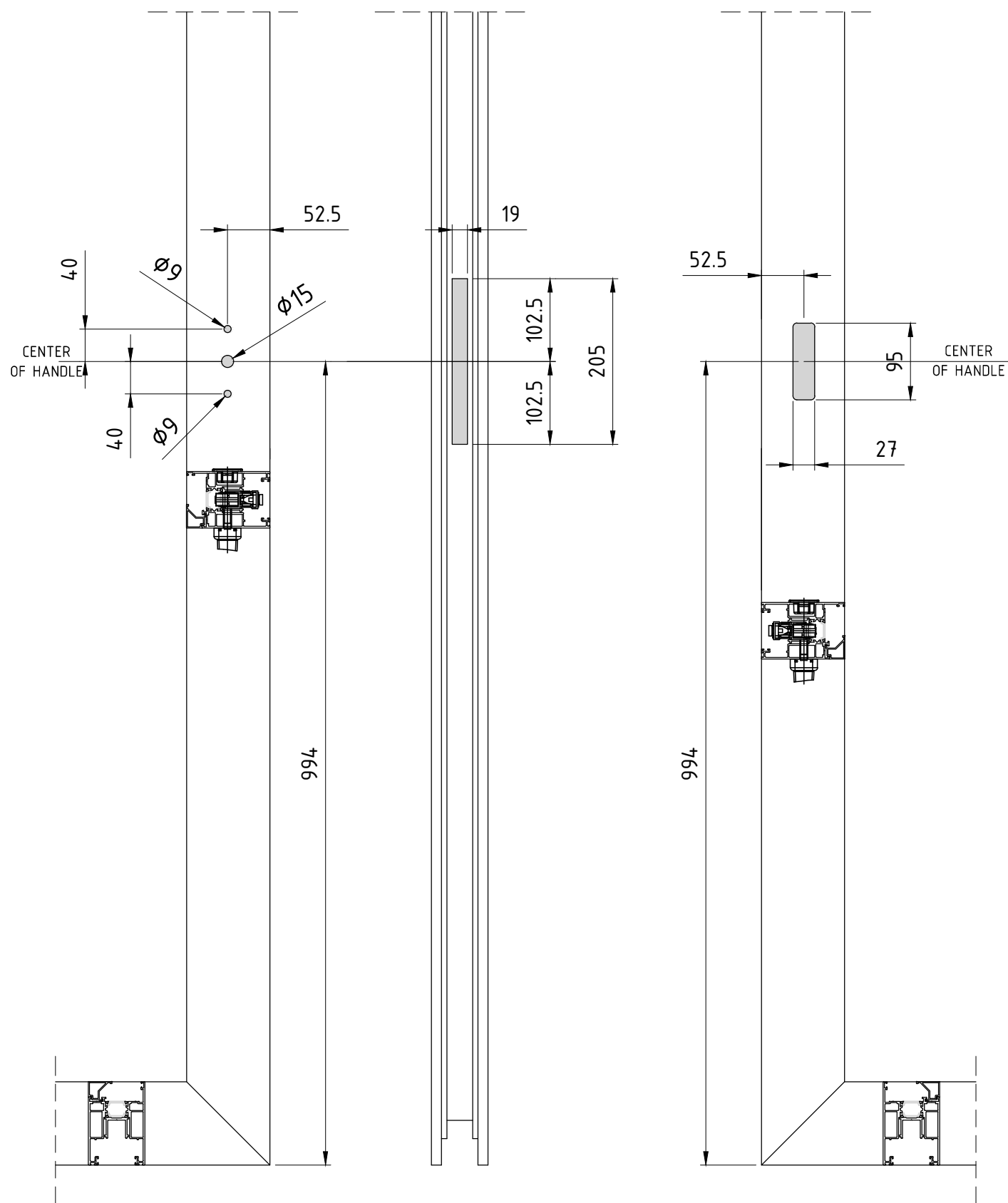

sliding system with thermal break

ES70

LIFT & SLIDE MECHANISM INSTALLATION ON SASH E6270201 - ONLY FOR FLAT RAIL

ES70.M-017

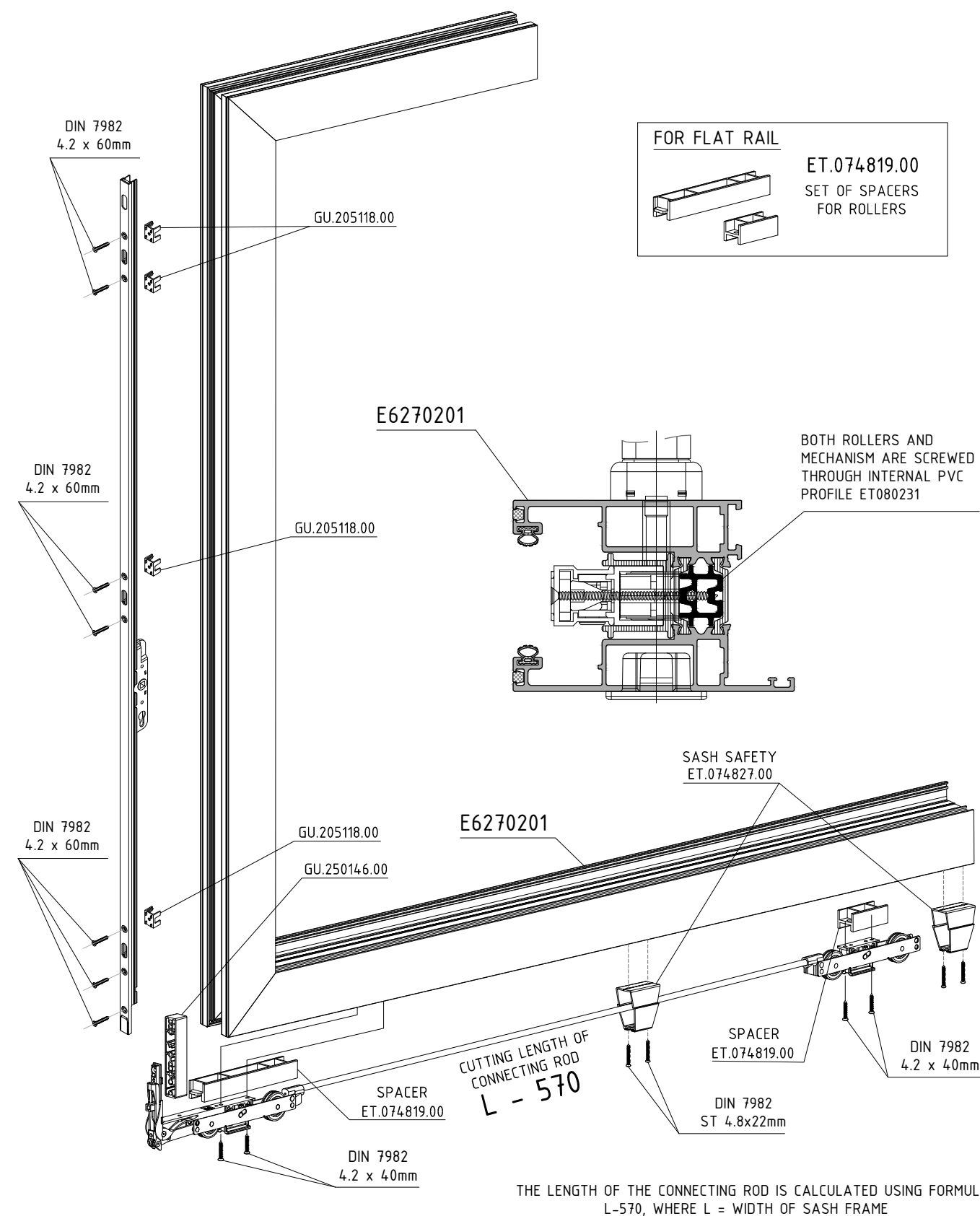

sliding system with thermal break

ES70

FIXING RAIL WITH EXTRUDED ALUM. JOINT CORNER BRACKETS - HOTEL TYPE

ES70.M-018

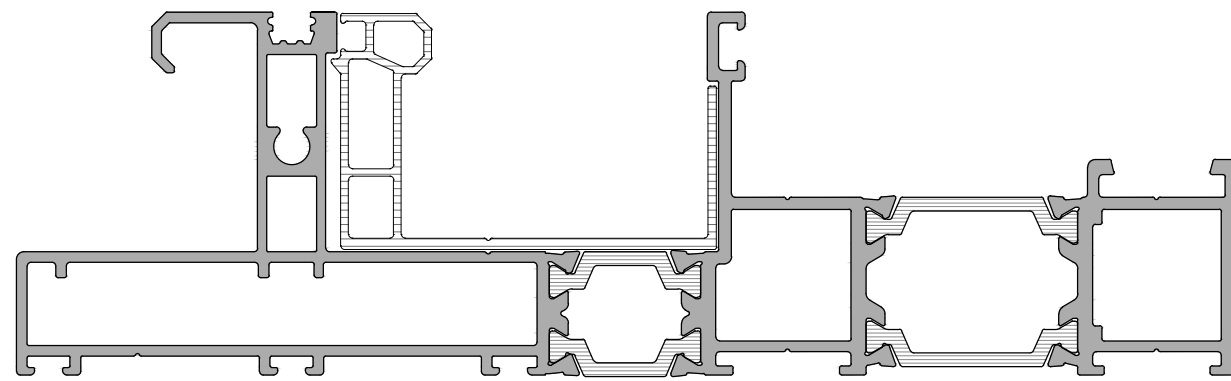

E6270150

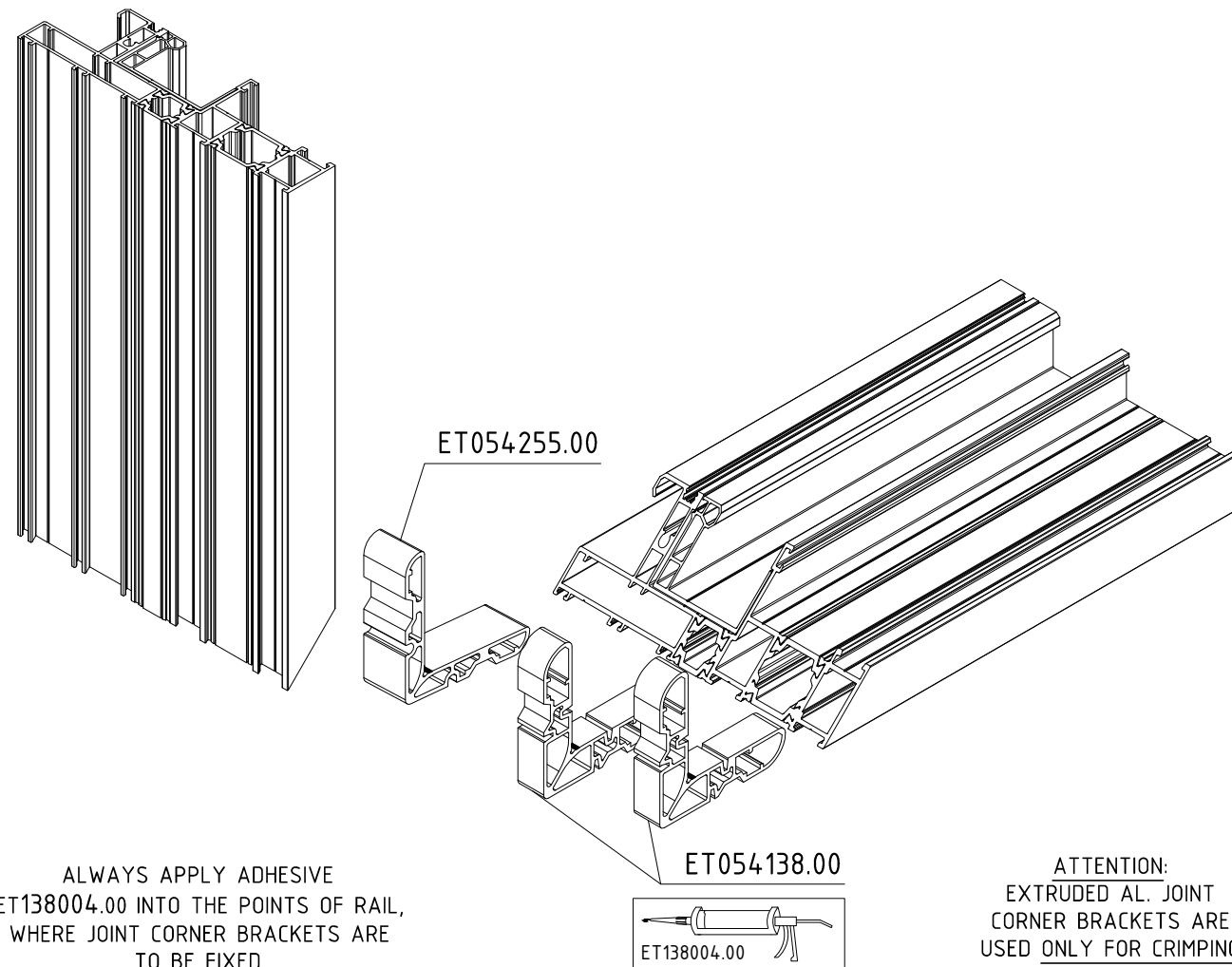

ET054255.00

ET054138.00

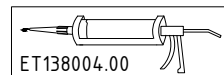

ALWAYS APPLY ADHESIVE
ET138004.00 INTO THE POINTS OF RAIL,
WHERE JOINT CORNER BRACKETS ARE
TO BE FIXED

ATTENTION:
EXTRUDED AL. JOINT
CORNER BRACKETS ARE
USED ONLY FOR CRIMPING
MACHINE

sliding system with thermal break

ES70

MACHINING ON INTERLOCK PROFILE E6270501 - HOTEL TYPE

ES70.M-019

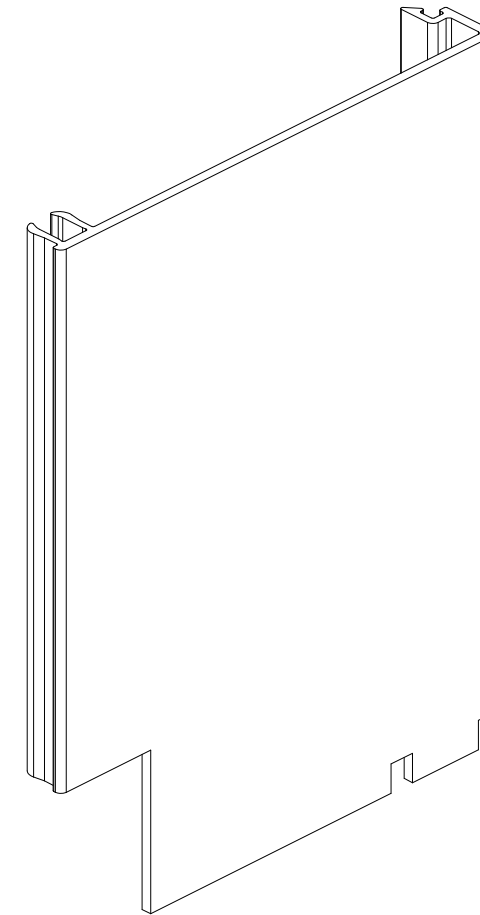

MILLING CUT

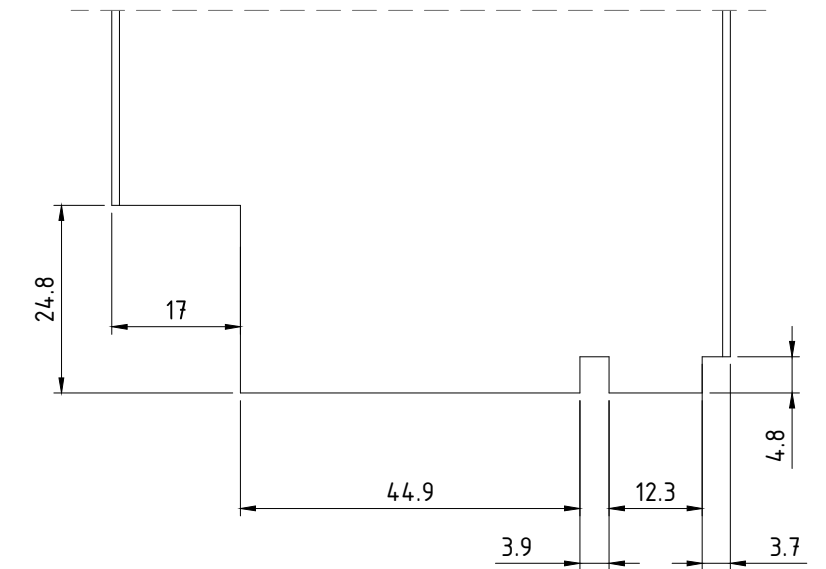

Interlock Machining

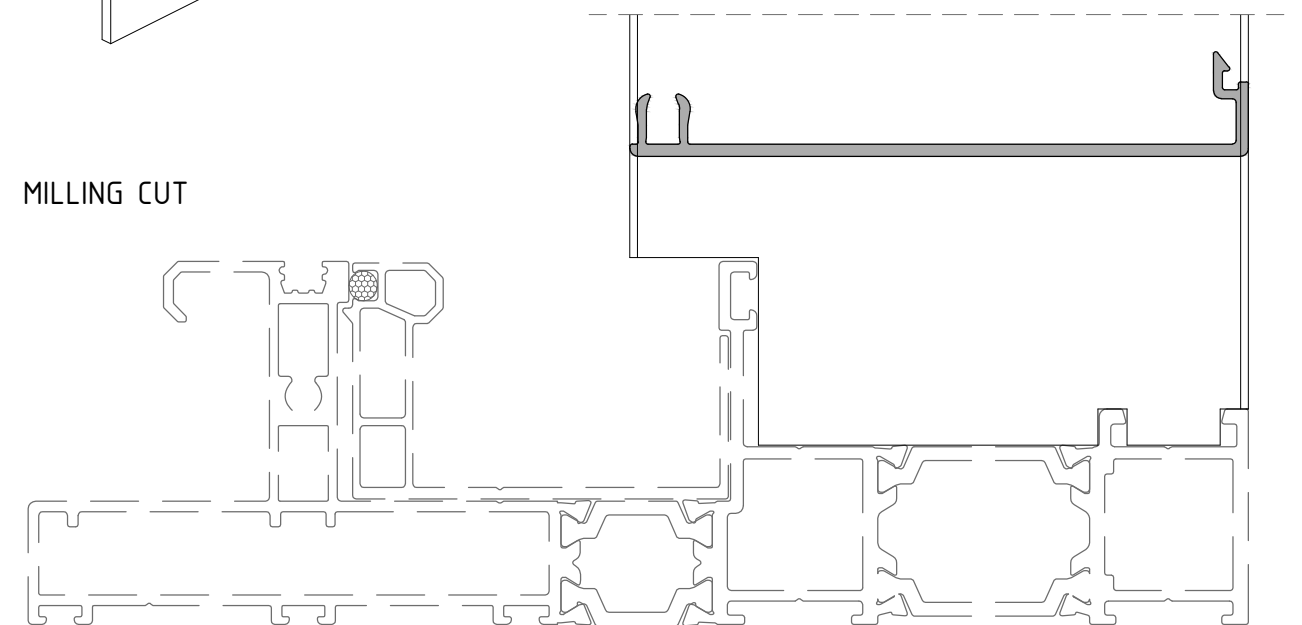

MACHINING ON MULLION E6270350 - HOTEL TYPE

ES70.M-020

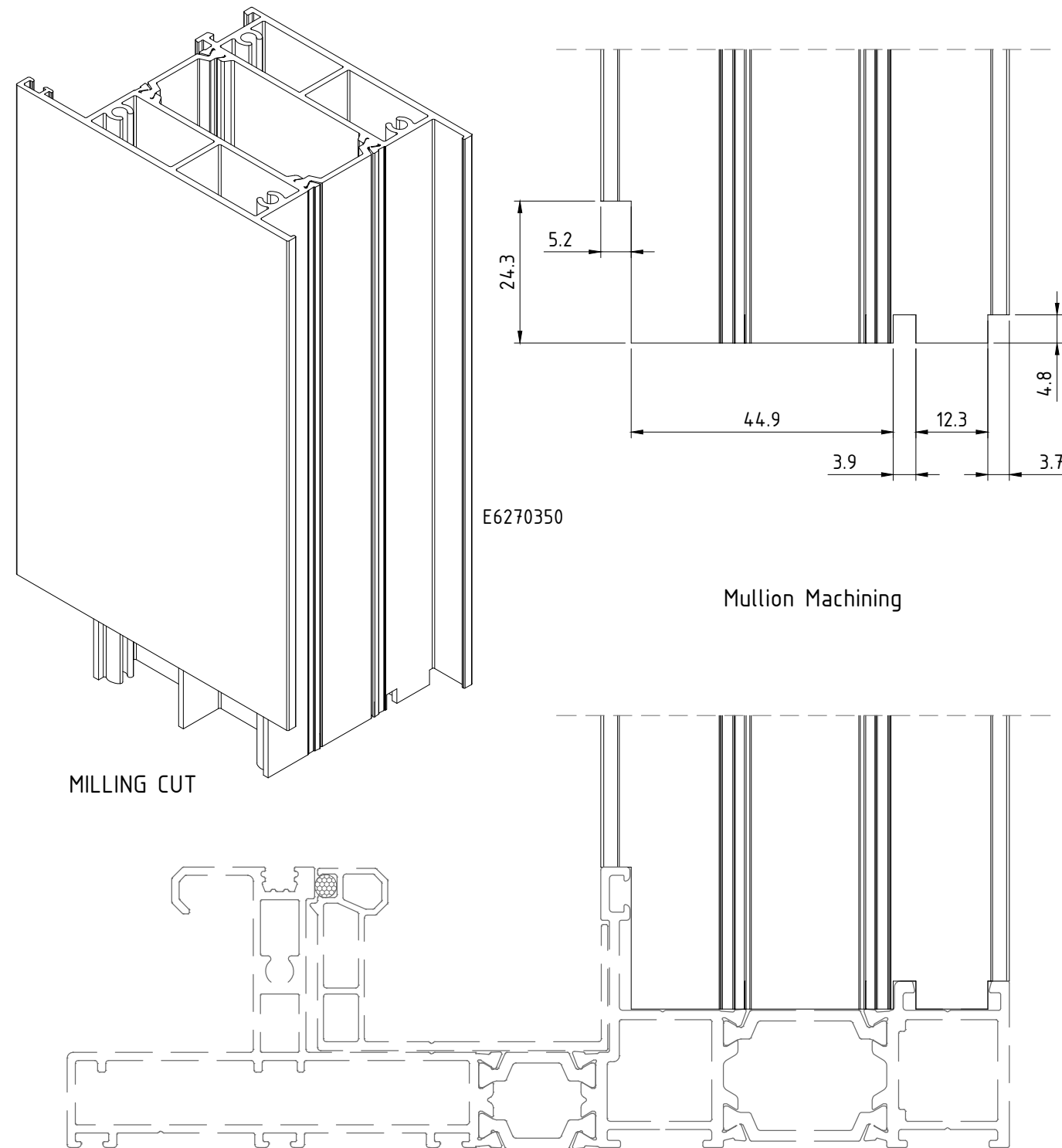

INSTRUCTIONS FOR FITTING SEALING BLOCK - HOTEL TYPE

ES70.M-021

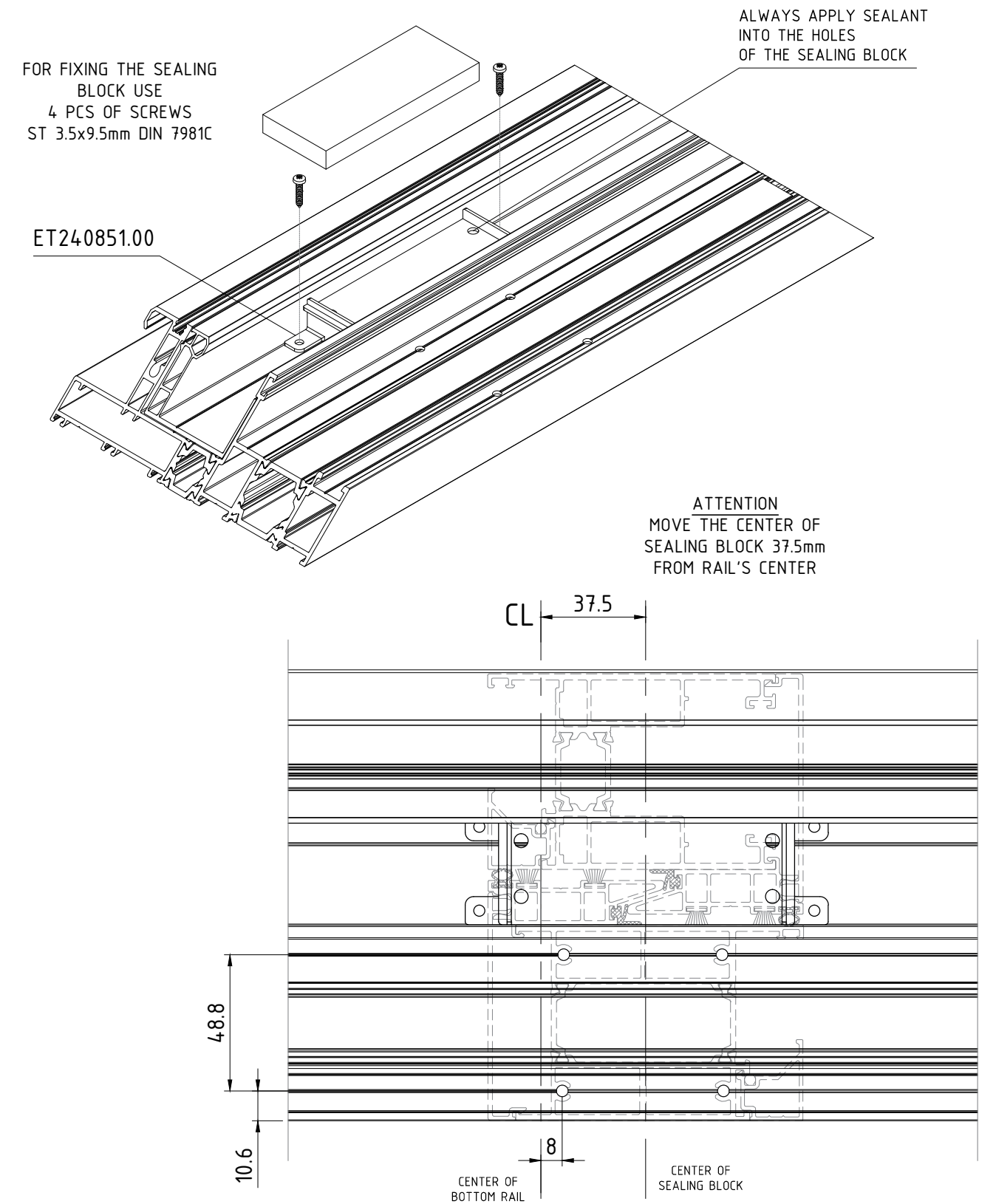

sliding system with thermal break

ES70

FIXING MULLION E6270350 - HOTEL TYPE

ES70.M-022

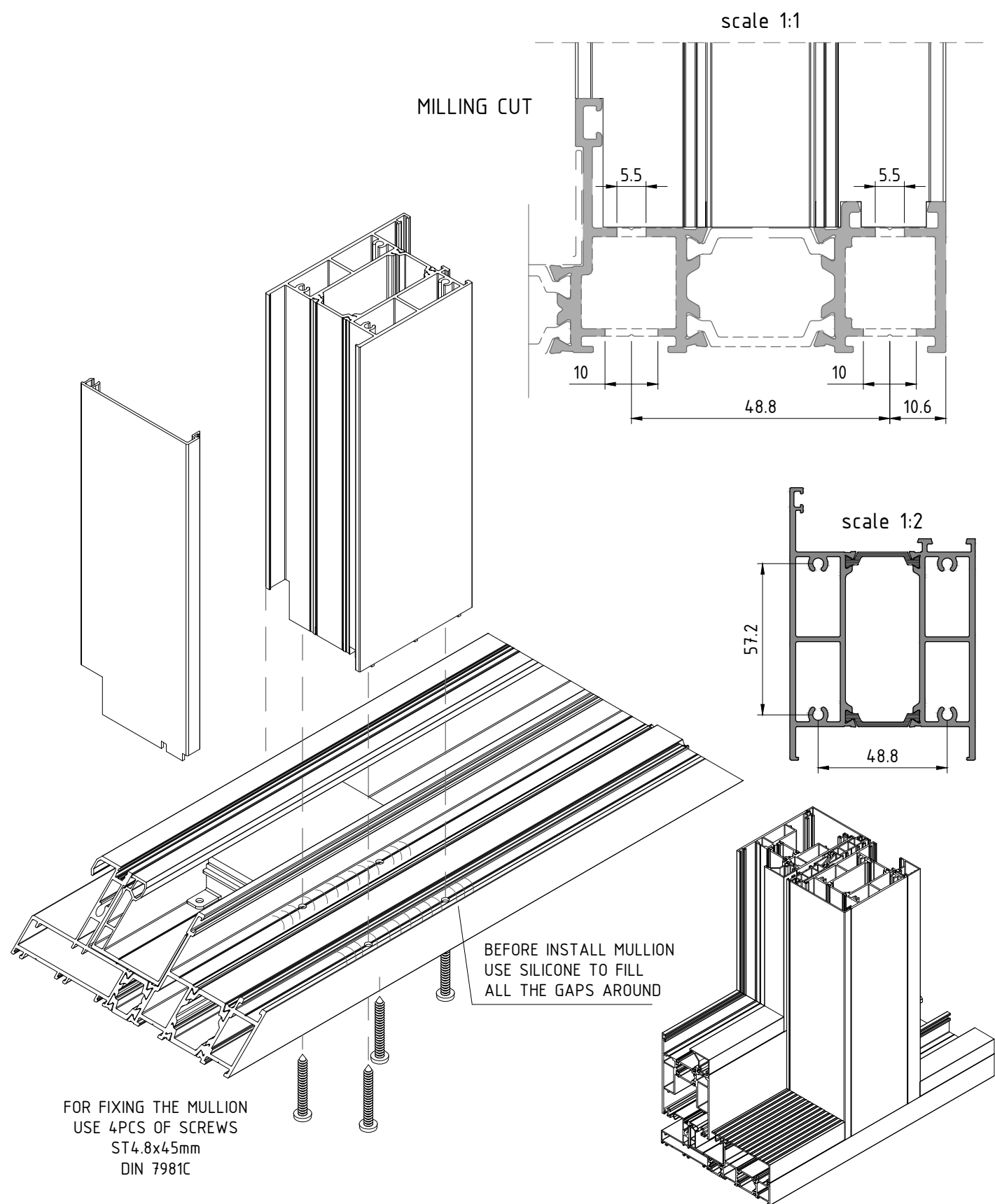

sliding system with thermal break

ES70

FIXING SASH PROFILE E6270201 AS MULLION - HOTEL TYPE

ES70.M-023

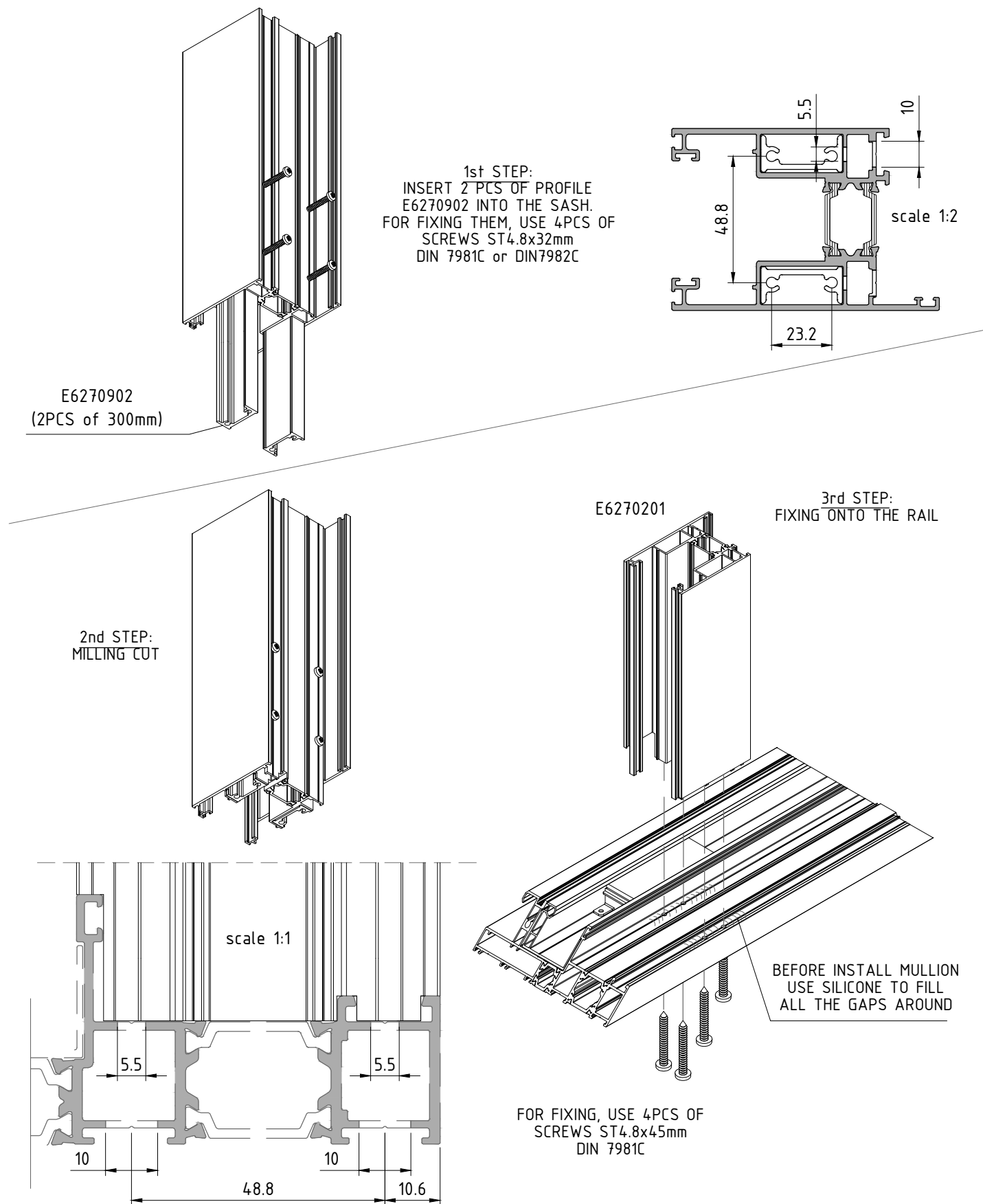

FIXING SASH PROFILE E6270250 AS MULLION - HOTEL TYPE

ES70.M-024

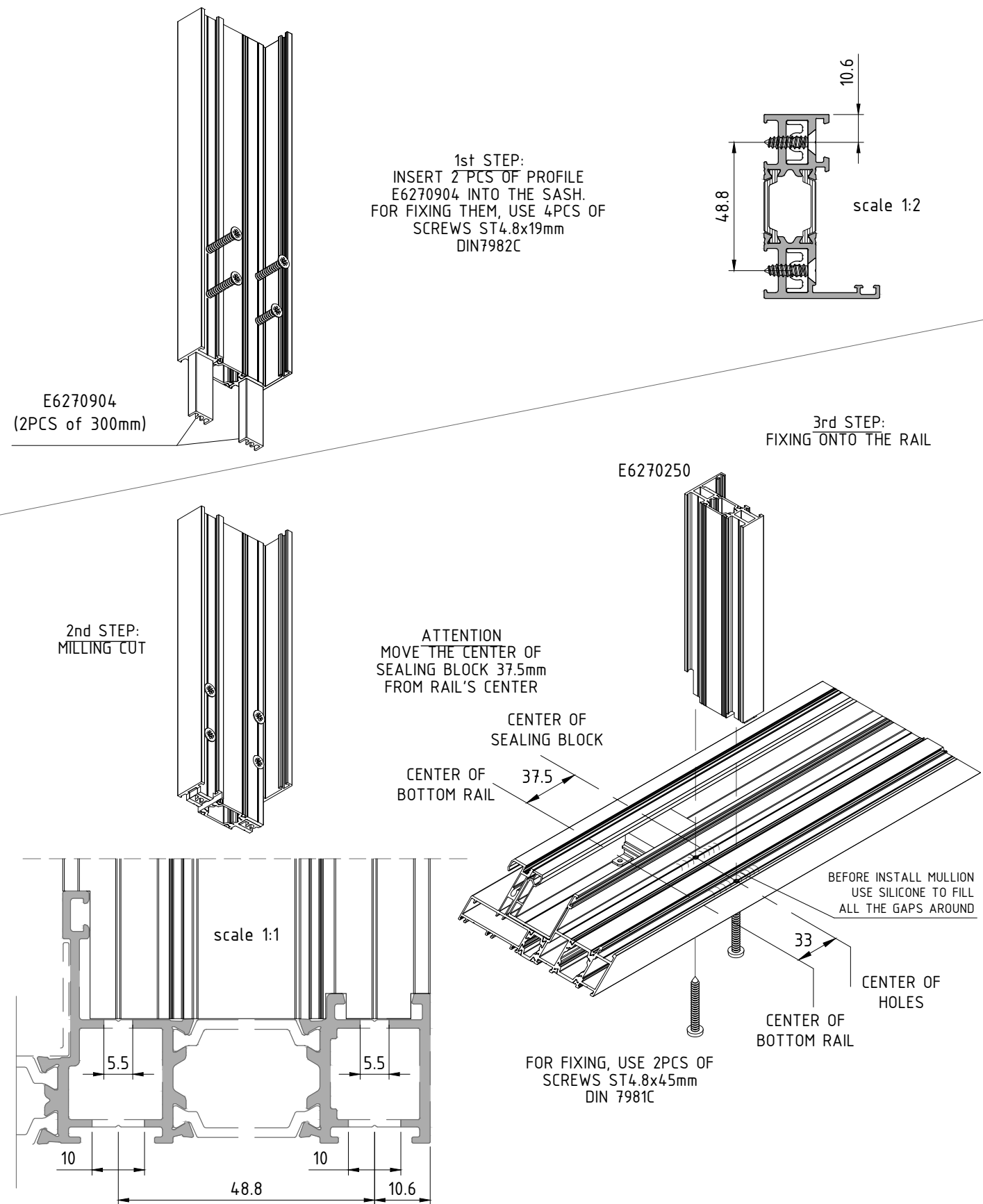

INSTRUCTIONS FOR WATER DRAINAGE - HOTEL TYPE

ES70.M-025

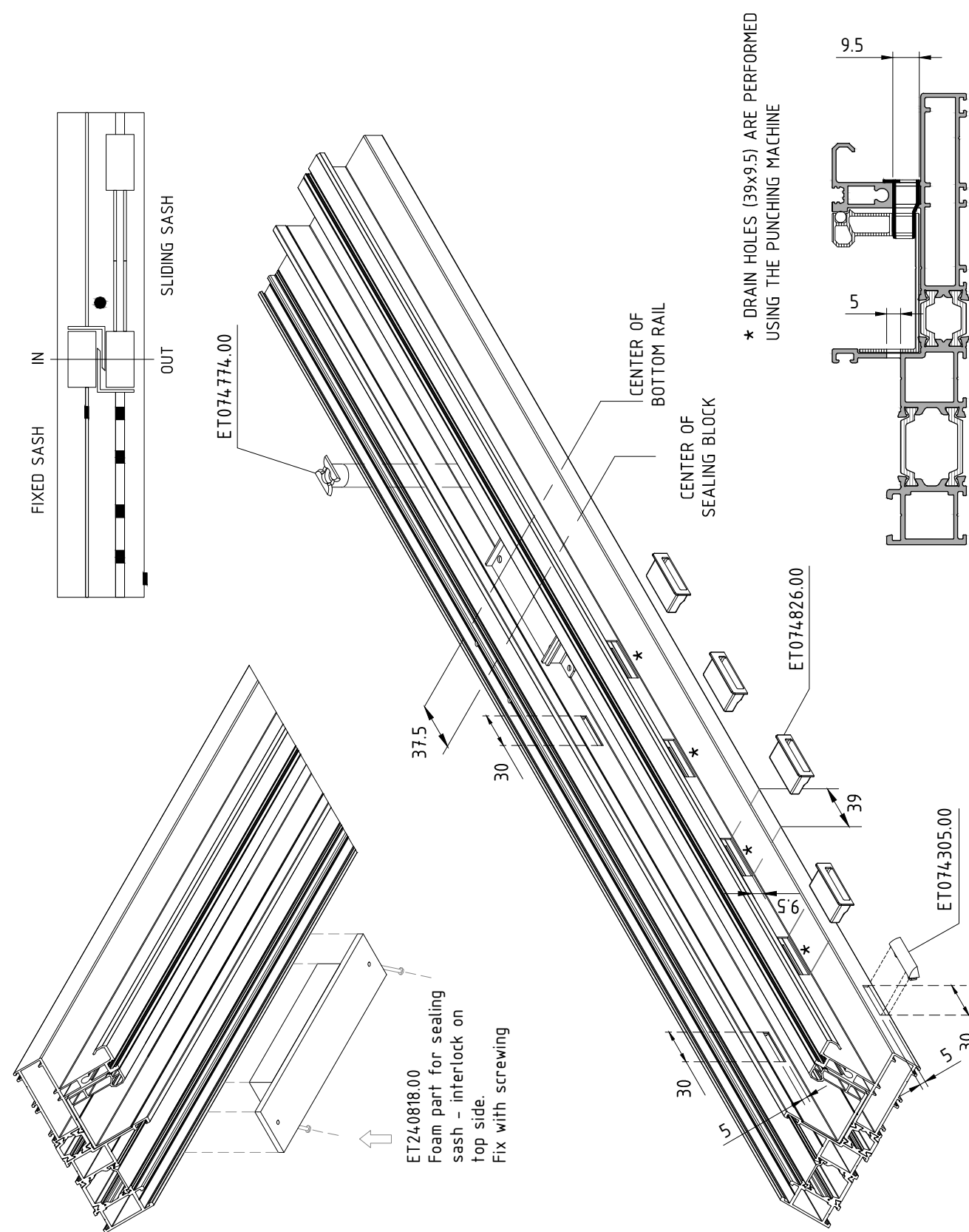

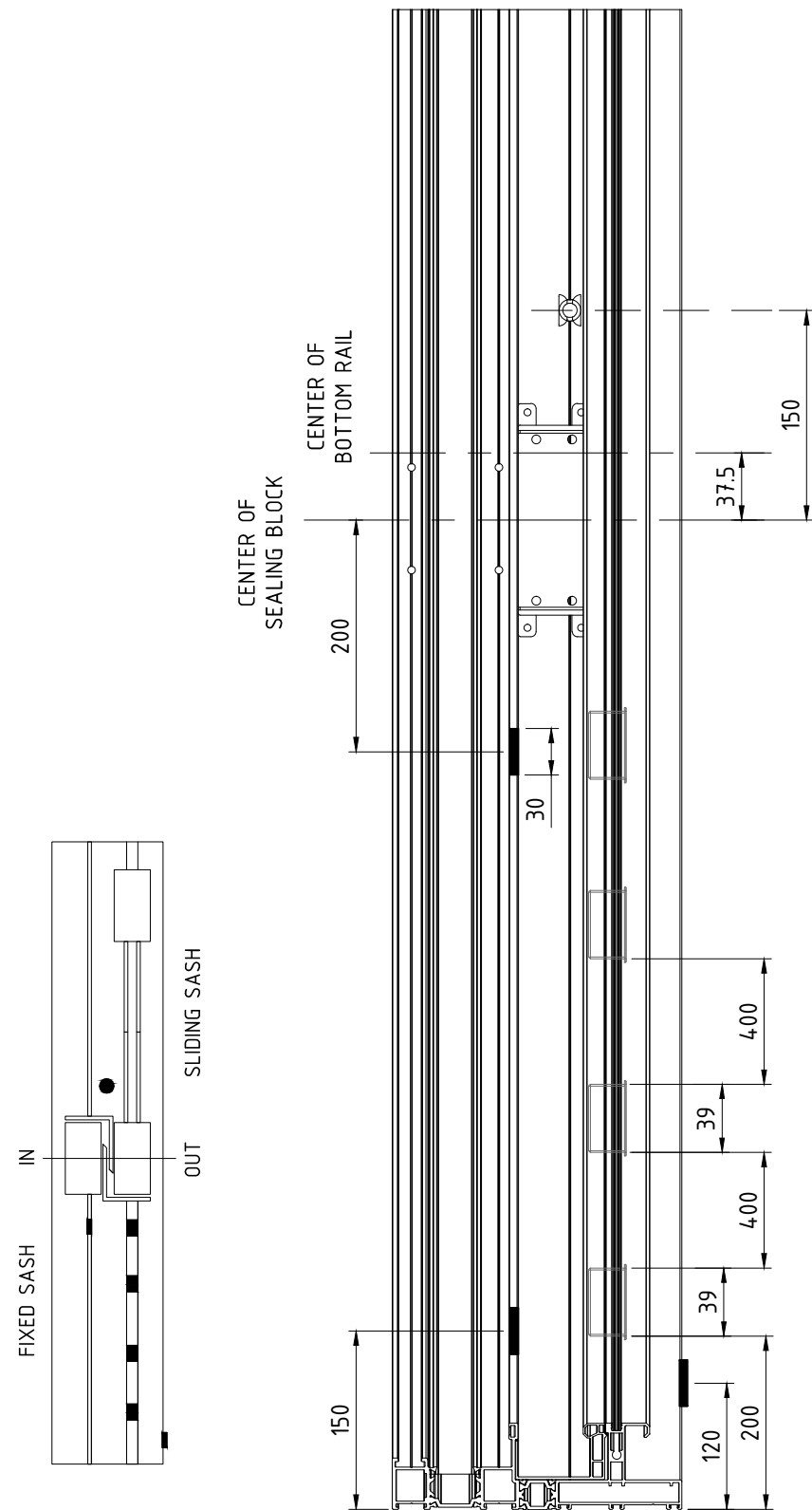

* THE DRAIN HOLE (30x5) IS PERFORMED USING THE PUNCHING MACHINE

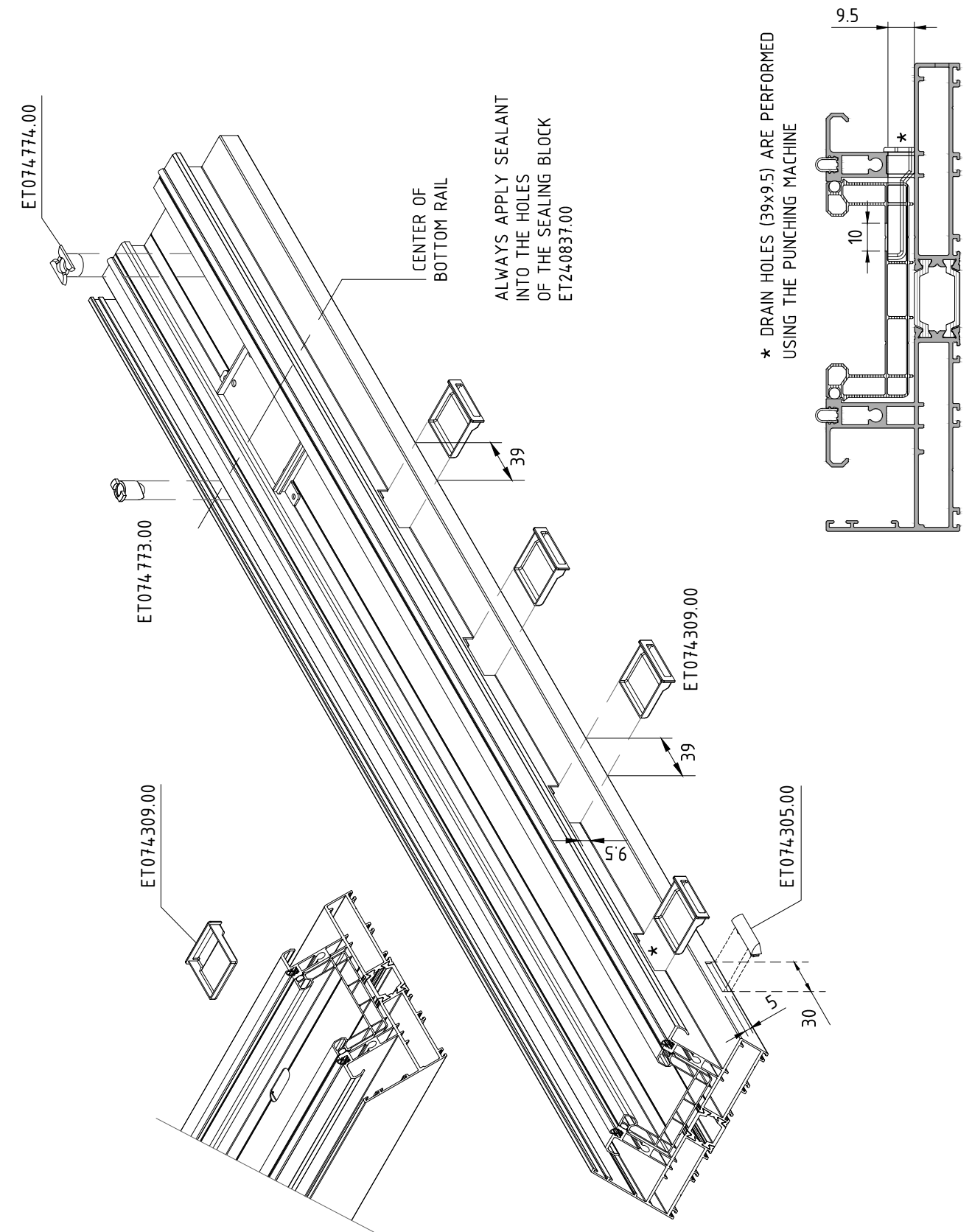
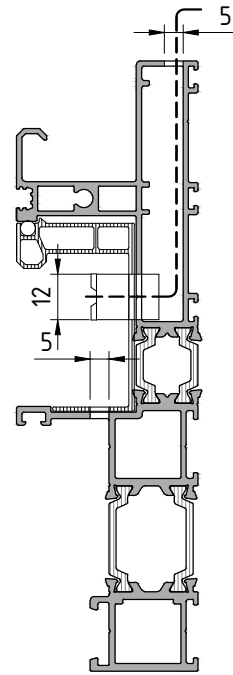

* DRAIN HOLES (30x9.5) ARE PERFORMED USING THE PUNCHING MACHINE

sliding system with thermal break

ES70

MACHINING ON DOUBLE RAIL E6270103 FOR DRAINAGE (REQUIRED FOR HIGH PERFORMANCES)

ES70.M-028

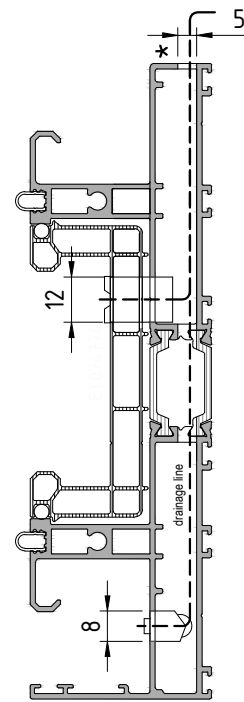
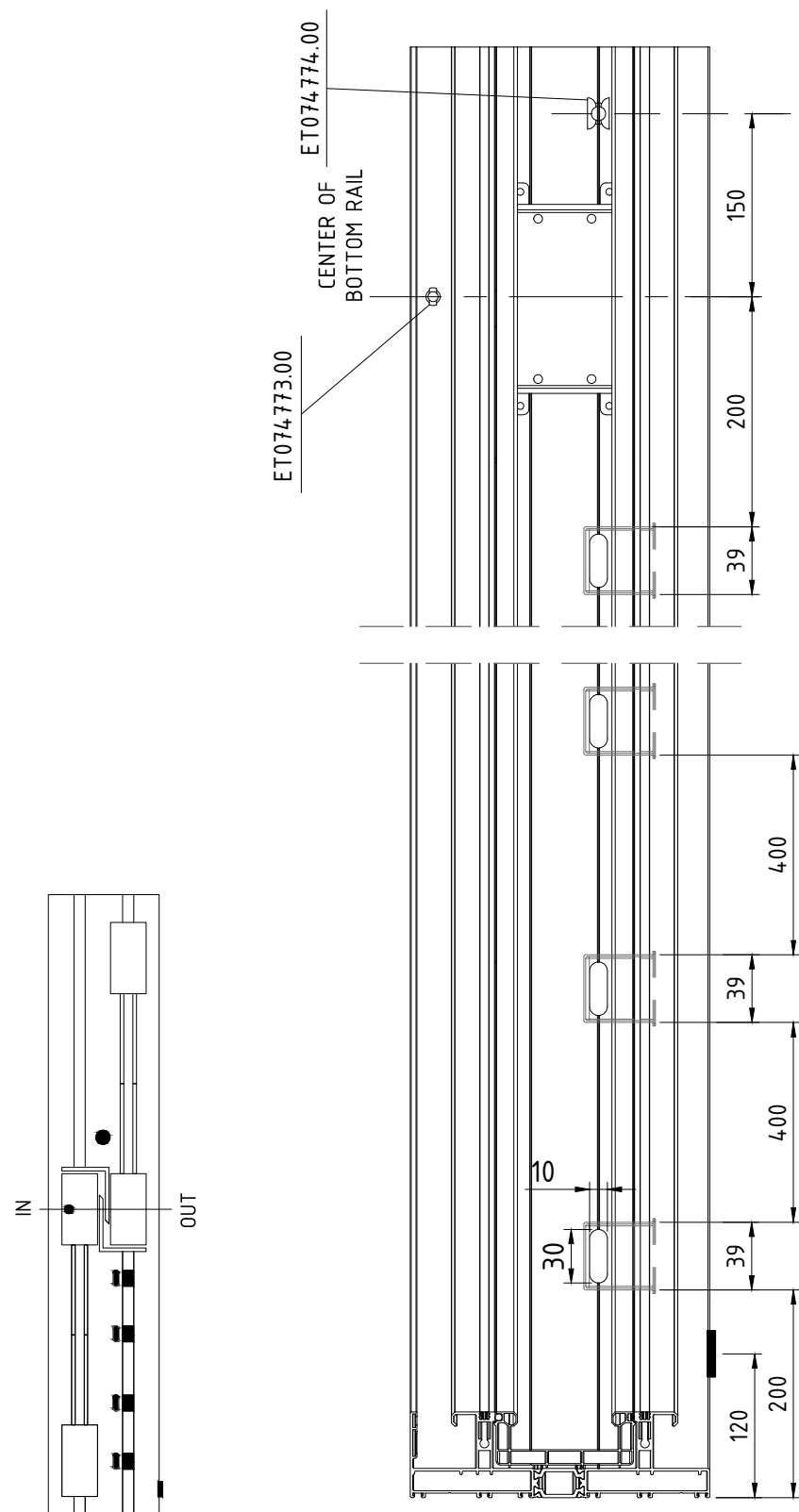

* THE DRAIN HOLE (30x5) IS PERFORMED USING THE PUNCHING MACHINE

sliding system with thermal break

ES70

MACHINING ON FLAT RAIL E6270130 FOR DRAINAGE

ES70.M-029

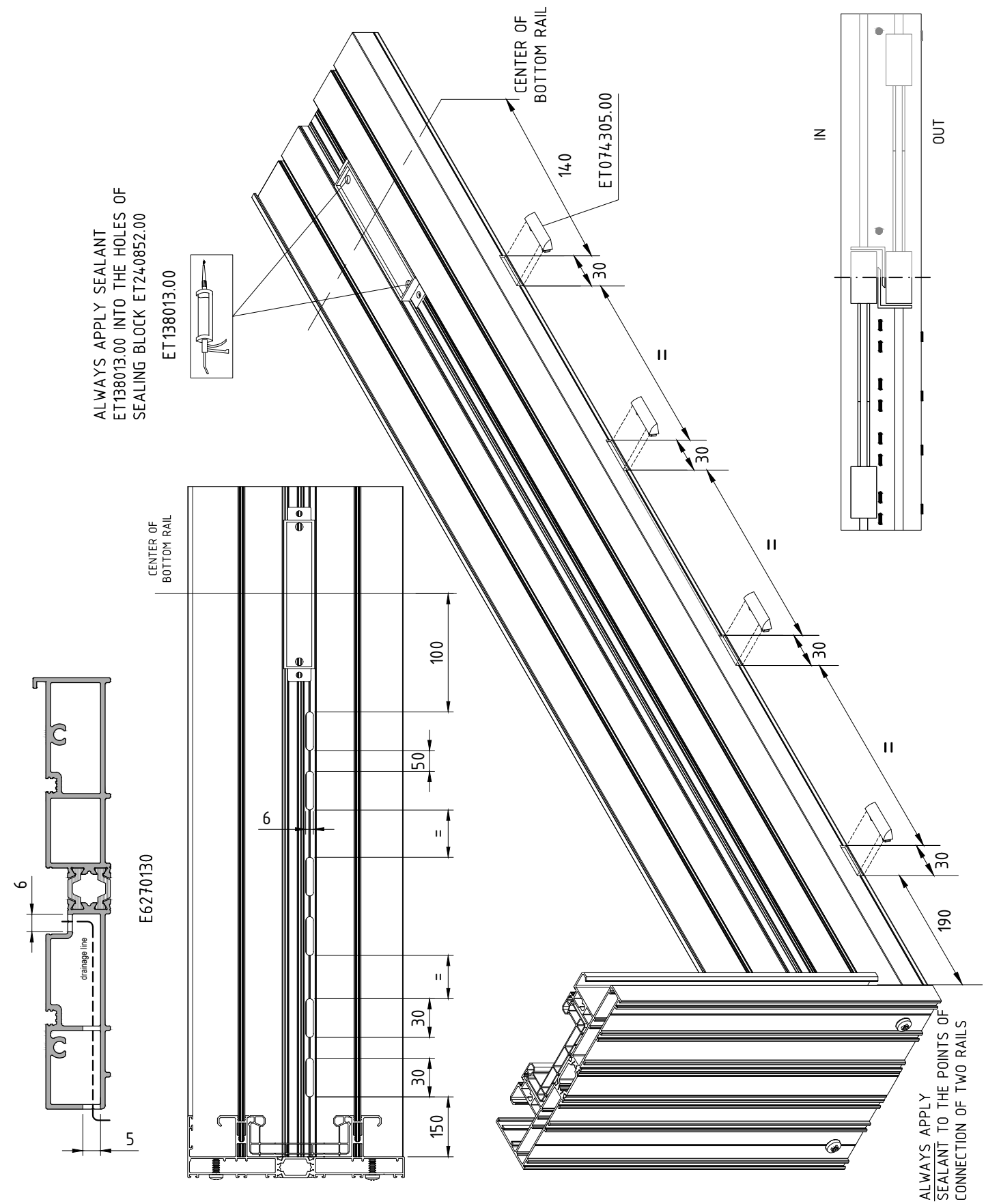

ALWAYS APPLY SEALANT TO THE POINTS OF CONNECTION OF TWO RAILS

sliding system with thermal break

ES70

MACHINING ON FLAT RAIL E6270130 FOR DRAINAGE

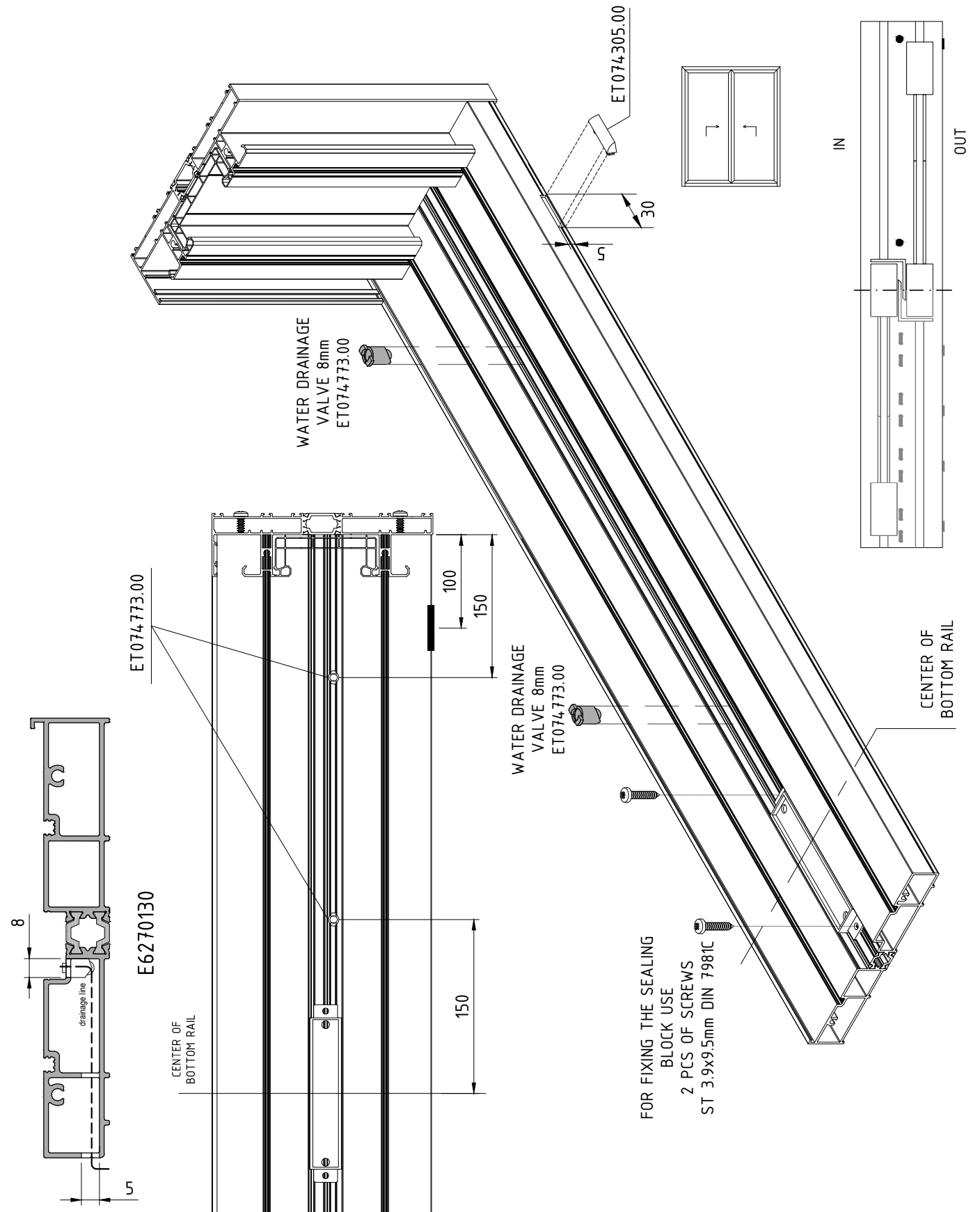

sliding system with thermal break

ES70

DRAINAGE MACHINING FOR TRIPLE & MULTIPLE RAIL

ES70.M-031

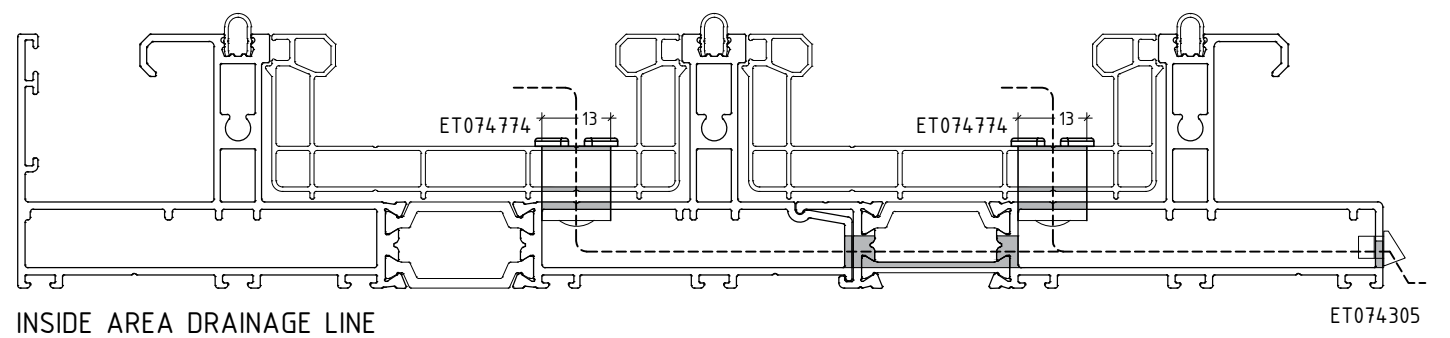
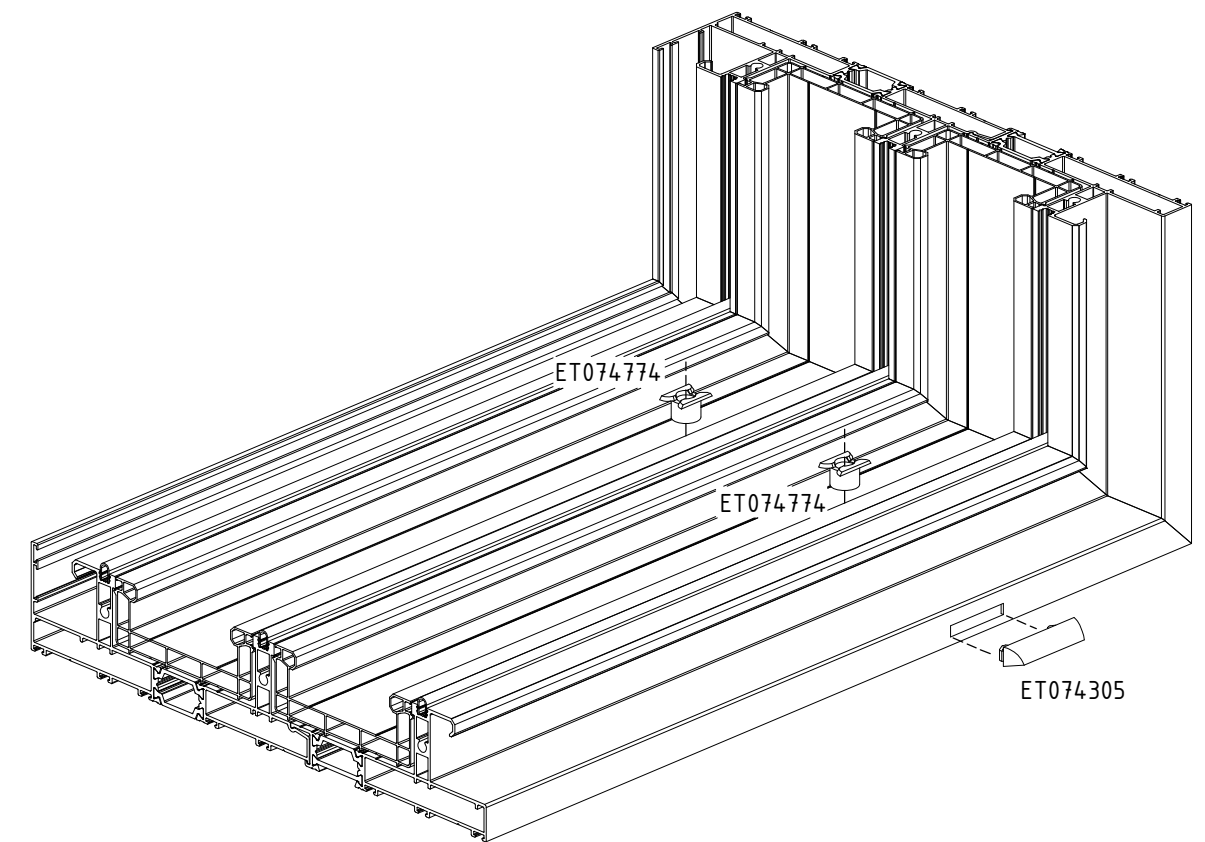
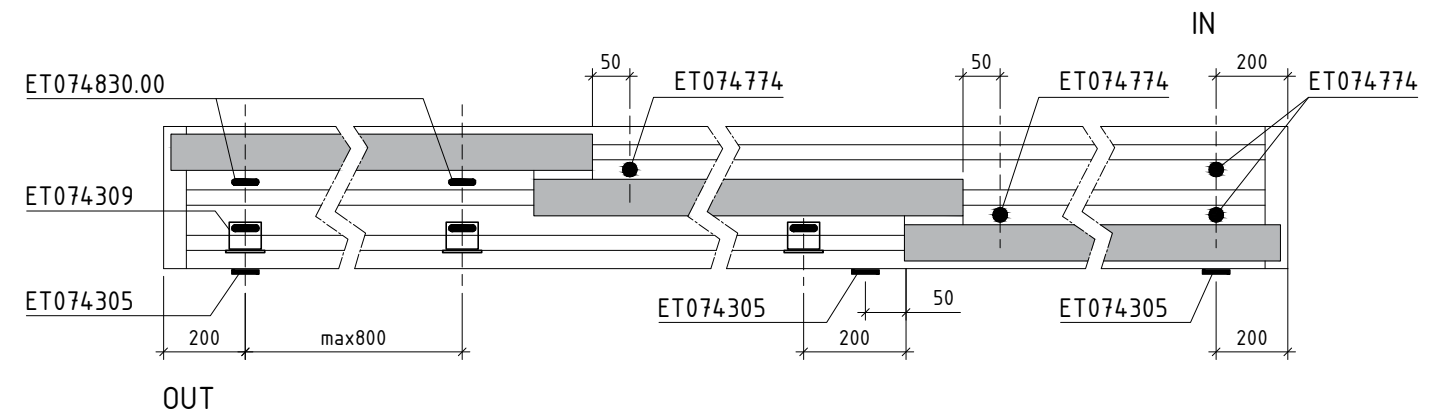

sliding system with thermal break

ES70

DRAINAGE MACHINING FOR TRIPLE & MULTIPLE RAIL

ES70.M-032

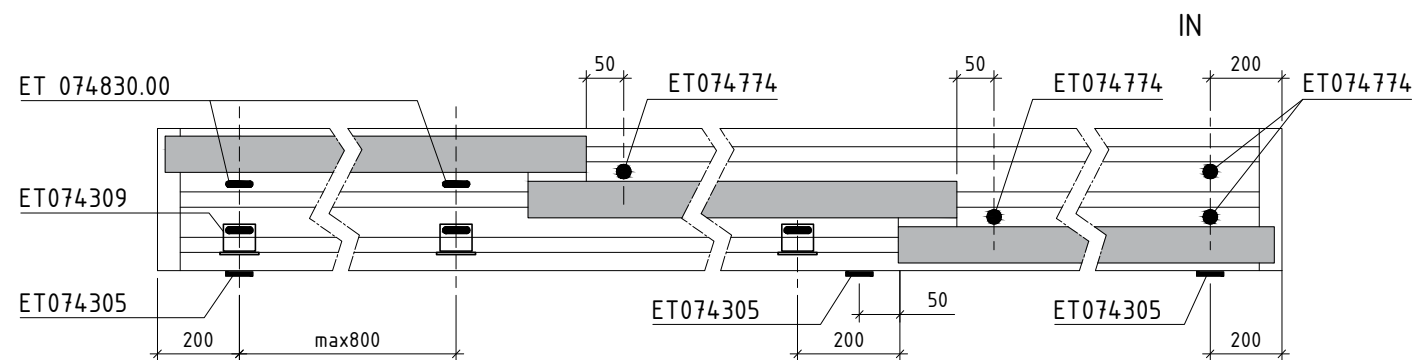

OUT

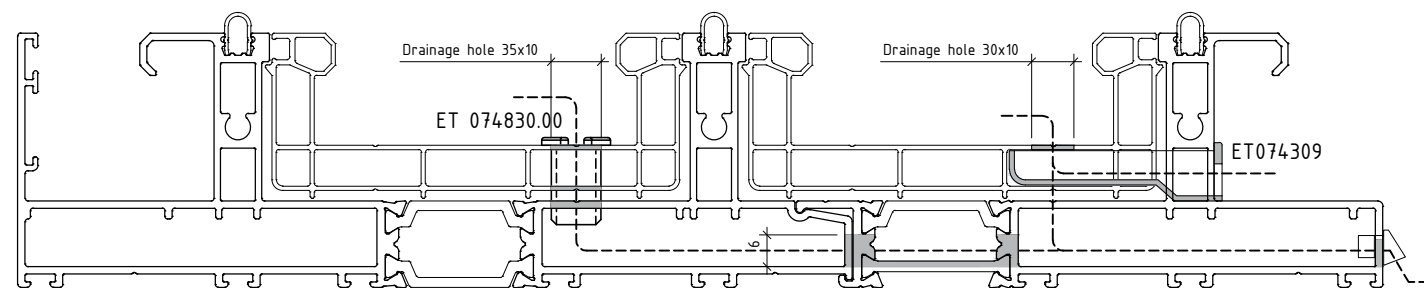
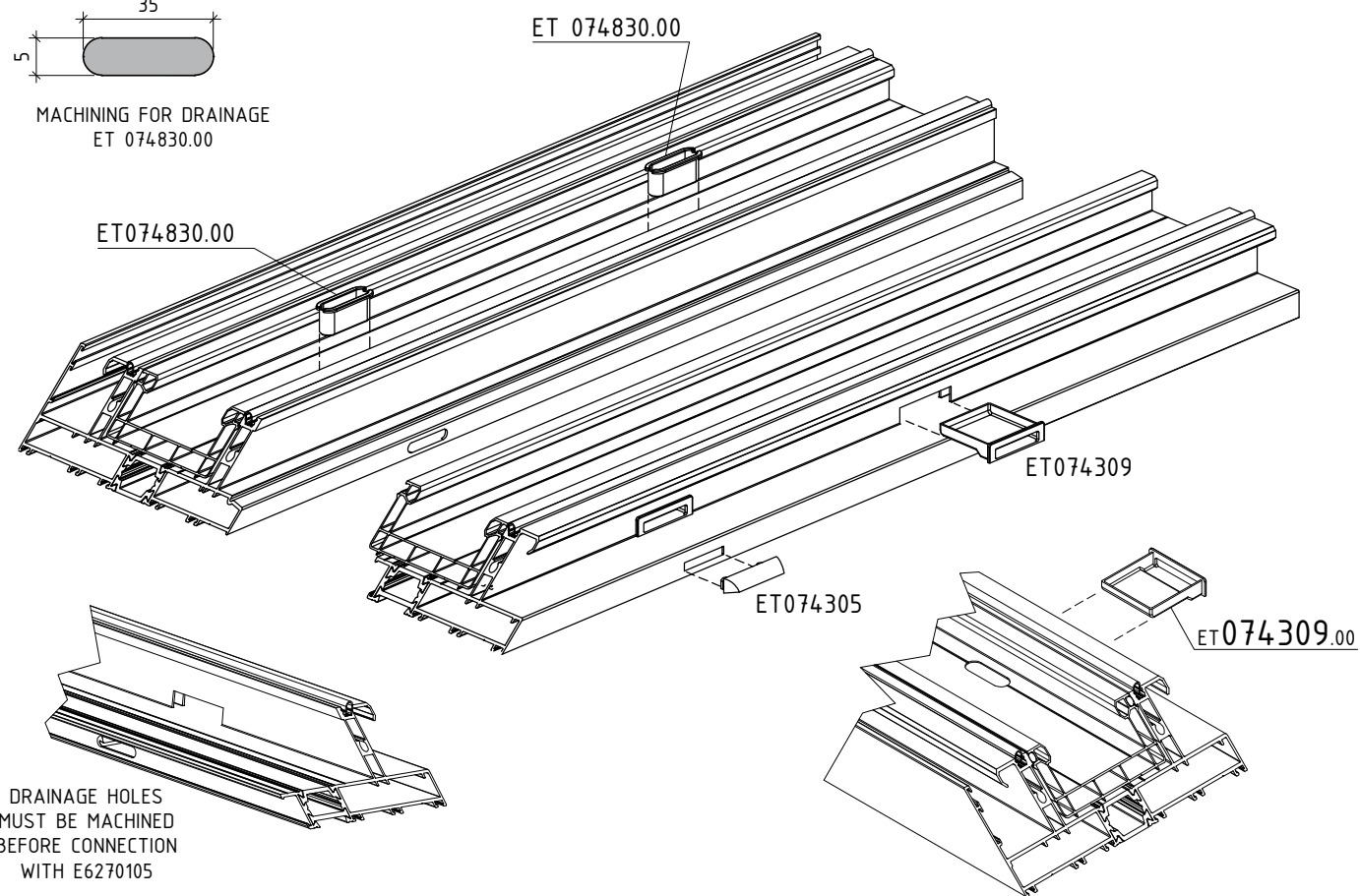
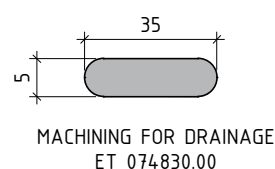

OUTSIDE AREA DRAINAGE LINE

ET074305

sliding system with thermal break

ES70

FIXING ADJOINING PROFILE E6270510

ES70.M-033

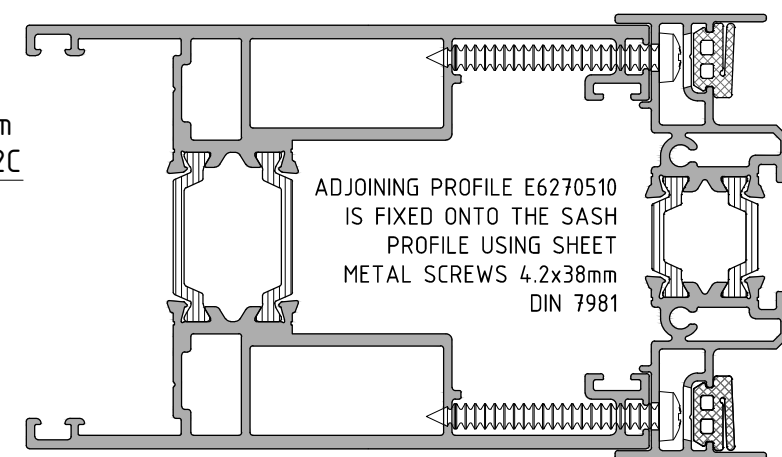
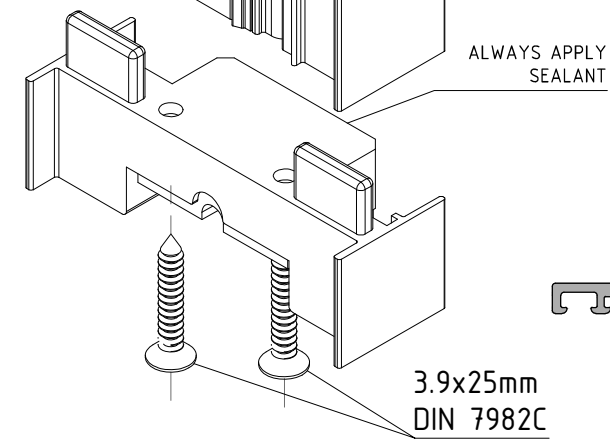
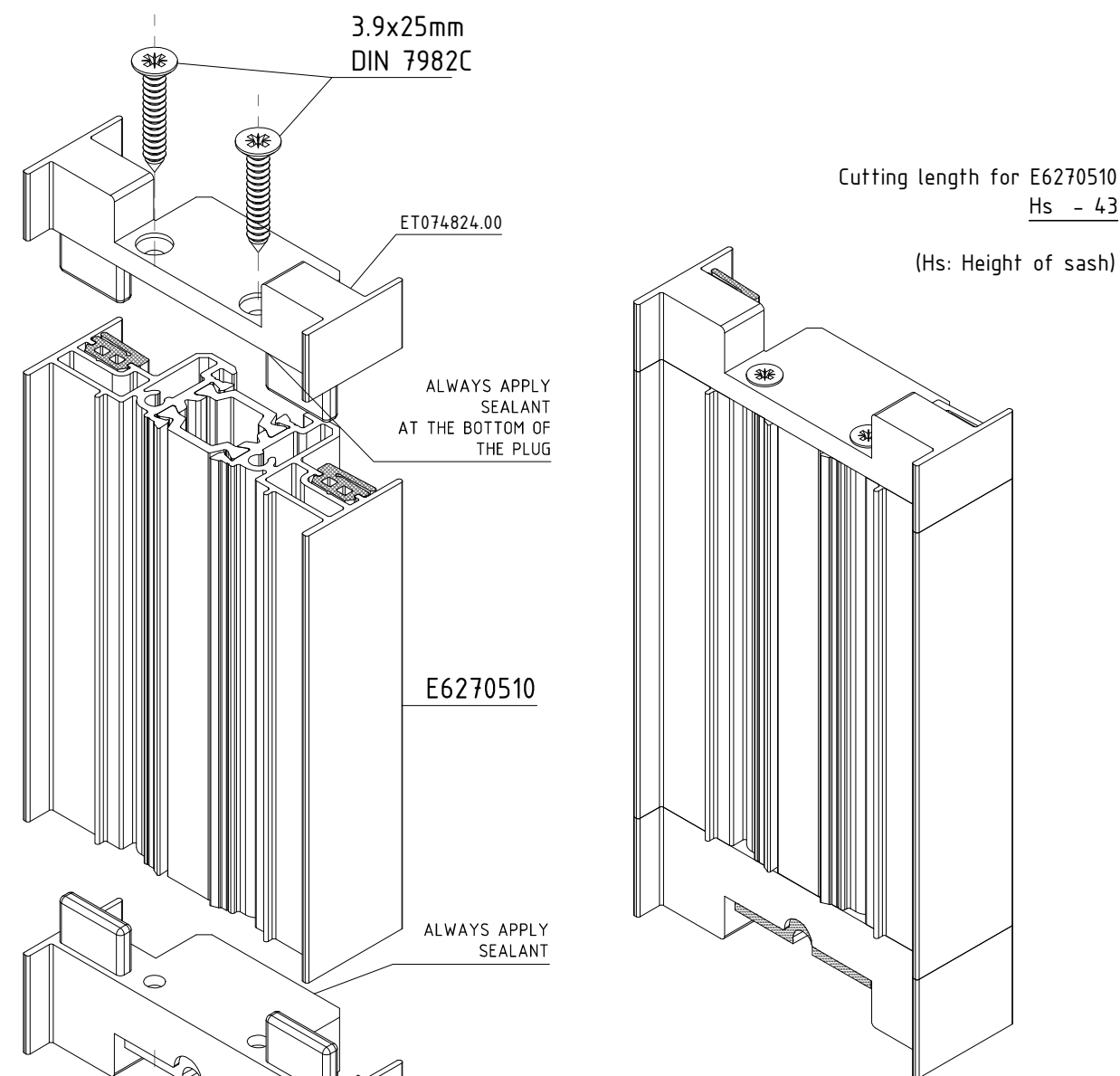

sliding system with thermal break

ES70

PVC INTERLOCK REINFORCEMENT APPLICATION

ES70.M-034

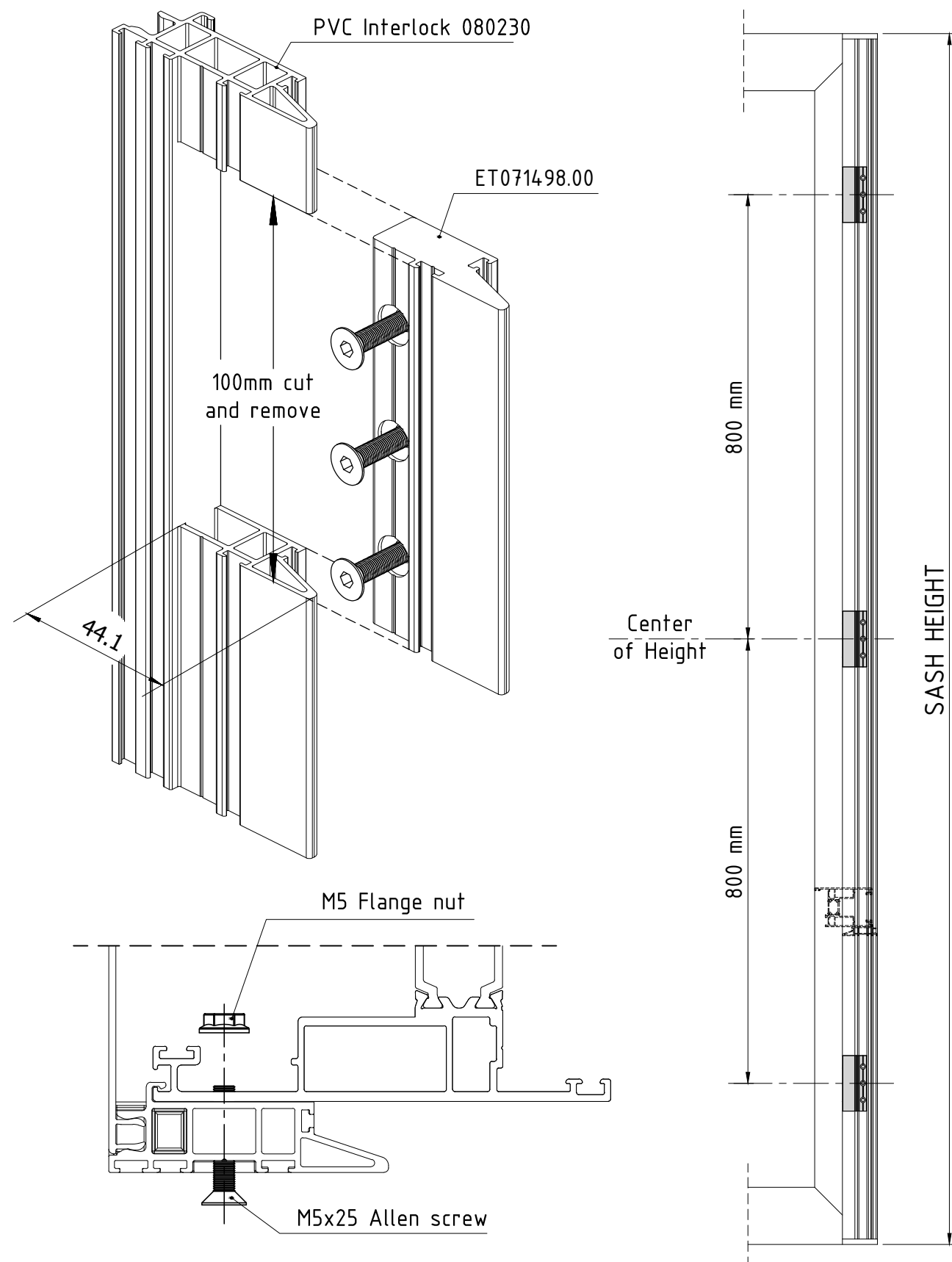

sliding system with thermal break

ES70

FRAME E6270103 ALIGNMENT & ASSEMBLY (FOR 90° CORNER)

ES70.M-035

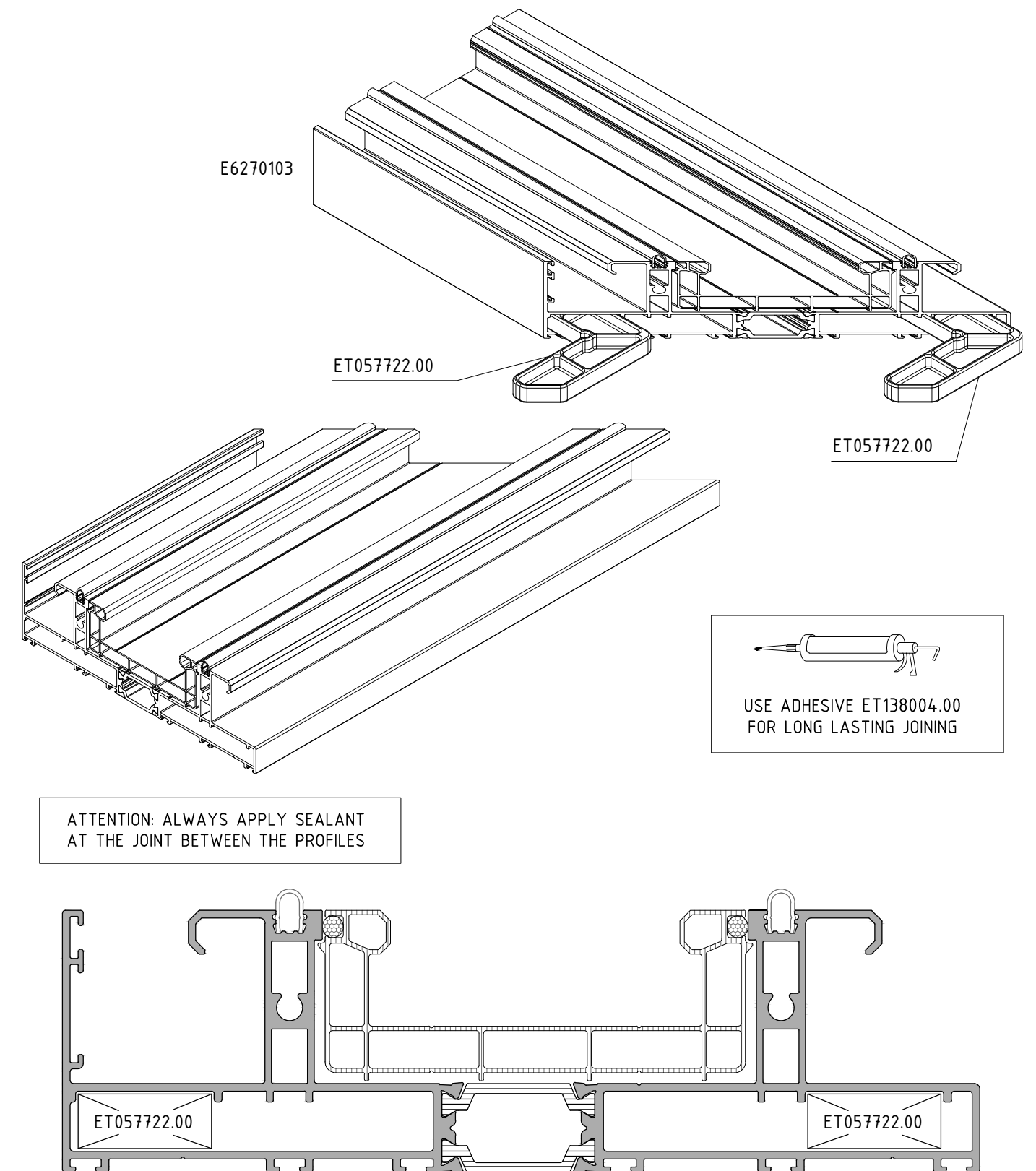

sliding system with thermal break

ES70

MACHINING OF ADJ. PROFILE E6270520 FOR PLASTIC PLUGS INSTALLATION
(FOR 90° CORNER)

ES70.M-036

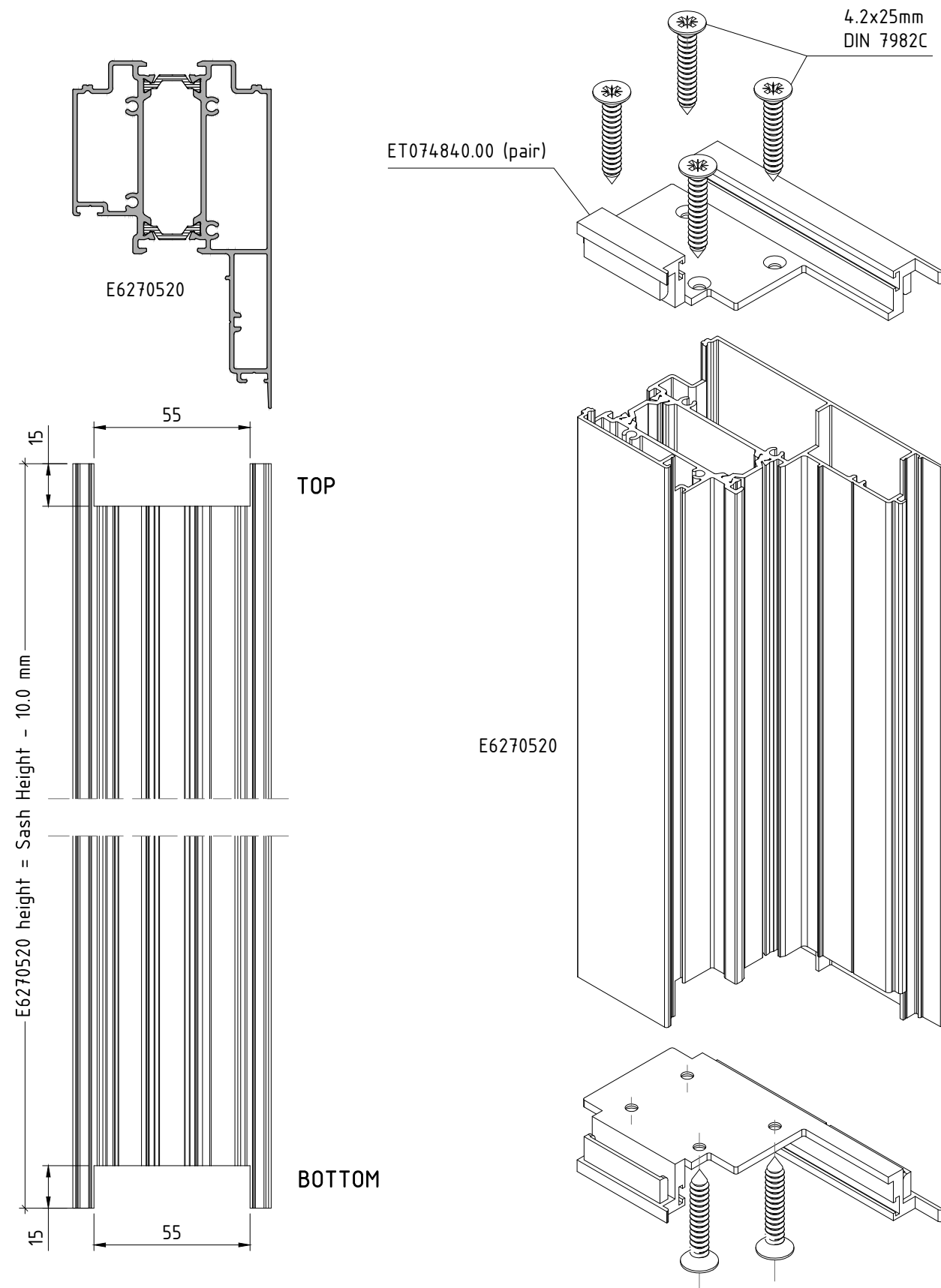

sliding system with thermal break

ES70

INSTALLATION OF E6270520 ANCHOR WITH LATCH ET055053.00 (FOR 90° CORNER)

ES70.M-037

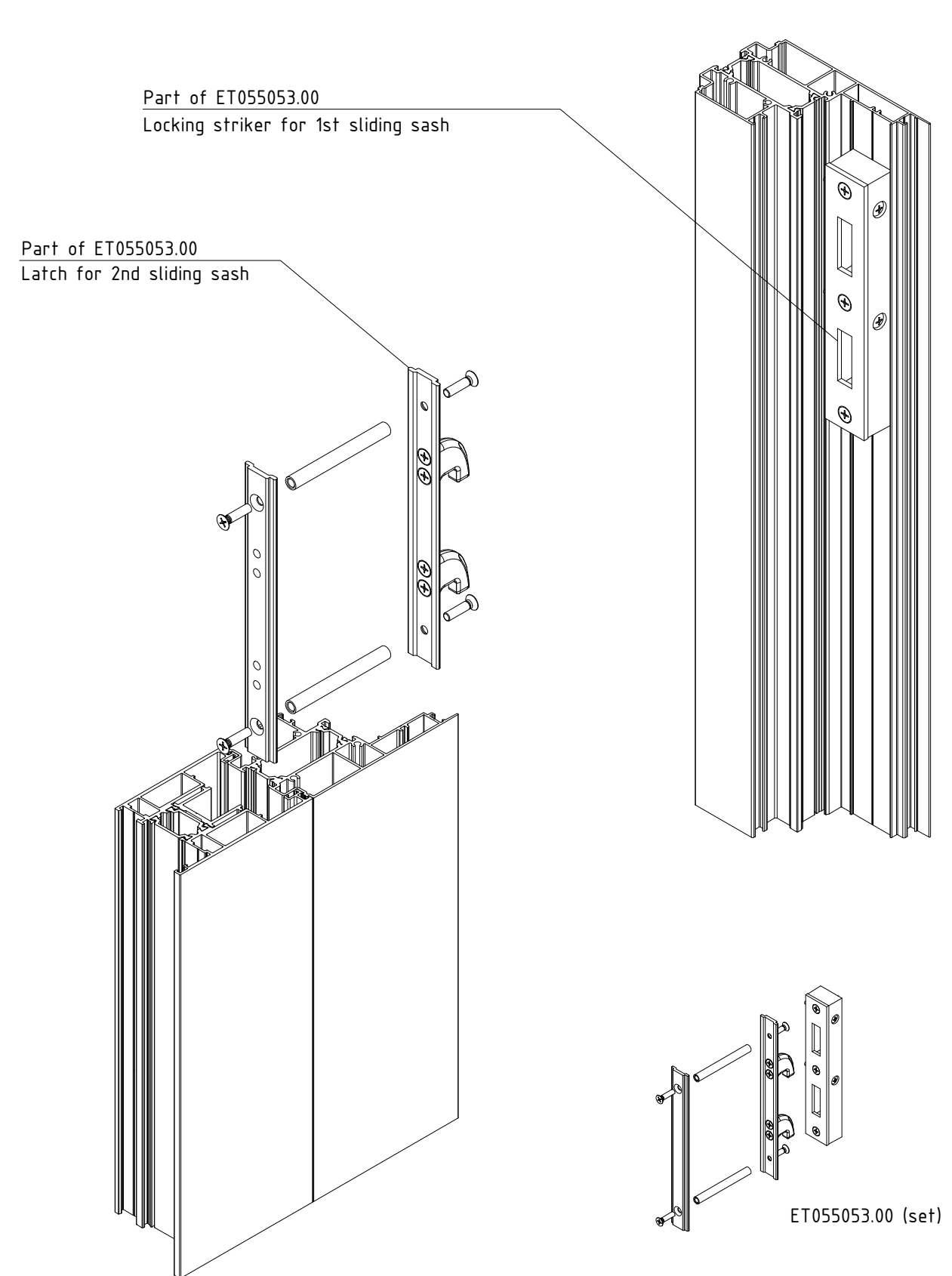

SELECTION OF GASKET & BRUSHES FOR ES70

ES70.M-038

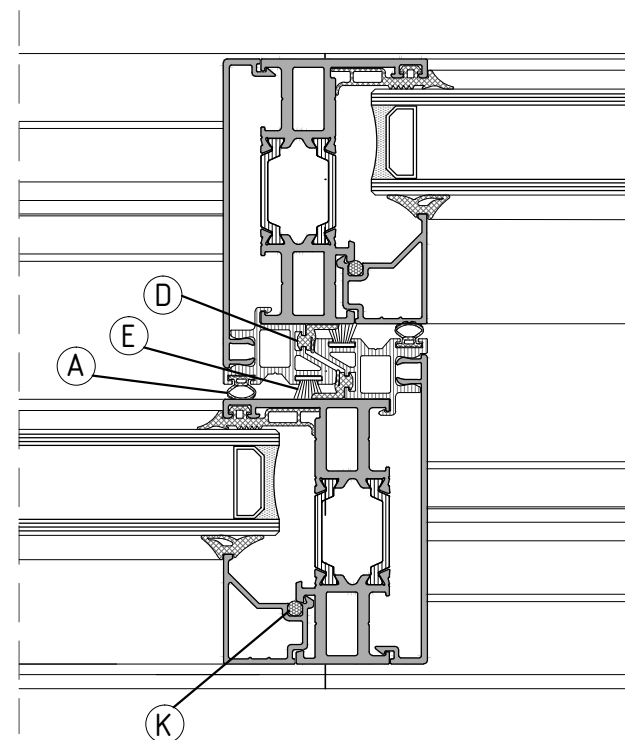
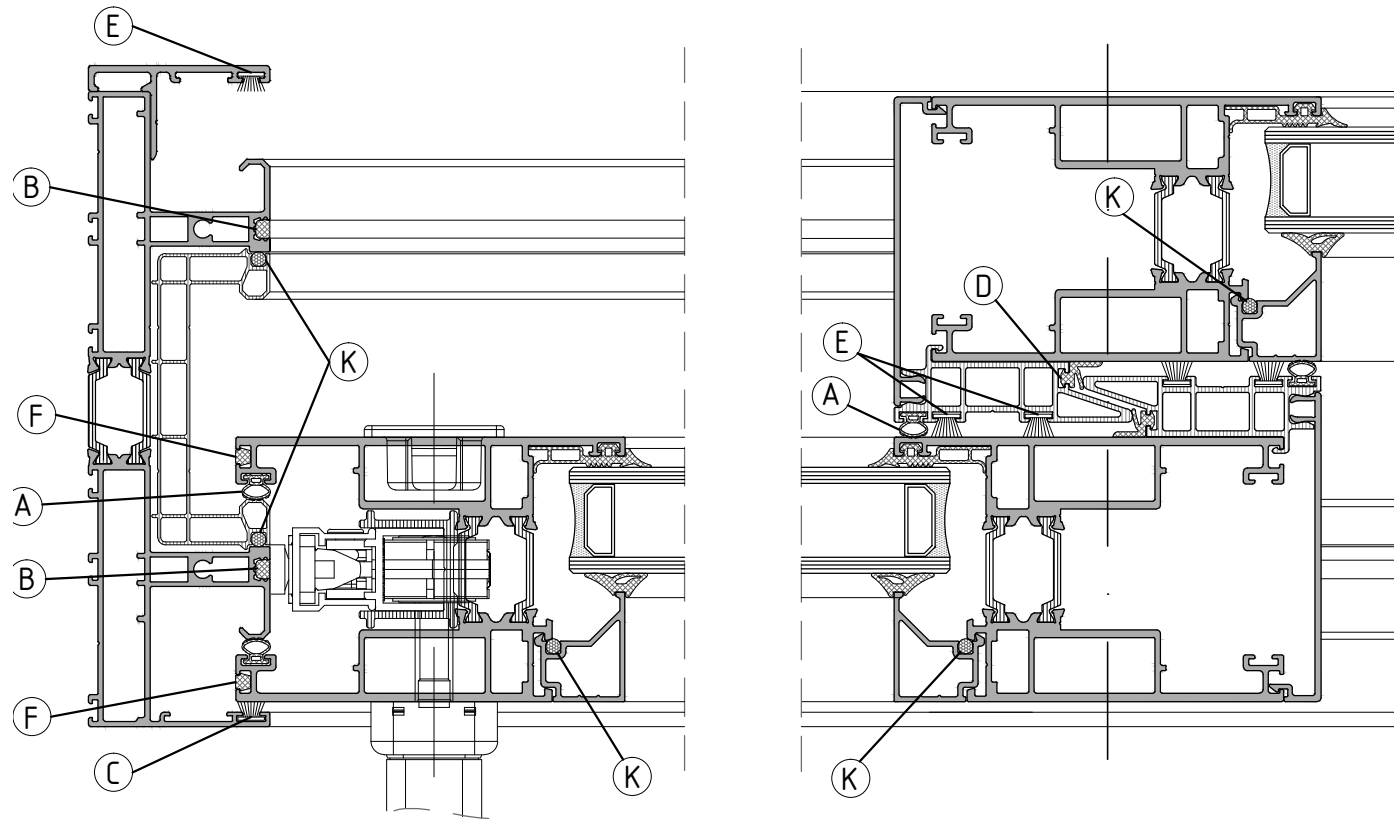

A	ET 130048	
B	ET 130770	
C	ET 135506	6.0mm
D	ET 130173	
E	ET 135508	8.0mm
F	ET 130170	
G	ET 135514	14.0mm
H	ET 130830	
I	ET 130112	
K	ET 130101	

SELECTION OF GASKET & BRUSHES FOR ES70

ES70.M-039

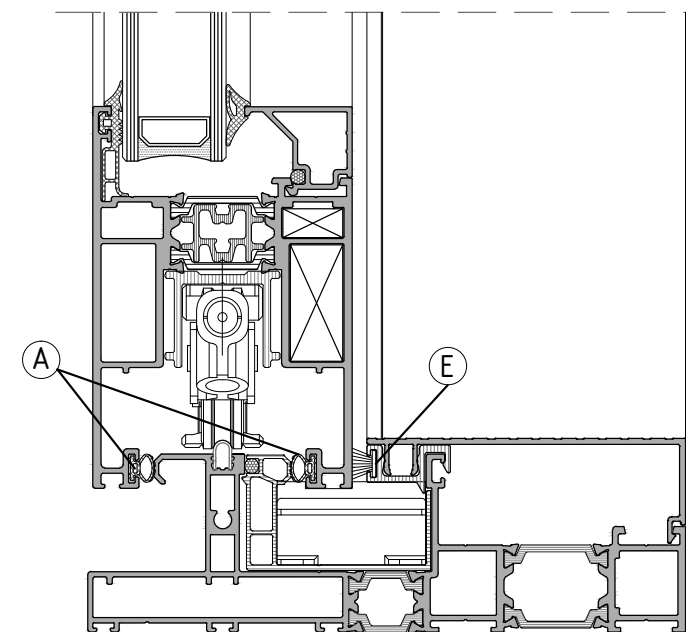
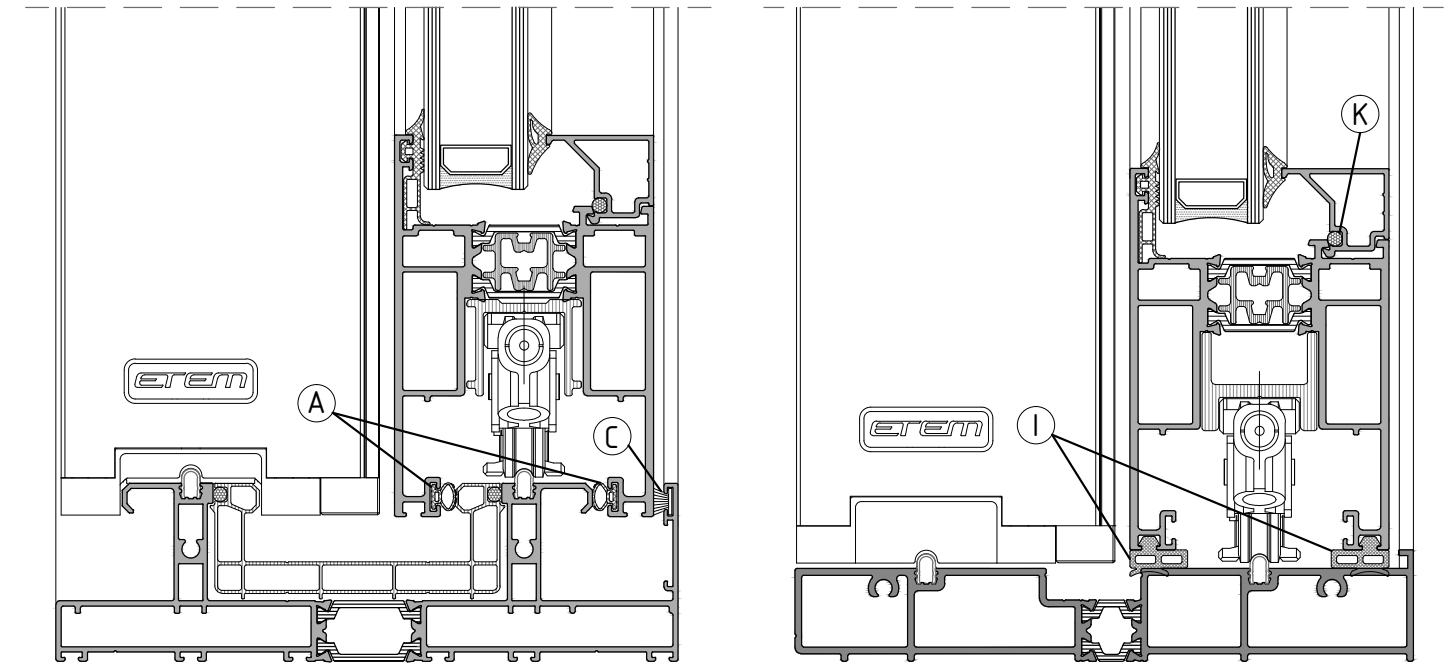

A	ET 130048	
B	ET 130770	
C	ET 135506	6.0mm
D	ET 130173	
E	ET 135508	8.0mm
F	ET 130170	
G	ET 135514	14.0mm
H	ET 130830	
I	ET 130112	
K	ET 130101	

SELECTION OF GASKET & BRUSHES FOR ES70

ES70.M-040

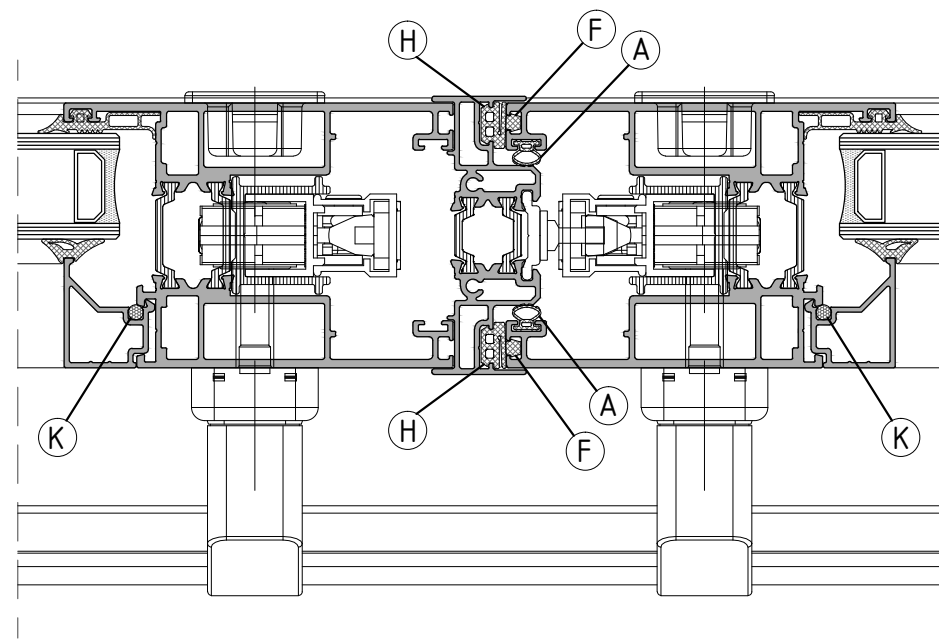
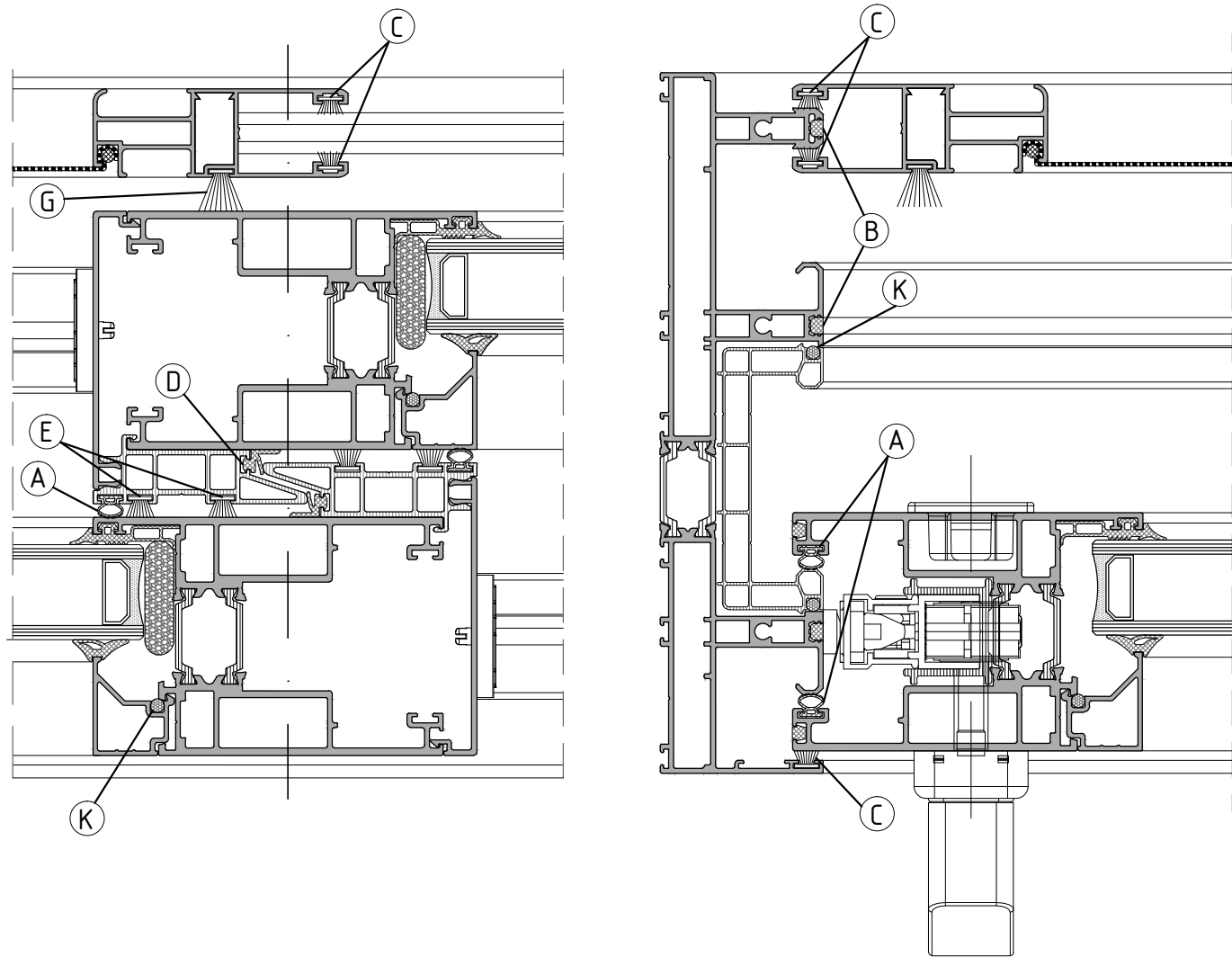

A	ET 130048	
B	ET 130770	
C	ET 135506	
D	ET 130173	
E	ET 135508	
F	ET 130170	
G	ET 135514	
H	ET 130830	
I	ET 130112	
K	ET 130101	

SELECTION OF GASKET & BRUSHES FOR ES70

ES70.M-041

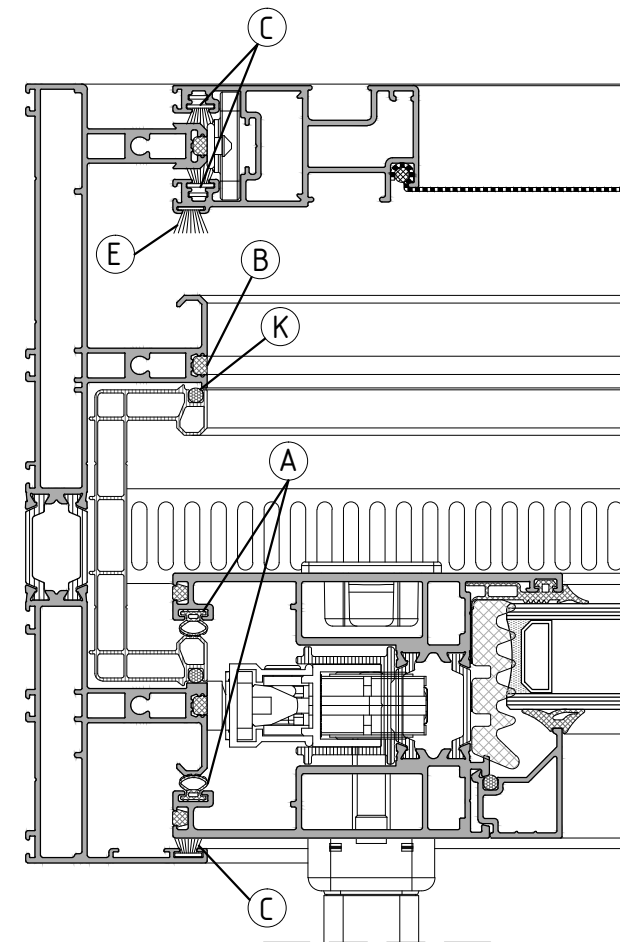
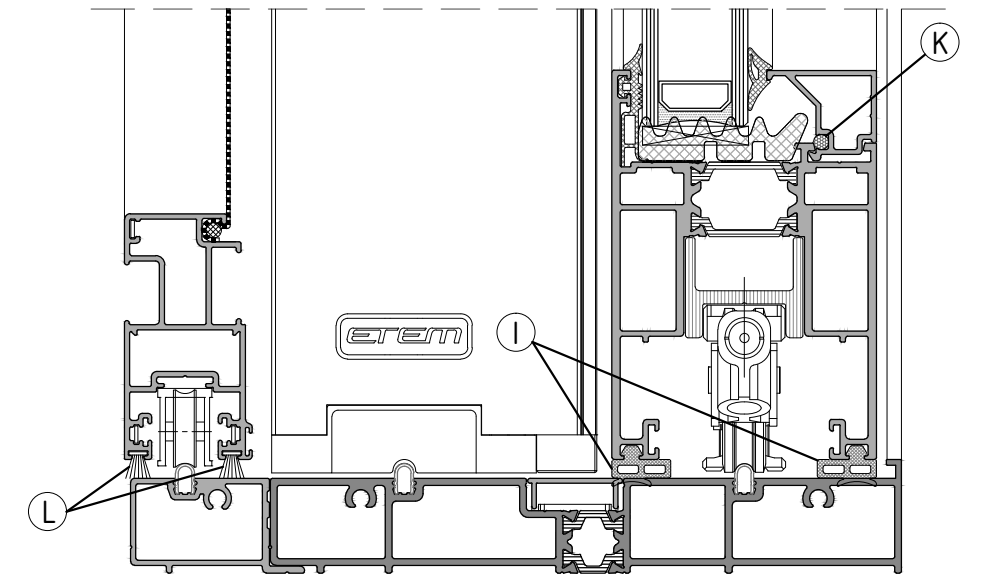

A	ET 130048	
B	ET 130770	
C	ET 135506	
D	ET 130173	
E	ET 135508	
F	ET 130170	
G	ET 135514	
H	ET 130830	
I	ET 130112	
K	ET 130101	
L	ET 135588	

ACCESSORIES

IMAGES / DESCRIPTIONS

sliding system with thermal break

ES70

code/description	package/pcs	colour
ET 130205.00		●

Glazing EPDM gasket
press-in 5.0 mm



ET 130206.00		●
--------------	--	---

Glazing EPDM gasket
press-in 6.0 mm



ET 130207.00		●
--------------	--	---

Glazing EPDM gasket
press-in 7.0 mm



ET 130208.00		●
--------------	--	---

Glazing EPDM gasket
press-in 8.0 mm



sliding system with thermal break

ES70

code/description	package/pcs	colour
ET 130407.00		●

Glazing EPDM gasket
press-in 5.0 mm

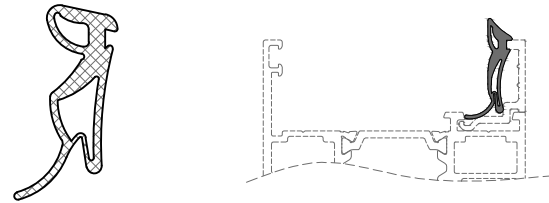

ET 130402.00		●
--------------	--	---

Elongated glazing EPDM
gasket 3.0mm

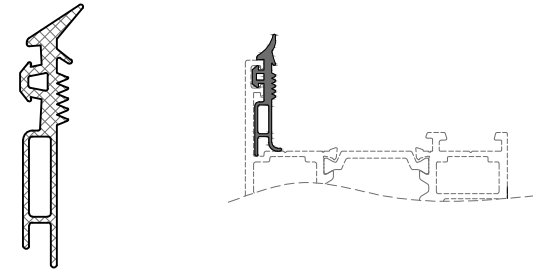

ET 130048.00		●
--------------	--	---

Frame gasket for sash

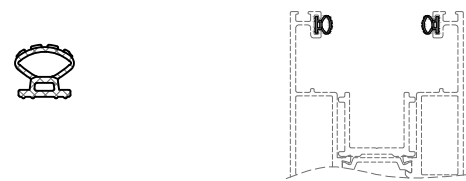

ET 130112.00		●
--------------	--	---

Sash gasket for low rail

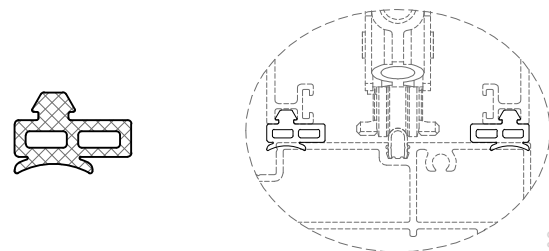

ES70-A-02

sliding system with thermal break

ES70

code/description	package/pcs	colour
ET 130170.00		●

Groove cover gasket for
ES6270201

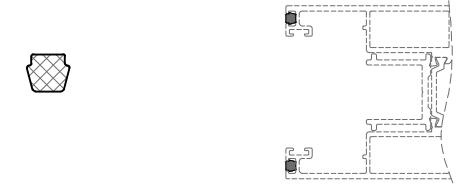

ET 130173.00		●
--------------	--	---

Stopper gasket for interlock
PVC ES70

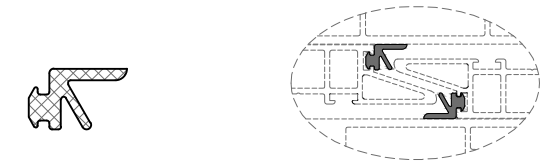

ET 130770.00		●
--------------	--	---

EPDM gasket for rail groove
covering

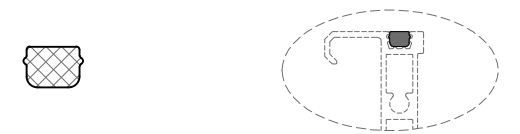

ET 130830.00		●
--------------	--	---

EPDM gasket for adjoining
profile

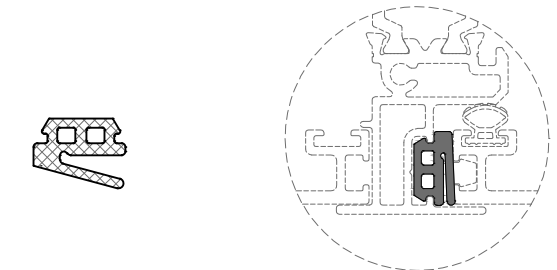

ES70-A-03

sliding system with thermal break

ES70

code/description	package/pcs	colour
ET 130831.00		●

Wall-joining EPDM external gasket for straight fixed frame

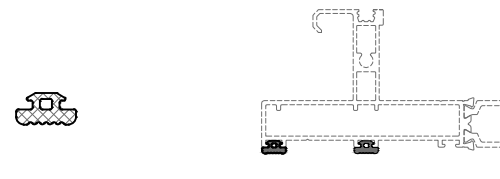

ET 080751.00		●
--------------	--	---

Additional insulator for sash

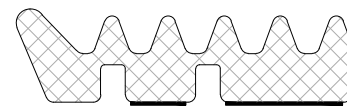

ET 130101.00		●
--------------	--	---

EPDM foam gasket ϕ 4mm

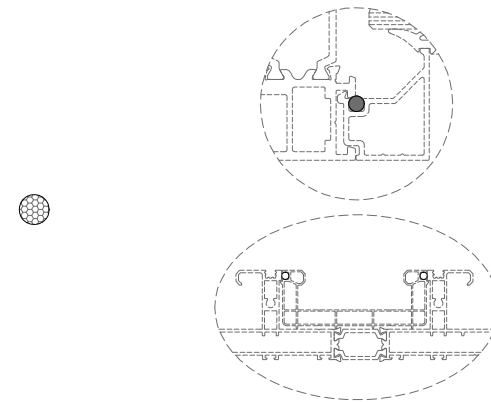

ET 082201.00		
--------------	--	--

Stainless steel rail (E36, E50, ES70)

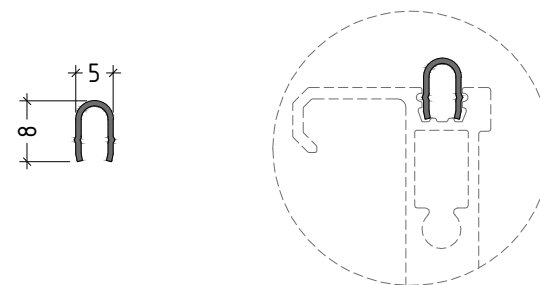

ES70.A-04

sliding system with thermal break

ES70

code/description	package/pcs	colour
ET 080213.00		●

Plastic profile (PVC) for sash 6070201

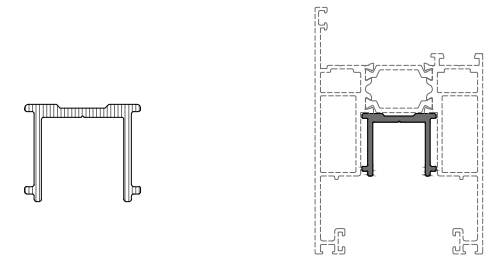

ET 080229.00		●
--------------	--	---

Plastic profile (PVC) for rails

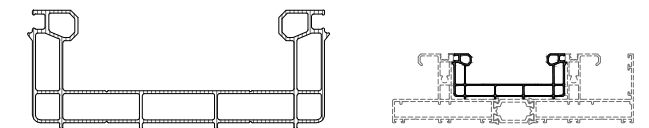

ET 080232.00		●
--------------	--	---

Plastic profile (PVC) for hotel type rail

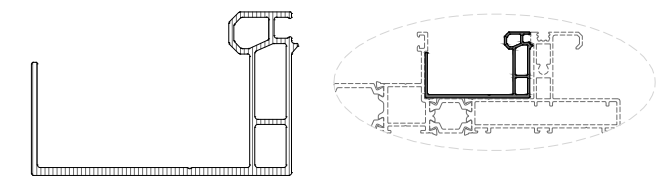

ET 080230.00		●
--------------	--	---

Plastic spacer for interlock for ES70

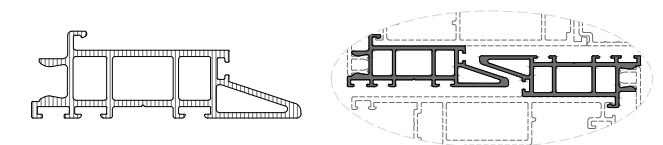

ES70.A-05

sliding system with thermal break

ES70

code/description	package/pcs	colour
ET 080231.00		●

Glazing sash internal PVC

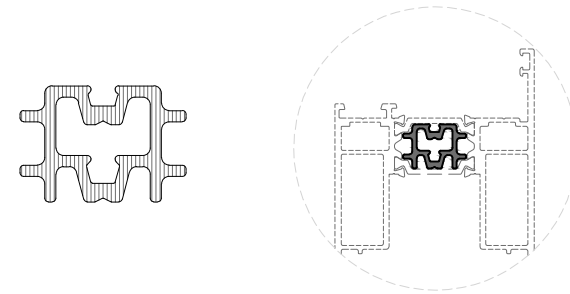

ET 080233.00		●
--------------	--	---

Plastic profile (PVC) for slim interlock

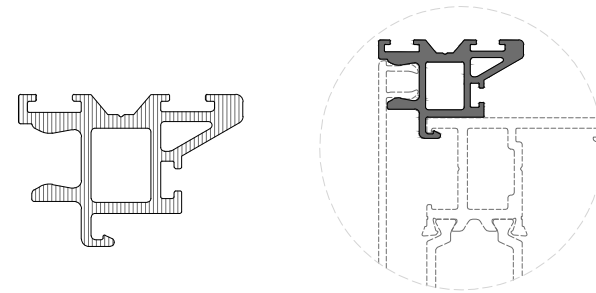

ET 080234.00		●
--------------	--	---

Plastic profile (PVC) for hotel type rail cover



ET 135406.01		●
ET 135406.02		●
ET 135406.04		○

Pile weatherseal
4P 6.0mm

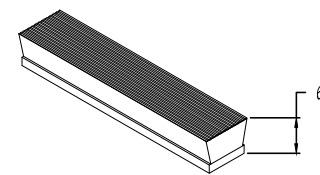

ES70.A-06

sliding system with thermal break

ES70

code/description	package/pcs	colour
ET 135408.01		●
ET 135408.02		●
ET 135408.04		○

Pile weatherseal
4P 8.0mm

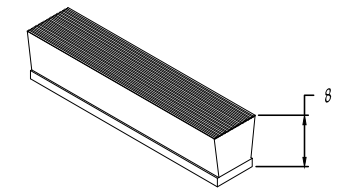

ET 135414.01		●
ET 135414.02		●
ET 135414.04		○

Pile weatherseal
4P 14.0 mm

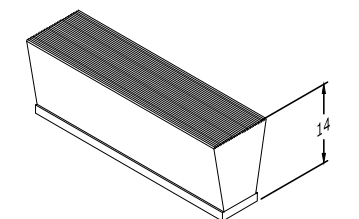

ET 135506.01		●
ET 135506.02		●
ET 135506.04		○

Pile weatherseal
FP 6.0mm

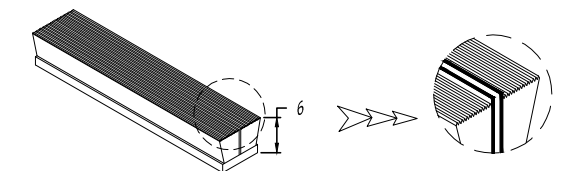

ET 135508.01		●
ET 135508.02		●
ET 135508.04		○

Pile weatherseal
FP 8.0mm

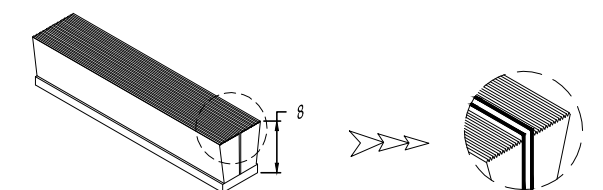

ES70.A-07

sliding system with thermal break

ES70

code/description	package/pcs	colour
ET 135514.01		●
ET 135514.02		●
ET 135514.04		○

Pile weatherseal
FP 14.0 mm

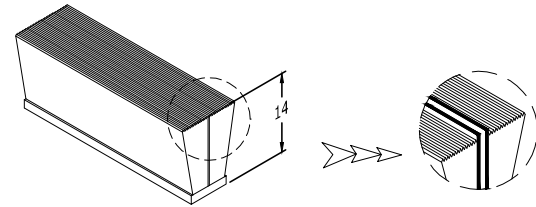

ET 135588.02		●
--------------	--	---

Pile weatherseal with
base 4.8 mm, 4P 8 mm
for screen sash E6270220

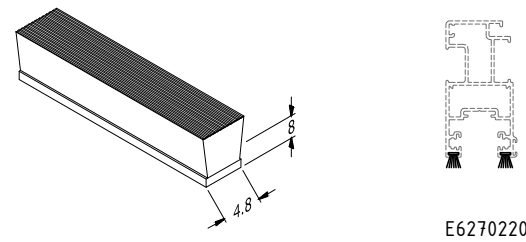

ET 080701.00		
--------------	--	--

Additional insulator 22x9mm
for frames

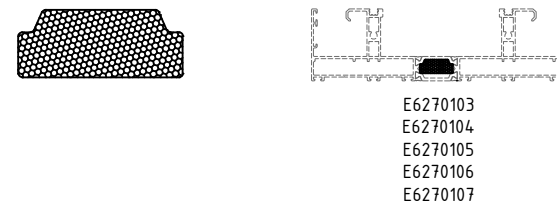

ET 080702.00		
--------------	--	--

Additional insulator
16.5x26.6mm for sash wings



ES70.A-08

sliding system with thermal break

ES70

code/description	package/pcs	colour
ET 080703.00		

Additional insulator
26.4x61mm for hotel mullion

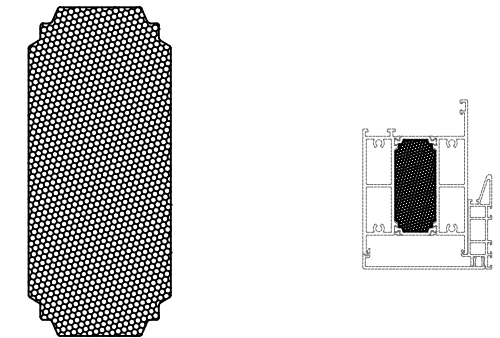

ET 080705.00		
--------------	--	--

Additional insulator 14x12 mm
for hotel frame & adjoining
profile

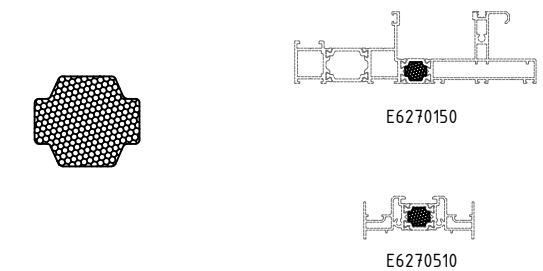

ET 080706.00		
--------------	--	--

Additional insulator
59x66.3mm for sash interlock
area

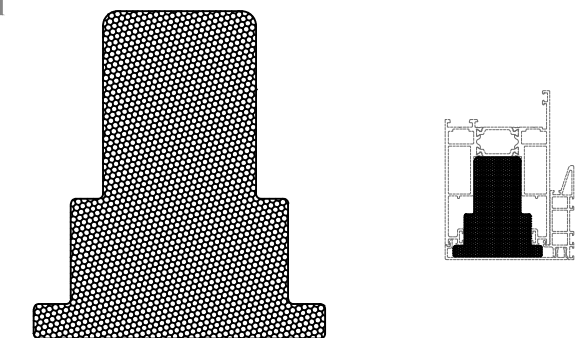

ET 080707.00		
--------------	--	--

Additional insulator
60x20mm for hotel mullion

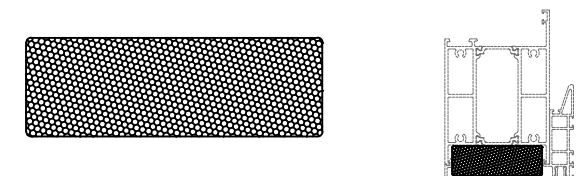

ES70.A-09

sliding system with thermal break

ES70

code/description	package/pcs	colour
ET 080711.00		

Additional insulator
22x15.4mm for frames &
sash

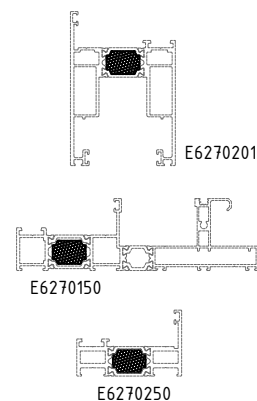
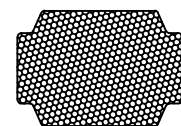

ET 080708.00		
--------------	--	--

Additional insulator
65.7x10.2mm for frames

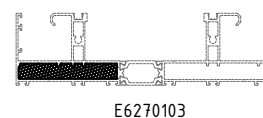

ATTENTION: APPLICABLE ONLY
IN CASE THAT Ø8mm VALVE
ET074773.00 IS NOT USED

ET 080709.00		
--------------	--	--

Additional insulator
44x45.5mm for sash

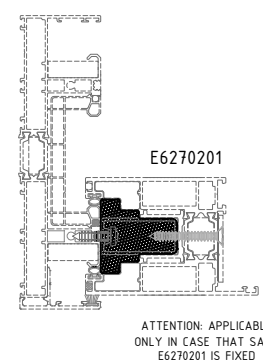
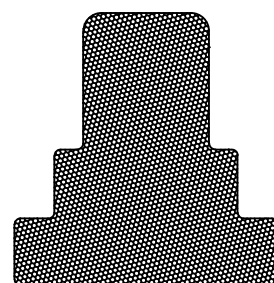

ATTENTION: APPLICABLE
ONLY IN CASE THAT SASH
E6270201 IS FIXED

ET 240711.00		
--------------	--	--

EPDM foam insert for frame
cavities (15mm thick.)

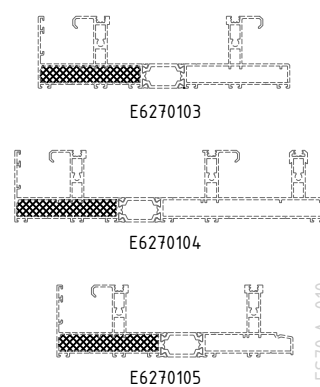

ES70 A-010

sliding system with thermal break

ES70

code/description	package/pcs	colour
ET 240712.00		

EPDM foam insert for frame
cavities (15mm thick.)

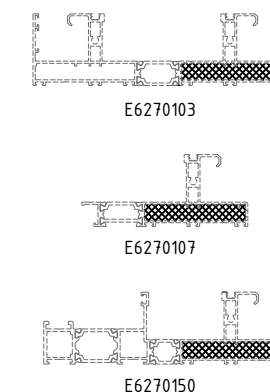

ET 240713.00		
--------------	--	--

EPDM foam insert for frame
cavities (15mm thick.)

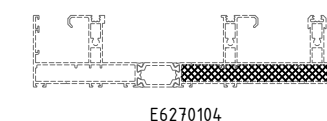

ET 240714.00		
--------------	--	--

EPDM foam insert for frame
cavities (15mm thick.)

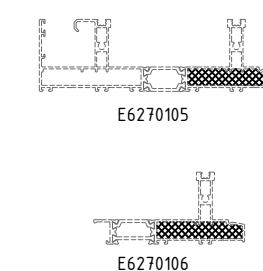

ET 240715.00		
--------------	--	--

EPDM foam insert for frame
cavities (15mm thick.)

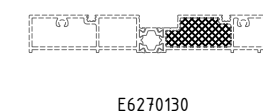

sliding system with thermal break

ES70

code/description	package/pcs	colour
ET 240716.00		

EPDM foam insert for frame cavities (15mm thick.)



ET 240717.00		
--------------	--	--

EPDM foam insert for frame cavities (15mm thick.)

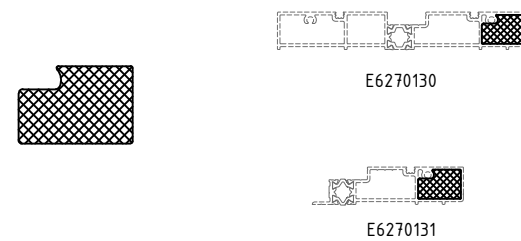

ET 076679.00		
--------------	--	--

EPDM side flange for double & triple flat rails

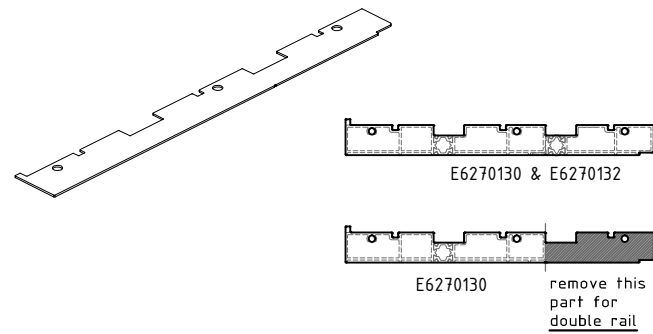

ET 076701.00		
--------------	--	--

EPDM side flange for double flat rail with fly screen

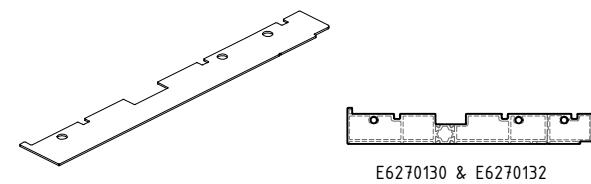

ES70.A-012

sliding system with thermal break

ES70

code/description	package/pcs	colour
ET 056607.00		inox
ET 057705.00		polyamid 6.6

Alignment square for ES70, E19, E22, E50, E52

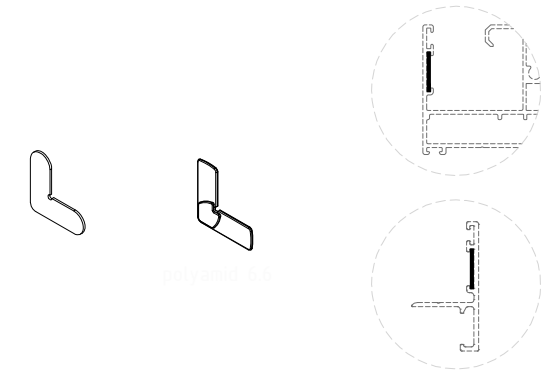

ET 055510.00		galv.steel
ET 055511.00		inox

Alignment square for sash E22214, E 19215



ET 053306.00		silver
--------------	--	--------

Die cast aluminium corner joint bracket for E19, E22

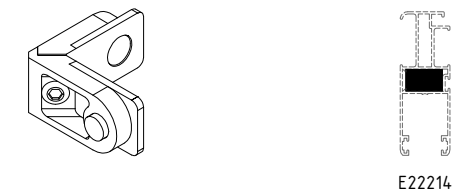

ET 053316.00		silver
--------------	--	--------

Die cast aluminium corner joint bracket

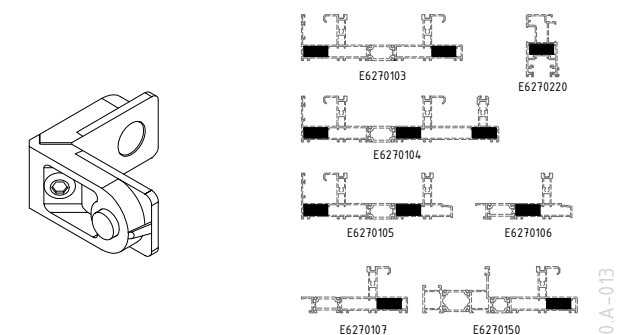

ES70.A-013

sliding system with thermal break

ES70

code/description	package/pcs	colour
ET 054255.00		MF
ET 054253.00		MF

Extruded aluminium joint corner bracket - 24.7mm without hole/with hole

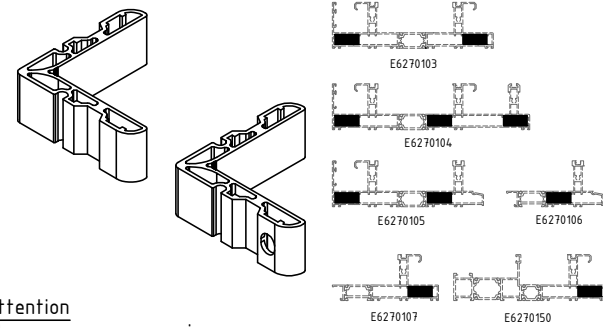

attention
always use epoxy resin
for long lasting joining

ET 052213.00		MF
--------------	--	----

Extruded aluminium corner joint for sash

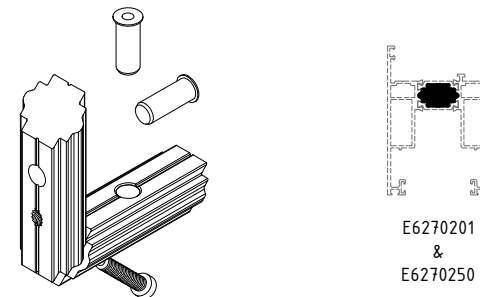

ET 057721.00		
--------------	--	--

Alignment corner for sash

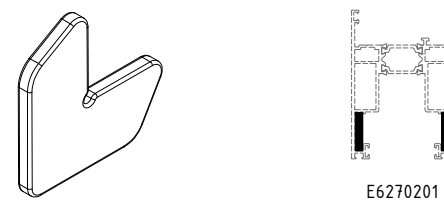

ET 054441.00		MF
--------------	--	----

Assembly corner for glazing sash

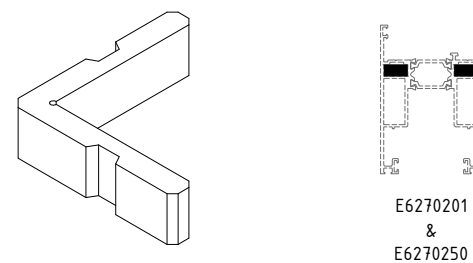

ES70.A-014

sliding system with thermal break

ES70

code/description	package/pcs	colour
ET 054447.00		MF

Extruded aluminium corner joint for sash

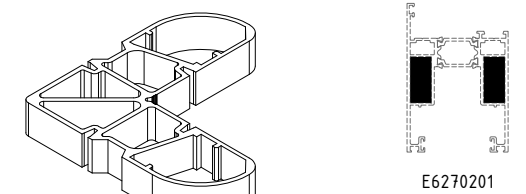

ET 054138.00		MF
--------------	--	----

Extruded aluminium corner joint for hotel type

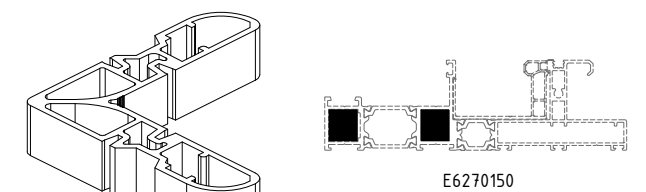

ET 058005.00		MF
--------------	--	----

Alignment corner for sash

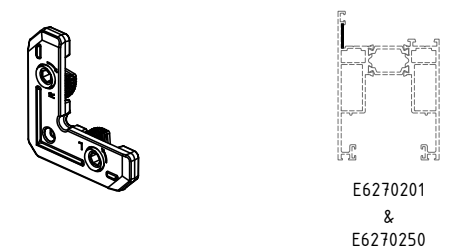

ET 056604.00		inox
--------------	--	------

Alignment square (5x1.25)



E6270220

ES70.A-015

sliding system with thermal break

ES70

code/description	package/pcs	colour
ET 240427.00		silver

Single roller for fly screen sash ("U" rail)

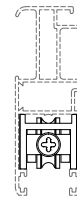
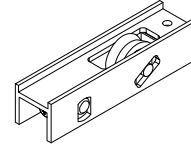

E22214

ET 240428.00		silver
--------------	--	--------

Single roller for fly screen sash (flat rail)

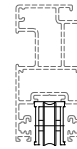
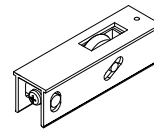

E6270220

ET 074786.00		●
--------------	--	---

Plastic bottom plug for interlock

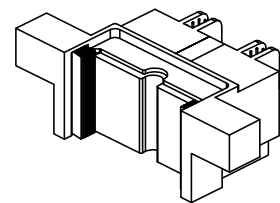

ET 074806.00		●
--------------	--	---

Plastic top plug for interlock

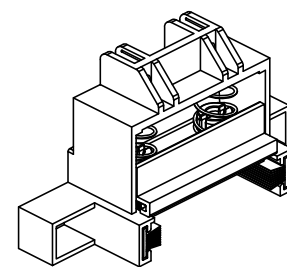

ES70 A-016

sliding system with thermal break

ES70

code/description	package/pcs	colour
ET 074811.00		●

Pair of plastic plugs for interlock

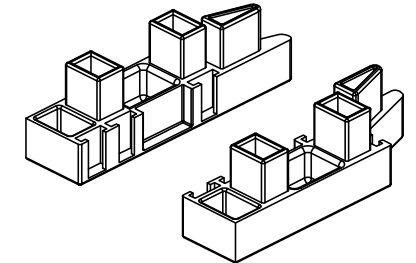

ET 074822.00		●
--------------	--	---

Plastic cap for PVC profile of slim interlock (pair)

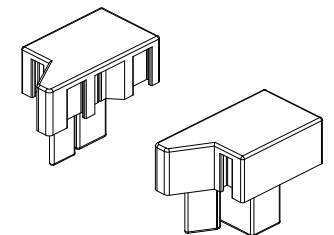

ET 074824.00		●
--------------	--	---

Central sealing plugs for opposed sashes (pair)

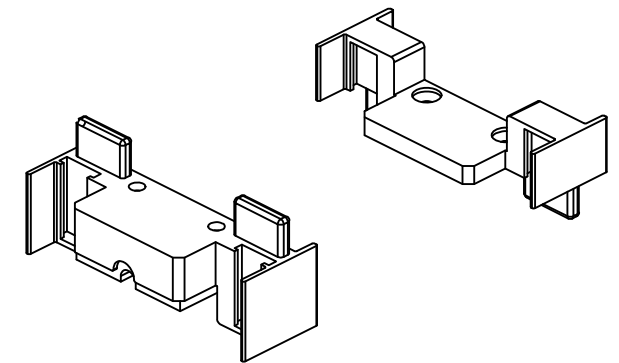

ET 074825.00		●
--------------	--	---

Central sealing plugs for opposed sashes with flat rail (pair)

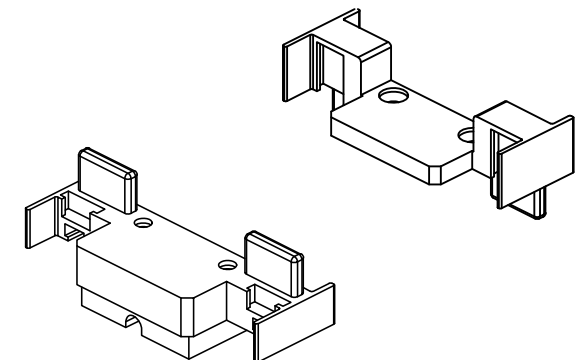

ES70 A-017

sliding system with thermal break

ES70

code/description	package/pcs	colour
ET 074471.00		●

Bottom interlock plug for flat rail

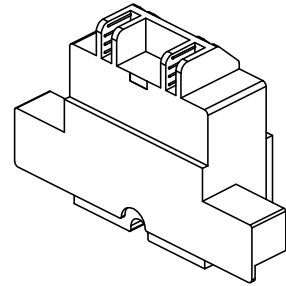

ET 074819.00		●
--------------	--	---

Roller spacers kit for flat rail

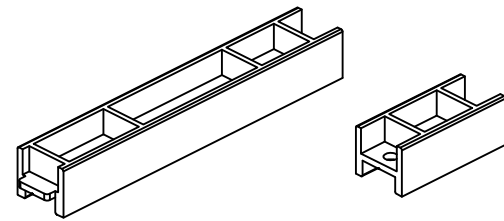

ET 240818.00		
--------------	--	--

Foam part for sealing sash - interlock on top for ES70 hotel type

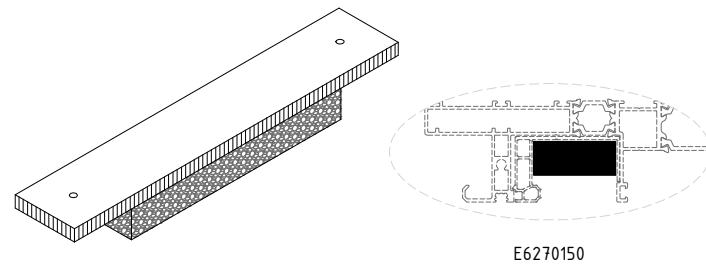

ET 240835.00		
--------------	--	--

Top foam part for sealing ES70 sash - interlock

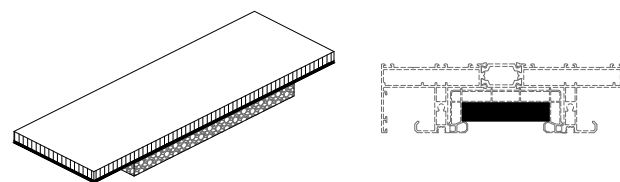

ES70-A-018

sliding system with thermal break

ES70

code/description	package/pcs	colour
ET 240836.00		

Top foam part for sealing ES70 sash - Slim interlock

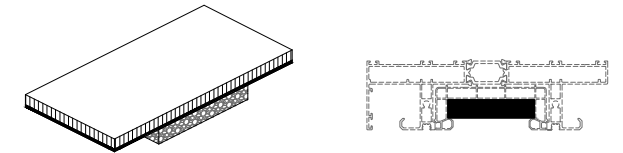

ET 240837.00		●
--------------	--	---

Central bottom sealing block for ES70 interlock

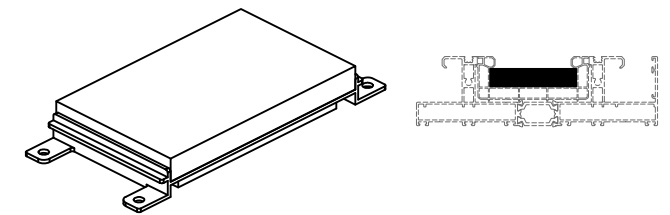

ET 240838.00		●
--------------	--	---

Central bottom sealing block for ES70 Slim interlock

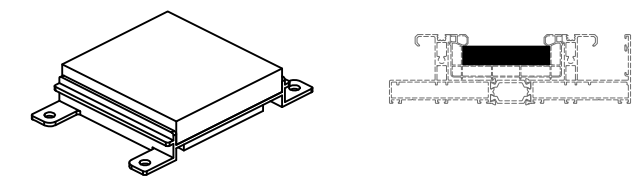

ET 240851.00		●
--------------	--	---

Central bottom sealing block for ES70 hotel type

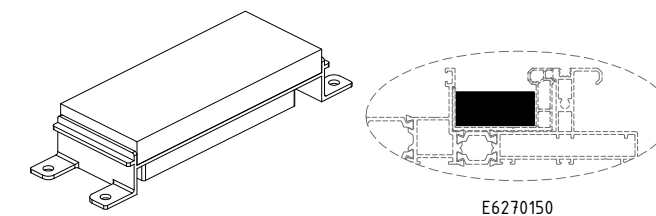

ES70-A-019

sliding system with thermal break

ES70

code/description	package/pcs	colour
ET 240857.00		●

Central bottom sealing block for ES70 hotel type (slim interlock)

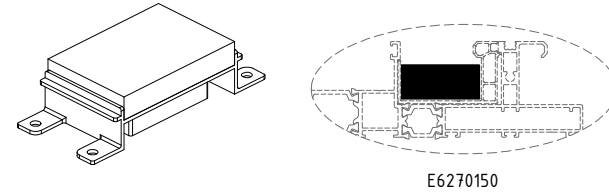

ET 240852.00		●
--------------	--	---

Bottom central sealing for flat rail

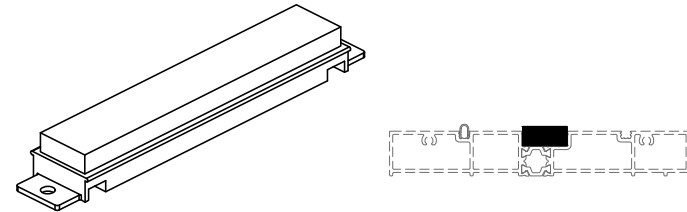

ET 240853.00		●
--------------	--	---

Bottom central sealing for flat rail (for slim interlock)

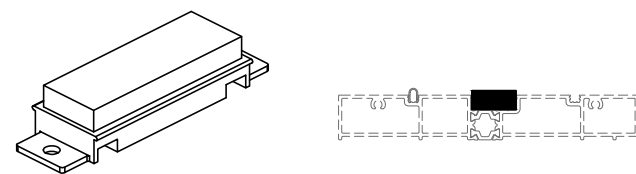

ET 074831.00		●
--------------	--	---

Stopper for flat rails fly screen

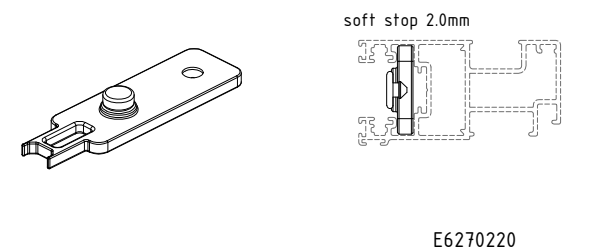

ES70-A-020

sliding system with thermal break

ES70

code/description	package/pcs	colour
ET 074308.00		●

Drainage cap for fly screen rail

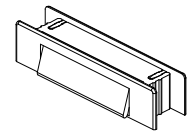

ET 074605.00		●
--------------	--	---

Plastic drainage cap 30x6mm

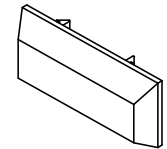

ET 074309.00		●
--------------	--	---

Open drainage plug for rails E6270103 & E6270104

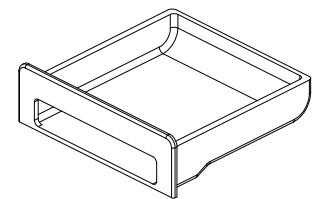

ET 074826.00		●
--------------	--	---

Open drainage plug for Hotel type rail

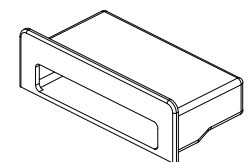

ES70-A-021

sliding system with thermal break

ES70

code/description	package/pcs	colour
ET 074830.00		●

Open drainage 35x10mm
for triple & multiple rails

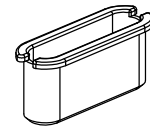

ET 074305.00		●
--------------	--	---

Drainage cap with flap

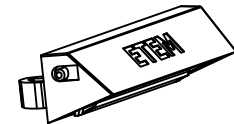

ET 074743.00		●
--------------	--	---

Plastic plug for fixing hole
covering

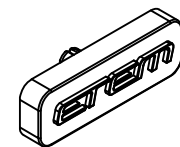

ET 074916.00		●
--------------	--	---

Pair of plastic plugs
for E22214

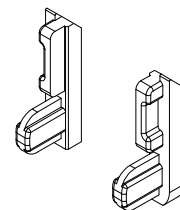

ES70-A-022

sliding system with thermal break

ES70

code/description	package/pcs	colour
ET 074827.00		

Glazing sash safety for
flat rail

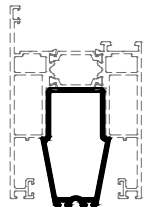
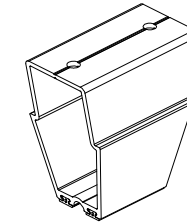

E6270201

ET 240423.00	1	
--------------	---	--

Spacer for fixed frame

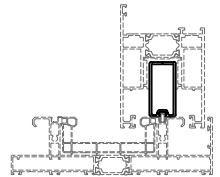
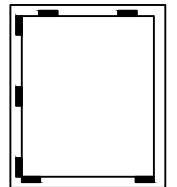
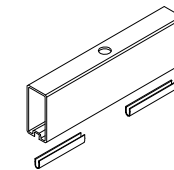

ET 071498.02		●
--------------	--	---

Aluminium reinforcement for
pvc interlock

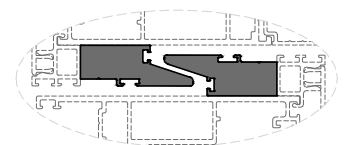
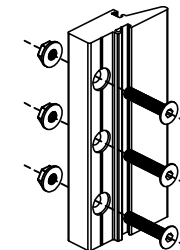

ET 074828.00		MF
--------------	--	----

Aluminium rail reinforcement

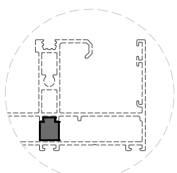
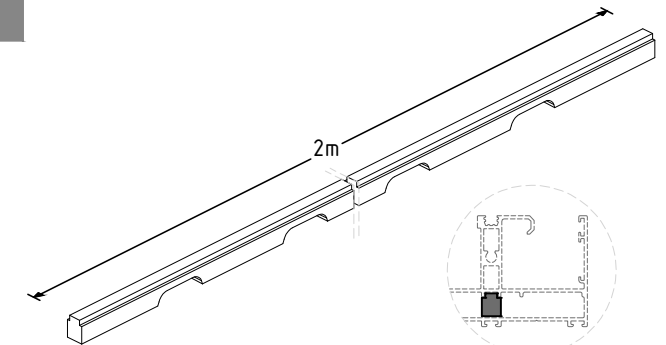

ES70-A-023

sliding system with thermal break

ES70

code/description	package/pcs	colour
GU 201055.00	1	MF

Connecting rod 8 mm
(for Sash W. 700 - 1600 mm)

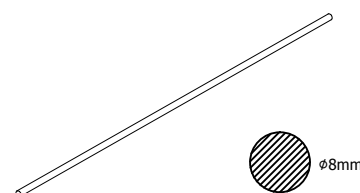

GU 201058.00	1	MF
--------------	---	----

Connecting rod 8 mm
(for Sash W. 1601 - 1850 mm)

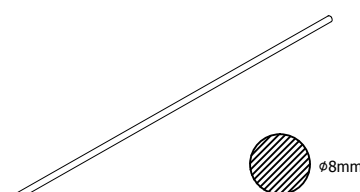

GU 201059.00	1	MF
--------------	---	----

Connecting rod 8 mm
(for Sash W. 1851 - 2350 mm)

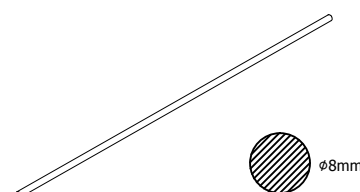

GU 201056.00	1	MF
--------------	---	----

Connecting rod 8 mm
(for Sash W. 2351 - 3300 mm)

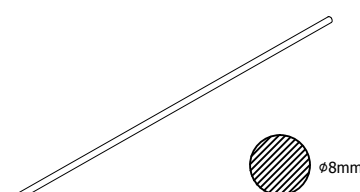

ES70-A-024

sliding system with thermal break

ES70

code/description	package/pcs	colour
GU 205108.00	1	MF

Screw M6x75 mm, DIN 965

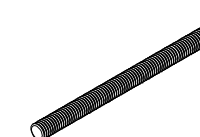

GU 205109.01	1	●
GU 205109.02	1	●
GU 205109.03	1	brown
GU 205109.11	1	silver

Flush pull 934



GU 205118.00	1	
--------------	---	--

Additional part for GU 934
18 mm

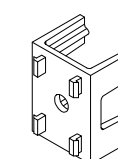

GU 250100.01	1	●
GU 250100.03	1	brown
GU 250100.11	1	silver

Flush pull 934 without
cylinder bore with screw
base plate



ES70-A-025

sliding system with thermal break

ES70

code/description	package/pcs	colour
GU 250102.01	1	●
GU 250102.02	1	●
GU 250102.03	1	brown
GU 250102.11	1	silver

Flush pull 934 without cylinder bore

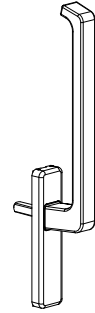

GU 250111.01	1	
--------------	---	--

Cover rail extension for gear GU 934, 500 mm

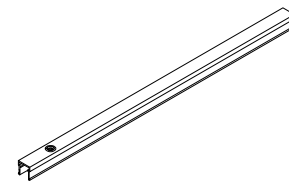

GU 250114.01	1	●
GU 250114.02	1	●
GU 250114.11	1	silver

Sash stopper for GU934/937

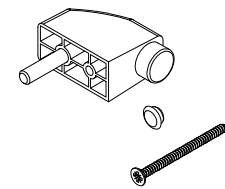

GU 250181.01	1	●
GU 250181.03	1	brown
GU 250181.11	1	silver

Removable handle 934

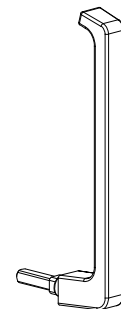

ES70-A-026

sliding system with thermal break

ES70

code/description	package/pcs	colour
GU 250125.01	1	●
GU 250125.03	1	brown
GU 250125.11	1	silver

Rosette for 934 handle without cylinder bore

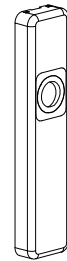

GU 250129.00	1	
--------------	---	--

Outer rosette for 934 handle

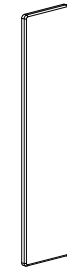

GU 250134.00	1	
--------------	---	--

Rollers GU 934

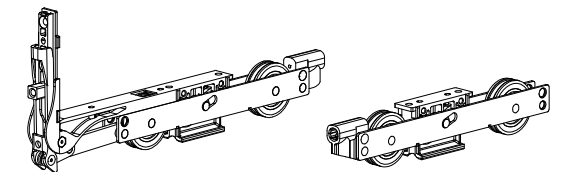

GU 250140.01	1	●
GU 250140.03	1	brown
GU 250140.11	1	silver

Both side handle 934, with cylinder hole

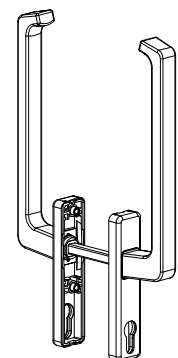

ES70-A-027

sliding system with thermal break

ES70

code/description	package/pcs	colour
GU 250119.00	1	

Ventilation striker for hardware 934

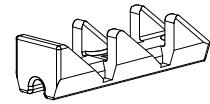

GU 250146.00	1	
--------------	---	--

Bottom spacer 18 mm for GU 934

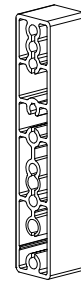

GU 250148.00	1	
--------------	---	--

Additional rollers basic kit for GU 934

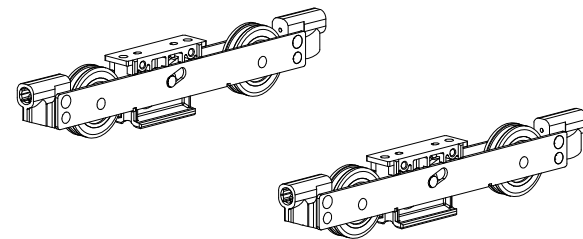

GU 250145.11	1	
--------------	---	--

Gear for GU 934 Silver for height 1865 - 2365 mm

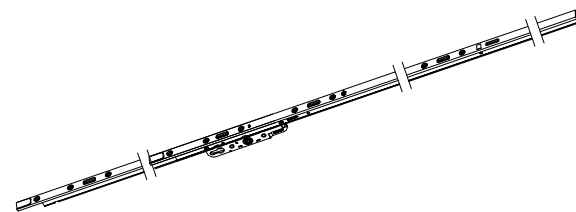

ES70-A-028

sliding system with thermal break

ES70

code/description	package/pcs	colour
GU 250149.11	1	

Gear for GU 934 Silver for height 865 - 1285 mm

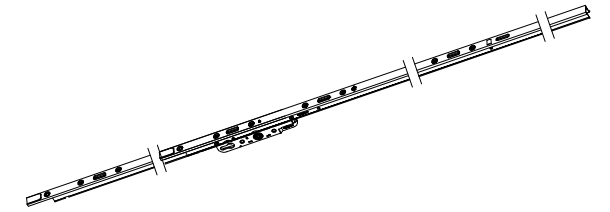

GU 250150.11	1	
--------------	---	--

Gear for GU 934 Silver for height 1235 - 1865 mm



GU 250151.11	1	
--------------	---	--

Gear for GU 934 Silver for height 2155 - 2765 mm



GU 250696.00	1	
--------------	---	--

Gear extension with locking point EV1

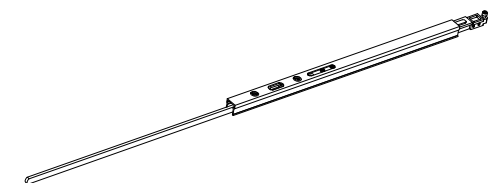

ES70-A-029

sliding system with thermal break

ES70

code/description	package/pcs	colour
GU 250147.00	1	

Frame striker for GU 934

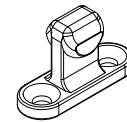

GU 250900.00	1	
--------------	---	--

Elastic interlock stopper for GU 934



ET 074773.00		
--------------	--	--

Water drainage valve
ø8.0 mm

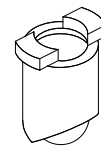

ET 074774.00		
--------------	--	--

Water drainage valve
ø12.0 mm



ES70.A-030

sliding system with thermal break

ES70

code/description	package/pcs	colour
ET 074840.00		

Pair of end caps for profile E6270520 - for 90° corner

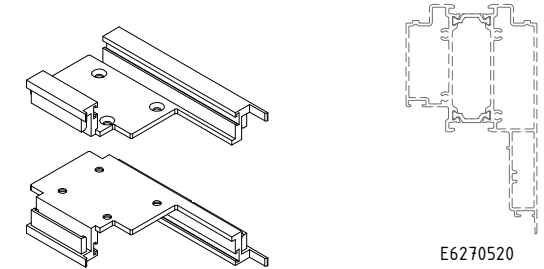

ET 057722.00		
--------------	--	--

Alignment corner for double or triple rail (for 90° corner)



ET 130729.00		
--------------	--	--

EPDM seal gasket for 90° corner

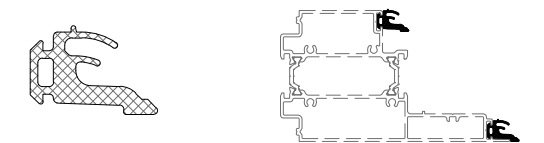

ET 055053.00		MF
--------------	--	----

Anchor for E6270520 with latch (for 90° corner)

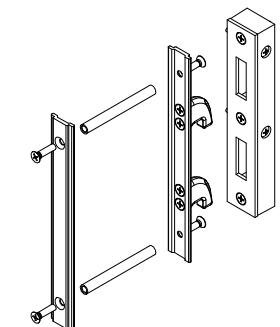

ES70.A-031

sliding system with thermal break

ES70

code/description	package/pcs	colour
ET 138001.00		transparent
ET 138001.01		white
ET 138001.02		black
ET 138001.03		brown
ET 138001.04		grey

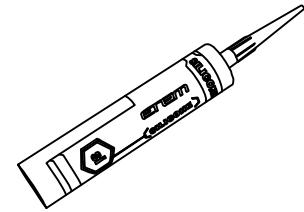

Silicone for general use 280ml

ET 138000.01		
--------------	--	--

Acrylic putty 280ml

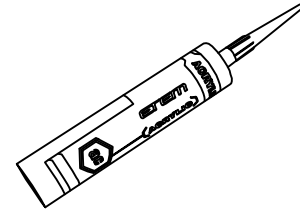

ET 138004.00		
--------------	--	--

One part adhesive (for crimping machine)
with a rapid vulcanisation 290ml

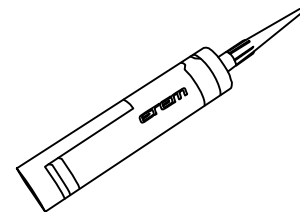

ET 133002.00		
--------------	--	--

Self-adhesive, self-expand tape
'SUPERSEAL 80' for watertightness
and sound insulation (4/20x20)

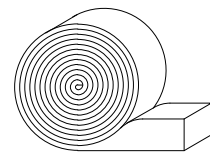

ES70-A-032

sliding system with thermal break

ES70

code/description	package/pcs	colour
ET 162269.00		

Punching machine for ES70

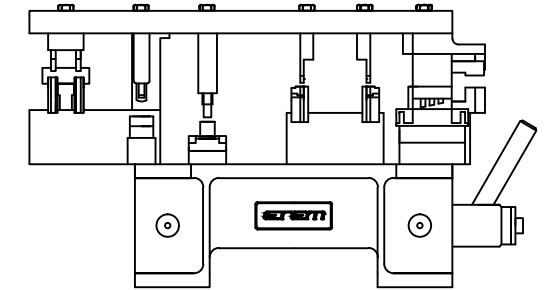

--	--	--

--	--	--

--	--	--

ES70-A-033

CE MARKING

STANDARDS / PERFORMANCE CHARACTERISTICS

CE MARKING

WHAT DOES THE SIGN CE MEAN?

It is an abbreviation of the French "Conformite Europeene"- i.e. European Conformity. By placing the CE marking the manufacturer declares that the product complies with the general safety requirements set out in the Construction Product Regulation 305/2011.

WHAT IS THE PURPOSE OF CE MARKING?

The CE marking represents "the European passport" of the product, its main objectives are:

CE is a declaration by the manufacturer that the product meets the essential requirements of relevant European legislation relating to health, safety and environmental protection;

CE indicates to officials in relevant ministries and departments that the product can be put on the market lawfully in the country;

CE ensures free movement of goods within the EU and the European Free Trade Association (EFTA);

CE permits the withdrawal of products that do not meet the standards by monitoring and custom authorities; marking with the CE mark is necessary in cases where the product is distributed within the internal market.

WHAT ARE THE REQUIREMENTS FOR THE CE MARKING?

Doors, windows and gates (except those intended to be used for internal communication only, for fire/smoke compartmentation and on escape routes) are covered by System 3 of assessment and verification of constancy of performance.

According to the Construction Product Regulation 305/2011, this system sets the following duties:

Tasks to be performed by the manufacturer	Tasks to be performed by Notified testing laboratory	Conformity assessment (the basis for CE marking, which is set by the final producer)
factory production control - FPC	Determination of the product type on the basis of type testing, type calculation, tabulated values, etc.	Declaration of performance issued by the manufacturer or his authorized representative based on test results.

LEGAL ACTS

- Construction Products Regulation (305/2011/EU - CPR) – replacing the Construction Products Directive (89/106/EEC - CPD)
- EN 14351-1:2006+A1:2010 - Windows and doors - Product standard, performance characteristics - Part 1: Windows and external pedestrian doorsets without resistance to fire and/or smoke leakage characteristics

MAIN METHODS FOR OBTAINING TEST RESULTS BY THE MANUFACTURER

According to the Construction Product Regulation 305/2011 there are three main options for the manufacturers of windows and doors to obtain test results.

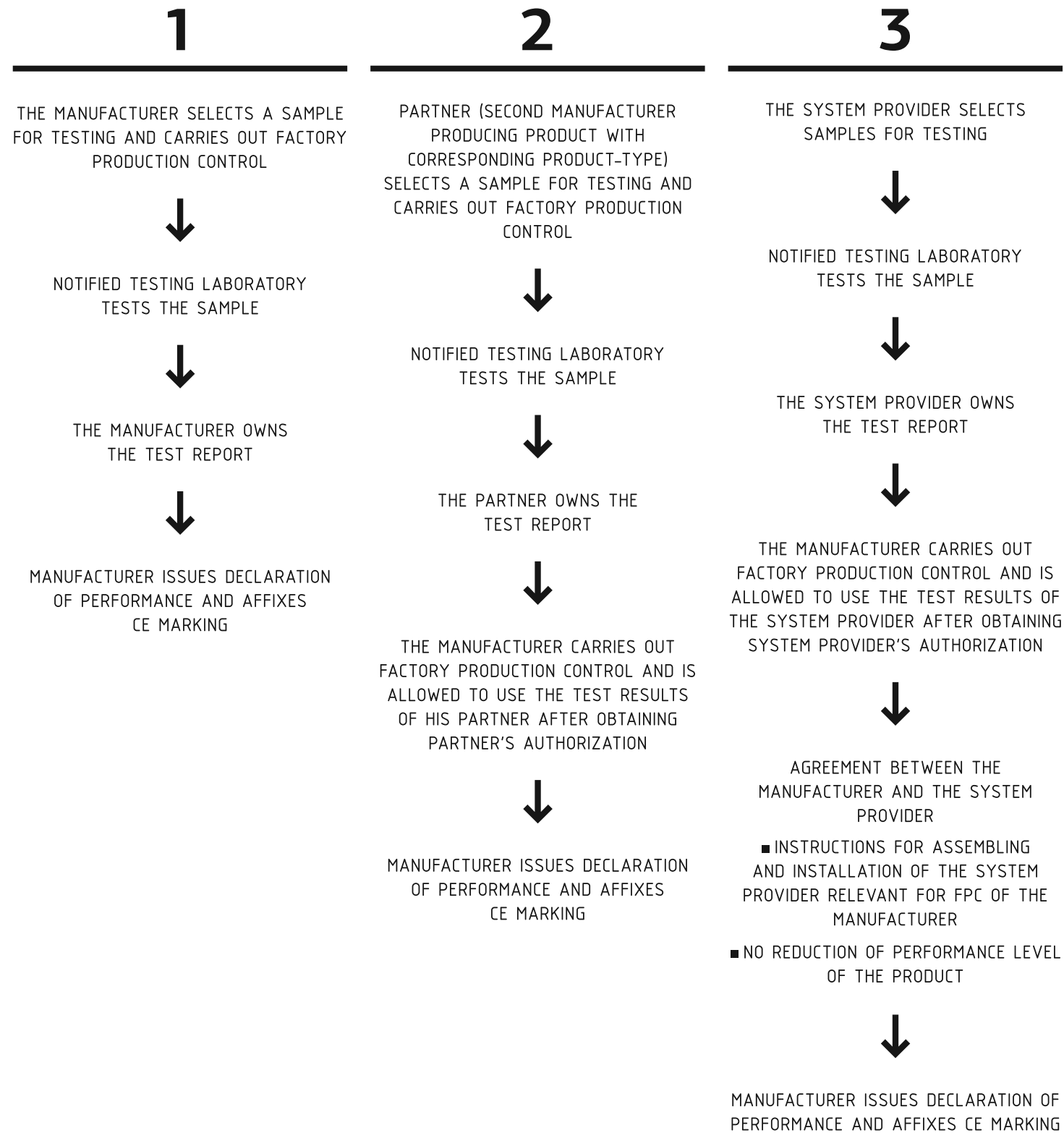

STANDARDS

GENERAL

- EN 12020 (1÷2) - ALUMINIUM AND ALUMINIUM ALLOYS - EXTRUDED PRECISION PROFILES IN ALLOYS EN AW-6060 AND EN AW-6063
- EN 755 (1÷9)- ALUMINIUM AND ALUMINIUM ALLOYS - EXTRUDED ROD/BAR, TUBE AND PROFILES
- EN 573 (1÷3) - ALUMINIUM AND ALUMINIUM ALLOYS - CHEMICAL COMPOSITION AND FORM OF WROUGHT PRODUCTS
- EN 1990 EUROCODE - BASIS OF STRUCTURAL DESIGN
- EN 1991 EUROCODE 1 - ACTIONS ON STRUCTURES
- EN 1998 EUROCODE 8 - DESIGN OF STRUCTURES FOR EARTHQUAKE RESISTANCE
- EN 1999 EUROCODE 9 - DESIGN OF ALUMINIUM STRUCTURES

WINDOWS AND DOORS

1. EN 14351 - WINDOWS AND DOORS - PRODUCT STANDARD, PERFORMANCE CHARACTERISTICS
2. EN 12519 - WINDOWS AND PEDESTRIAN DOORS - TERMINOLOGY
3. EN 12207 - WINDOWS AND DOORS - AIR PERMEABILITY - CLASSIFICATION
4. EN 1026 - WINDOWS AND DOORS - AIR PERMEABILITY - TEST METHOD
5. EN 12208 - WINDOWS AND DOORS - WATERTIGHTNESS - CLASSIFICATION
6. EN 1027 - WINDOWS AND DOORS - WATERTIGHTNESS - TEST METHOD
7. EN 12210 - WINDOWS AND DOORS - RESISTANCE TO WIND LOAD - CLASSIFICATION
8. EN 12211 - WINDOWS AND DOORS - RESISTANCE TO WIND LOAD - TEST METHOD
9. EN 1191 - WINDOWS AND DOORS - RESISTANCE TO REPEATED OPENING AND CLOSING - TEST METHOD
10. EN ISO 10077 (1÷2) - THERMAL PERFORMANCE OF WINDOWS, DOORS AND SHUTTERS - CALCULATION OF THERMAL TRANSMITTANCE
11. EN 12412-2 - THERMAL PERFORMANCE OF WINDOWS, DOORS AND SHUTTERS - DETERMINATION OF THERMAL TRANSMITTANCE BY HOT BOX METHOD - PART 2: FRAMES
12. EN 13115 - WINDOWS - CLASSIFICATION OF MECHANICAL PROPERTIES - RACKING, TORSION AND OPERATING FORCES
13. EN 1627 - WINDOWS, DOORS, SHUTTERS - BURGLAR RESISTANCE - REQUIREMENTS AND CLASSIFICATION
14. EN 1628 - WINDOWS, DOORS, SHUTTERS - BURGLAR RESISTANCE - TEST METHOD FOR THE DETERMINATION OF RESISTANCE UNDER STATIC LOADING
15. EN 1629 - WINDOWS, DOORS, SHUTTERS - BURGLAR RESISTANCE - TEST METHOD FOR THE DETERMINATION OF RESISTANCE UNDER DYNAMIC LOADING
16. EN 1630 - WINDOWS, DOORS, SHUTTERS - BURGLAR RESISTANCE - TEST METHOD FOR THE DETERMINATION OF RESISTANCE TO MANUAL BURGLARY ATTEMPTS
17. EN ISO 717-1 - ACOUSTICS - RATING OF SOUND INSULATION IN BUILDINGS AND OF BUILDING ELEMENTS - PART 1: AIRBORNE SOUND INSULATION
18. EN ISO 10140 - ACOUSTICS - LABORATORY MEASUREMENT OF SOUND INSULATION OF BUILDING ELEMENTS

HATCHES

Hatches for different materials

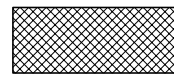

EPDM

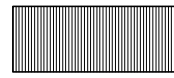

PVC

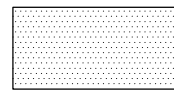

gypsum board



silicone seal

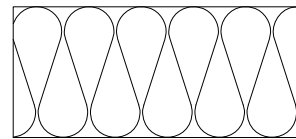

Insulation soft

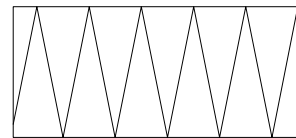

Insulation hard

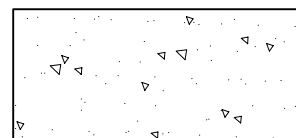

concrete wall

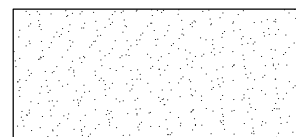

plaster

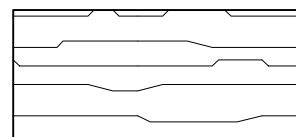

wood



butyl seal



membrane

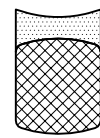

silicone seal



backer rod



PVC spacer



etalbond

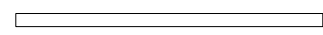

sheet aluminium

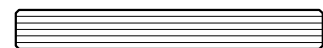

glass



aluminium profile

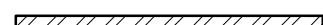

steel

LIABILITY

The stated data and calculating methods are provided by ETEM as a guideline only. The information given in this catalogue does not substitute of all applicable regulations – Eurocodes, harmonized European standards, national or regional building codes.

The specific conditions and technical details of every particular project have to be taken into consideration.

The right choice of all elements as well as any special requirements regarding stability of the structure must always be considered by the structural/façade engineer, responsible for the project.

The solutions presented in these pages are indicative and can not cover all possible project cases. Because of that every single project has to be evaluated by the structural/facade engineer in charge taking into consideration the specific features, such as climate conditions, location, orientation, etc.

ETEM is not liable for any calculations and conclusions made on the basis of the stated information. All calculations and specifications must be estimated, endorsed and guaranteed by architect, engineer, professional or legal entity authorized by law for such activities.

COPYRIGHT

Copyright© II EDITION 2021 ETEM

The design, structure and content of this catalogue are subject of copyright and the exclusive rights belong to ETEM. Modifying, copying, publishing, selling or licensing any part or the whole content of this catalogue are strongly prohibited without the permission of ETEM.

Any unauthorized use of content may violate copyright or other laws.

DISCLAIMER

ETEM is not responsible for any typographical errors, technical inaccuracies and following changes of the content of this catalogue.

Before starting manufacturing process, it is highly recommended to contact ETEM R&D department in order to provide you with updated information.





WWW.ETEM.COM

ETEM