

Q60 E85

# TECHNICAL CATALOGUE

FLAT DOOR SYSTEMS WITH THERMAL BREAK

E70

E52

E75FD

E68

E75FPD

EB62

EP30

Q72

E45

EF50



# E75FD

# E75FPD

FLAT DOOR SYSTEMS WITH THERMAL BREAK

## TABLE OF CONTENTS

BUILDING PHYSICS page 9

### I.

#### E75FD FLAT DOOR SYSTEM WITH THERMAL BREAK

GENERAL INFORMATION	page 23
TABLES	page 27
PROFILES	page 33
SECTIONS	page 43
GLAZING OPTIONS	page 67
CUTTING LISTS & MACHINING	page 71
ACCESSORIES	page 137

### II.

#### E75FPD FLAT DOOR SYSTEM WITH THERMAL BREAK

GENERAL INFORMATION	page 161
TABLES	page 165
PROFILES	page 171
SECTIONS	page 179
CUTTING LISTS & MACHINING	page 197
ACCESSORIES	page 225

### III.

CE MARKING	page 241
------------	----------

# ETEM HISTORY

ETEM is a leading aluminium extrusion company. It was founded in 1971 as a part of the largest metal manufacturing holding on the Balkans. With over 50 years of experience ETEM is a fully integrated designer and producer of architectural systems and aluminium profiles for industrial applications.

Our mission is to listen and promptly respond to our customers' requests and design and manufacture aluminium products and systems, taking into consideration technical and aesthetic requirements.

ETEM focuses on sustainable development and has proven its concern about the protection of the natural environment by making considerable investments in anti-pollution measures and by optimizing production processes following the applicable standards of the European Union.

## SERVICES WE PROVIDE

ETEM supports you with the following:

- ▷ design of conventional and bespoke architectural system solutions
- ▷ innovative engineering in the field of curtain walls, ventilated facades, doors, windows
- ▷ professional consultation and adequate technical advices ensured by our engineering team with wide experience in the field of profile extrusion as well as architectural systems' engineering

- ▷ reliable customer care constant support trainings, technical support and audits on site
- ▷ high quality engineering which guarantees offering the best solution according to the specific features of every single project
- ▷ managing the process of certification in accordance with the applicable European standards in Notified Bodies
- ▷ production of non-standard length profiles and non-standard processing
- ▷ high quality powder coating

# ETEM PRODUCTS AND SUSTAINABLE DEVELOPMENT

SUSTAINABLE DEVELOPMENT IS DEVELOPMENT THAT MEETS THE NEEDS OF THE PRESENT WITHOUT COMPROMISING THE ABILITY OF FUTURE GENERATIONS TO MEET THEIR OWN NEEDS.\*

For many, sustainable development is about environmental conservation. This is true but it also includes two other aspects: a social aspect and an economic aspect.

Sustainable development means striking the right balance between economic development, social equity and environmental protection.

For us meeting this objective translates into the challenge of satisfying market demands at the lowest economic, social and environmental cost possible.

ETEM has always designed architectural systems which are in compliance with all requirements for achieving high energy efficiency.

In order to assure the comfort of the building inhabitants, ETEM systems adapt their functions to the changing environment.

As a moderator between outside and inside our systems provide:

- ▷ ENERGY EFFICIENCY
- ▷ DAYLIGHT
- ▷ SUN-SHADING
- ▷ VENTILATION AND GOOD AIR QUALITY
- ▷ SAFETY AND SECURITY

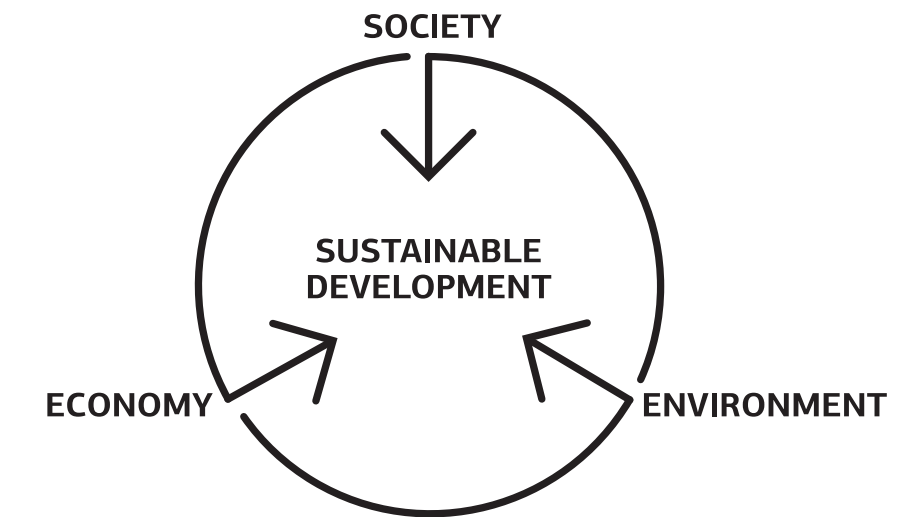

# BUILDING PHYSICS

DIMENSIONING / FORMULAS / EXAMPLES

# ALUMINIUM AS MATERIAL

ALUMINIUM IS A VERY YOUNG METAL, EXTRACTED FOR THE FIRST TIME IN 1854. COMMERCIALY PRODUCED AS A PRECIOUS METAL FROM 1886, ITS INDUSTRIAL PRODUCTION FOR CIVIL APPLICATIONS ONLY ACHIEVED WIDE USE IN THE 1950'S.

NOW ALUMINIUM PLAYS A KEY ROLE FOR THE SUSTAINABILITY OF NEW BUILDINGS AND THE RENOVATION OF EXISTING ONES. THANKS TO ITS PERFORMANCE PROPERTIES ALUMINIUM CONTRIBUTES TO THE ENERGY PERFORMANCE, SAFETY AND COMFORT OF NEW BUILDINGS.

## ADVANTAGES

### DESIGN FLEXIBILITY

The extrusion process offers an almost infinite range of forms and sections, allowing designers to integrate numerous functions into one profile

### LONG SERVICE LIFE

Aluminium building products are made from alloys that are weatherproof, corrosion-resistant and immune to the harmful effects of UV rays, ensuring optimal performance over a very long period of time

### HIGH STRENGTH-TO-WEIGHT RATIO

Thanks to the metal's inherent strength and stiffness, aluminium window and curtain wall frames can be very narrow. Material's light weight makes it easier to transport and handle on-site, reducing the risk of work-related injury

### HIGH-REFLECTIVITY

This characteristic feature makes aluminium a very efficient material for light management. Aluminium shading devices can be used to reduce the need for air conditioning in summer

### FIRE SAFETY

Aluminium does not burn and therefore is classified as a non-combustible construction material (European Fire Class A1). Aluminium alloys will nevertheless melt at around 650°C but without releasing harmful gases

### NO RELEASE OF DANGEROUS SUBSTANCES

Several studies have proved that aluminium building products do not present a hazard to occupants or the surrounding environment. Aluminium building products have no negative impact, either on indoor air quality or on soil, surface and groundwater

### OPTIMAL SECURITY

Where high security is required, specially designed, strengthened aluminium frames can be used. While the glass for such applications may well be heavy, the overall weight of the structure remains manageable thanks to the light weight of the aluminium frames.

## ALLOYS

Aluminium in its pure form is a very soft metal. Thanks to the addition of alloying elements such as copper, manganese, magnesium, zinc, etc. and thanks to suitable production processes, the physical and mechanical properties can be varied in a wide range to satisfy the requirements of a large number of different applications.

ETEM profiles are extruded from the following alloys:

**EN AW-1050 [Al 99.5]**

**EN AW-6060 [Al Mg Si]**

**EN AW-6063 [Al Mg0,7 Si]**

**EN AW-6061 [Al Mg1 Si Cu]**

**EN AW-6005 [Al Si Mg]**

**EN AW-6082 [Al Si1 Mg Mn]**

The most common aluminium alloy which is used by ETEM is EN AW 6063.

Here are the properties of this alloy:

### MATERIAL PROPERTIES

<b>Aluminium alloy</b>	EN AW 6063 F22
<b>Ultimate tensile strength</b>	Rm = 210 N/mm <sup>2</sup>
<b>Yield strength</b>	R <sub>0,2</sub> = 160 N/mm <sup>2</sup>
<b>Modulus of elasticity</b>	Eal=70 000 N/mm <sup>2</sup> = 7.10 <sup>9</sup> kg/m <sup>2</sup>
<b>Coefficient of thermal expansion</b>	α=0,023 mm/m .K (up to 1,2 mm/m for difference up to 50°C)

## EXTRUSION PROCESS

ETEM profiles are obtained through extrusion process, which consists of pushing a hot cylindrical bullet of aluminium through a shaped die. The extrusion process offers almost infinite range of forms and sections, allowing our designers to integrate numerous functions into one single profile.

aluminium surface, increasing hardness, corrosion and abrasion resistance. Anodizing gives a very decorative silver matt surface finish, and colored can also be obtained by sealing metallic dyes into the anodized layer.

## MAINTENANCE

Apart from routine cleaning for aesthetic reasons, ETEM aluminium profiles do not require any maintenance which translates into a major cost and ecological advantage over lifetime of the product.

## RECYCLING

Aluminium scrap can be repeatedly recycled without any loss of value or properties. In many instances, aluminium is combined with other materials such as steel or plastics, which are most frequently mechanically separated from aluminium before being molten.

## FINISHING

### POWDER COATING

It is a type of paint that is applied as a dry powder. Coating is applied on ETEM profiles electrostatically and then is cured under heat to allow it to flow and form a "skin".

ETEM is authorized to use the quality sign QUALICOAT for powder coatings on aluminium for architectural applications. A wide range of colors and gloss levels can be achieved.

ETEM also offers timber imitations painting, in addition to all RAL colors. The technology EZY provides the following colors: Golden Oak, Acero, Betulla, Mogano, Verde Scuro, Wenge, Noce Fiammato, Noce Chiaro, Ciliegio Rosso, Acacia Scuro, Ciliegio Antico, Noce Reale, Ciliegio Reale.

### ANODIZING

It is an electrochemical process whereby to reinforce the natural oxide film on the

## WIND LOAD

Wind action

The main influence over the facade is wind action, which depends mainly on the height of the curtain wall and location.

As a guideline, the wind pressure values with respect to the structure height are given in the table below:

Building Height	Wind Velocity	Wind Load		Wind Pressure		Wind Suction in a middle zone				Wind Suction in an edge zone		
		q = $\frac{V^2}{16}$		Wp* = 1,25 x cp x q	cp = 0,8	h/b ≤ 0,25 Ws = cp x q cp = 0,5	h/b ≥ 0,5 Ws = cp x q cp = 0,7	b/8 ≤ 2 m Ws = cp x q cp = 2,0				
m	m/s	kg/m2	kg/m2	kg/m2	kg/m2	kg/m2	kg/m2	kg/m2	kg/m2	kg/m2	kg/m2	kg/m2
0 - 8	28,3	50	0,5	50	0,5	25	0,25	35	0,35	100	1,0	
8 - 20	35,8	80	0,8	80	0,8	40	0,40	56	0,56	160	1,6	
20 - 100	42,0	110	1,1	110	1,1	55	0,55	77	0,77	220	2,2	
> 100	45,6	130	1,3	130	1,3	65	0,65	91	0,91	260	2,6	

where:

h - building height, m

b - building width, m

v - wind velocity, m/s

q - wind load, kg/m2 and kN/m<sup>2</sup>

w<sub>p/s</sub> - wind pressure / suction ,kN/m<sup>2</sup>

cp - correction factor

\*Note: When calculating wind pressure w<sub>p</sub> the load is increased with 25%

## UNITS CONVERTER

1m = 100cm = 1000mm

1kg = 10N  
1kN = 100kg = 1000N

1kg/m<sup>2</sup> = 0,01kN/m<sup>2</sup>  
1Pa = 1N/m<sup>2</sup> = 0,1kg/m<sup>2</sup>  
1kPa = 1000Pa = 1kN/m<sup>2</sup> =100kg/m<sup>2</sup>  
1MPa = 1000kPa = 1 000 000 Pa  
1MPa = 1N/mm<sup>2</sup> = 0,1kN/cm<sup>2</sup> =100 000kg/m<sup>2</sup>

## MULLION SELECTION

### \*Wind load actions:

The required moment of inertia of a mullion due to the wind action is given by:

a) triangle load

$$\text{If } \frac{H}{c} \leq 1, I_{yc} \geq \frac{w \cdot (H/2) \cdot H^4 \cdot 10^8}{120 \cdot E_{al} \cdot f_{max}}, \text{cm}^4$$

or

b) trapezoid load

$$\text{If } \frac{H}{c} > 1, I_{yc} \geq \frac{w \cdot (C/2) \cdot H^4}{1920 \cdot E_{al} \cdot f_{max}} \cdot 10^8 \cdot \left[ 25 - 40 \cdot \frac{(C/2)^2}{H^2} + 16 \cdot \frac{(C/2)^4}{H^4} \right], \text{cm}^4$$

Use the same method to calculate  $I_{yd}$

Total of required moment of inertia:

$$I_y = I_{yc} + I_{yd}, \text{cm}^4$$

Where:

$I_y$  - Moment of inertia of a transom,  $\text{cm}^4$   
 $w$  - Wind pressure,  $\text{kg/m}^2$   
 $E_{al}$  - Modulus of Elasticity of aluminium,  $\text{kg/m}^2$   
 $f_{max}$  - Maximum transom deflection, m  
 $H$  - Length of a mullion, m  
 $a, b$  - Distance between mullions, m

Maximum transom deflection  $f_{max}$  by wind load:

$$f = \frac{H}{200}, \text{m} \text{ or } 0,015 \text{ m - whichever is less (EN 14351-1)}$$

Use ETEM Catalogue to choose the appropriate mullion with  $I_y$  exceeding or equal to the required  $I_y$ .

Use ETEM Catalogue to choose the appropriate profile which characteristics exceed or are equal to both calculated values  $I_x$  and  $I_y$ .

Example:

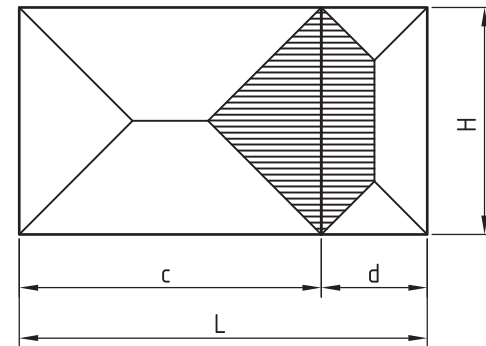

Initial data:

$H = 2,2 \text{ m}$        $w = 60 \text{ kg/m}^2$   
 $c = 2,4 \text{ m}$        $E_{al} = 7 \cdot 10^9 \text{ kg/m}^2$   
 $d = 0,8 \text{ m}$

$$f = \frac{H}{200} = \frac{2,2}{200} = 0,011 \text{m} \text{ or } 0,015 \text{ m (EN 14351-1)}$$

$\Rightarrow f_{max} = 0,011 \text{m}$  in the following formulas:

$$\frac{H}{c} = \frac{2,2}{2,4} = 0,91 < 1$$

$$I_{yc} \geq \frac{w \cdot (H/2) \cdot H^4 \cdot 10^8}{120 \cdot E_{al} \cdot f_{max}}, \text{cm}^4$$

$$I_{yc} \geq \frac{60 \cdot (2,2/2) \cdot 2,2^4 \cdot 10^8}{120 \cdot 7 \cdot 10^9 \cdot 0,011}, \text{cm}^4 \Rightarrow I_{yc} \geq 16,73 \text{ cm}^4$$

$$\frac{H}{d} = \frac{2,2}{0,8} = 2,75 > 1$$

$$I_{yd} \geq \frac{w \cdot (d/2) \cdot H^4}{1920 \cdot E_{al} \cdot f_{max}} \cdot 10^8 \cdot \left[ 25 - 40 \cdot \frac{(d/2)^2}{H^2} + 16 \cdot \frac{(d/2)^4}{H^4} \right], \text{cm}^4$$

$$I_{yd} \geq \frac{60 \cdot (0,8/2) \cdot 2,2^4}{1920 \cdot 7 \cdot 10^9 \cdot 0,011} \cdot 10^8 \cdot \left[ 25 - 40 \cdot \frac{(0,8/2)^2}{2,2^2} + 16 \cdot \frac{(0,8/2)^4}{2,2^4} \right], \text{cm}^4$$

$$I_{yd} \geq 9,01 \text{ cm}^4$$

$$I_y = I_{yc} + I_{yd}, \text{cm}^4 \Rightarrow I_y = 16,73 + 9,01 = 25,74 \text{ cm}^4$$

Use ETEM Catalogue to choose the appropriate mullion with

$$I_y \geq 25,74 \text{ cm}^4$$

We choose mullion E75300S with  $I_x = 13,91 \text{ cm}^4$   
 and  $I_y = 41,75 \text{ cm}^4$

## TRANSOM SELECTION

### \*Dead load actions:

\*Glass pane self weight:

Weight of the glass pane  $G$  is calculated as follows:

The required moment of inertia of a transom due to the weight of the glazing is given by:

$$I_{x1} \geq \frac{G \cdot a \cdot 10^8}{48 \cdot E_{al} \cdot f_{max}} \cdot (3 \cdot L^2 - 4 \cdot a^2), \text{cm}^4$$

Where:

$G$  - Weight of glass pane, kg  
 $t$  - Glass pane thickness, mm  
 $\rho_{glass}$  - Density of glass material,  $\text{kg/m}^2/\text{mm}$   
 $l_g$  - Horizontal dimension of the glass pane, m  
 $h_g$  - Vertical dimension of the glass pane, m

\*Transom self weight:

The required moment of inertia of a transom due to its self weight is given by:

$$I_{x2} \geq \frac{5 \cdot q \cdot L^4 \cdot 10^8}{384 \cdot E_{al} \cdot f_{max}}, \text{cm}^4$$

Total of required moment of inertia:

$$I_x = I_{x1} + I_{x2}, \text{cm}^4$$

Where:

$a=0,15$  - Distance of a glazing supports of the glass pane, m  
 $I_x$  - Moment of inertia of a transom,  $\text{cm}^4$   
 $q$  - Self weight of a transom per linear meter,  $\text{kg/m}$   
 $E_{al}$  - Modulus of Elasticity of aluminium,  $\text{kg/m}^2$   
 $f_{max}$  - Maximum transom deflection, m  
 $L$  - Length of a transom, m

Maximum transom deflection  $f_{max}$  by dead load:

$$f = \frac{L}{500}, \text{m} \text{ or } 0,003 \text{ m - whichever is less (EN 14351-1)}$$

Use ETEM Catalogue to choose the appropriate transom with  $I_y$  exceeding or equal to the required  $I_y$ .

Use ETEM Catalogue to choose the appropriate profile which characteristics exceed or are equal to both calculated values  $I_x$  and  $I_y$ .

Example:  $G = t \cdot \rho_{glass} \cdot l_g \cdot h_g$

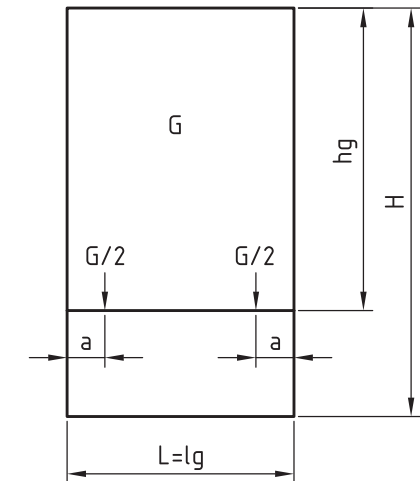

Initial data:

$t = 12 \text{ mm}$        $E_{al} = 7 \cdot 10^9 \text{ kg/m}^2$   
 $l_g = 1,5 \text{ m}$        $\rho_{glass} = 2,5 \text{ kg/m}^2/\text{mm}$   
 $h_g = 2,0 \text{ m}$        $q = 2 \text{ kg/m}$   
 $a = 0,15 \text{ m}$

$$G = t \cdot \rho_{glass} \cdot l_g \cdot h_g = 10 \cdot 2,5 \cdot 1,5 \cdot 2,0 = 75 \text{ kg}$$

$$\Rightarrow f_{max} = \frac{L}{500} = \frac{1,5}{500} = 0,003 \text{m} \text{ or } 0,003 \text{m (EN 14351-1)}$$

$\Rightarrow f_{max} = 0,003 \text{m}$  in the following formulas:

$$I_{x1} \geq \frac{G \cdot a \cdot 10^8}{48 \cdot E_{al} \cdot f_{max}} \cdot (3 \cdot L^2 - 4 \cdot a^2), \text{cm}^4$$

$$I_{x1} \geq \frac{75 \cdot 0,15 \cdot 10^8}{48 \cdot 7 \cdot 10^9 \cdot 0,003} \cdot (3 \cdot 1,5^2 - 4 \cdot 0,15^2), \text{cm}^4$$

$$I_{x1} \geq \frac{75 \cdot 0,15 \cdot 10^8}{48 \cdot 7 \cdot 10^9 \cdot 0,003} \cdot (3 \cdot 1,5^2 - 4 \cdot 0,15^2), \text{cm}^4 \Rightarrow I_{x1} \geq 7,43 \text{cm}^4$$

$$I_{x2} \geq \frac{5 \cdot q \cdot L^4 \cdot 10^8}{384 \cdot E_{al} \cdot f_{max}}, \text{cm}^4 \quad J_{x2} \geq \frac{5 \cdot 2 \cdot 1,5^4 \cdot 10^8}{384 \cdot 7 \cdot 10^9 \cdot 0,003}, \text{cm}^4 \Rightarrow I_{x2} \geq 0,63 \text{cm}^4$$

$$I_x = I_{x1} + I_{x2}, \text{cm}^4$$

$$I_x = 7,43 + 0,63 = 8,06 \text{ cm}^4$$

Use ETEM Catalogue to choose the appropriate transom with

$$I_x \geq 8,06 \text{ cm}^4$$

We choose transom E75300S with  $I_x = 13,91 \text{ cm}^4$   
 and  $I_y = 41,75 \text{ cm}^4$



## TRANSOM SELECTION

### \*Wind load actions:

The required moment of inertia of a transom due to the wind action is given by:

a) triangle load

$$\text{If } \frac{L}{a} \leq 1, I_{ya} \geq \frac{w \cdot (L/2) \cdot L^4 \cdot 10^8}{120 \cdot E_{al} \cdot f_{max}}, \text{cm}^4$$

or

b) trapezoid load

$$\text{If } \frac{L}{a} > 1, I_{ya} \geq \frac{w \cdot (a/2) \cdot L^4}{1920 \cdot E_{al} \cdot f_{max}} \cdot 10^8 \cdot \left[ 25 - 40 \cdot \frac{(a/2)^2}{L^2} + 16 \cdot \frac{(a/2)^4}{L^4} \right], \text{cm}^4$$

Use the same method to calculate  $I_{xb}$

Total of required moment of inertia:

$$I_y = I_{ya} + I_{yb}, \text{cm}^4$$

Where:

$I_y$  - Moment of inertia of a transom,  $\text{cm}^4$

$w$  - Wind pressure,  $\text{kg/m}^2$

$E_{al}$  - Modulus of Elasticity of aluminium,  $\text{kg/m}^2$

$f_{max}$  - Maximum transom deflection, m

$L$  - Length of a transom, m

$a, b$  - Distance between transoms, m

Maximum transom deflection  $f_{max}$  by wind load:

$$f = \frac{L}{200}, \text{m} \text{ or } 0,015 \text{ m - whichever is less (EN 14351-1)}$$

Use ETEM Catalogue to choose the appropriate transom with  $I_x$  exceeding or equal to the required  $I_x$ .

Use ETEM Catalogue to choose the appropriate profile which characteristics exceed or are equal to both calculated values  $I_x$  and  $I_y$ .

Example:

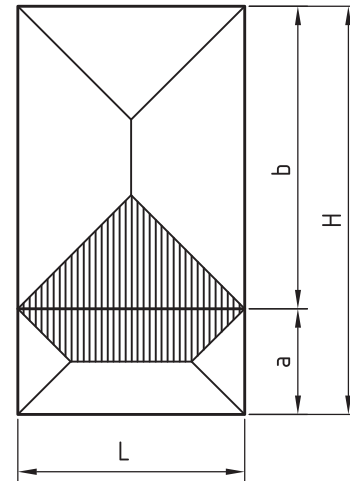

Initial data:

$$L = 1,5 \text{ m}$$

$$w = 60 \text{ kg/m}^2$$

$$a = 0,7 \text{ m}$$

$$E_{al} = 7.10 \text{ kg/m}^2$$

$$b = 2,0 \text{ m}$$

$$f = \frac{L}{200} = \frac{1,5}{200} = 0,0075 \text{ m or } 0,015 \text{ m (EN 14351-1)}$$

$\Rightarrow f_{max} = 0,0075 \text{ m}$  in the following formulas:

$$\frac{L}{a} = \frac{1,5}{0,7} = 2,14 > 1$$

$$I_{ya} \geq \frac{w \cdot (a/2) \cdot L^4}{1920 \cdot E_{al} \cdot f_{max}} \cdot 10^8 \cdot \left[ 25 - 40 \cdot \frac{(a/2)^2}{L^2} + 16 \cdot \frac{(a/2)^4}{L^4} \right], \text{cm}^4$$

$$I_{ya} \geq \frac{60 \cdot (0,7/2) \cdot 1,5^4}{1920 \cdot 7 \cdot 10^9 \cdot 0,0075} \cdot 10^8 \cdot \left[ 25 - 40 \cdot \frac{(0,7/2)^2}{1,5^2} + 16 \cdot \frac{(0,7/2)^4}{1,5^4} \right], \text{cm}^4$$

$$I_{ya} \geq 2,41 \text{ cm}^4$$

$$\frac{L}{b} = \frac{1,5}{2,0} = 0,75 < 1$$

$$I_{yb} \geq \frac{w \cdot (L/2) \cdot L^4 \cdot 10^8}{120 \cdot E_{al} \cdot f_{max}}, \text{cm}^4 \Rightarrow I_{yb} \geq \frac{60 \cdot (1,5/2) \cdot 1,5^4 \cdot 10^8}{120 \cdot 7 \cdot 10^9 \cdot 0,0075}, \text{cm}^4$$

$$\Rightarrow I_{yb} \geq 3,62 \text{ cm}^4$$

$$I_y = I_{ya} + I_{yb}, \text{cm}^4$$

$$\Rightarrow I_y = 2,41 + 3,62 = 6,03 \text{ cm}^4$$

Use ETEM Catalogue to choose the appropriate mullion with

$$I_y \geq 6,03 \text{ cm}^4$$

We choose mullion E75300S with  $I_x = 13,91 \text{ cm}^4$   
and  $I_y = 41,75 \text{ cm}^4$

## CALCULATION OF GLASS PANE THICKNESS

### \*Glazing thickness:

For single glazing the minimum thickness is given by the following equations:

$$\text{a) If } \frac{h_g}{l_g} \leq 3, t = \sqrt{\frac{10 \cdot l_g \cdot h_g \cdot w}{72}}, \text{mm}$$

or

$$\text{b) If } \frac{h_g}{l_g} > 3, t = \frac{l_g \cdot \sqrt{10 \cdot w}}{72}, \text{mm}$$

Where:

$t$  - Minimum theoretical glass thickness, mm

$w$  - Wind pressure,  $\text{kg/m}^2$

$l_g$  - The smallest dimension of the glass pane, m

$h_g$  - The largest dimension of the glass pane, m

For double glazing, the total thickness of both glasses in the panel is equal to the thickness of a single glass pane (evaluated using the above equations) multiplied by 1.5

For triple glazing, the total thickness of all glasses in the panel is equal to the thickness of a single glass pane (evaluated using the above equations) multiplied by 1.7

Always consult facade engineer or glazing manufacturer when calculating for required glazing thickness and maximum allowable dimensions.

Example:

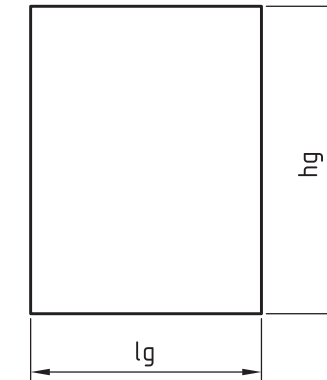

Initial data:

$$l_g = 1,5 \text{ m}$$

$$h_g = 2,0 \text{ m}$$

$$w = 60 \text{ kg/m}^2$$

$$\frac{h_g}{l_g} = \frac{2}{1,5} = 1,33 \leq 3$$

$$t = \sqrt{\frac{10 \cdot l_g \cdot h_g \cdot w}{72}} = \sqrt{\frac{10 \cdot 1,5 \cdot 2 \cdot 60}{72}} = \sqrt{\frac{1800}{72}} = 5 \text{ mm}$$

For double glazing  $t_{req} = 1,5 \cdot 5 = 7,5 \text{ mm}$

We choose double glazing 5/14/5

## GLAZING SHIMS

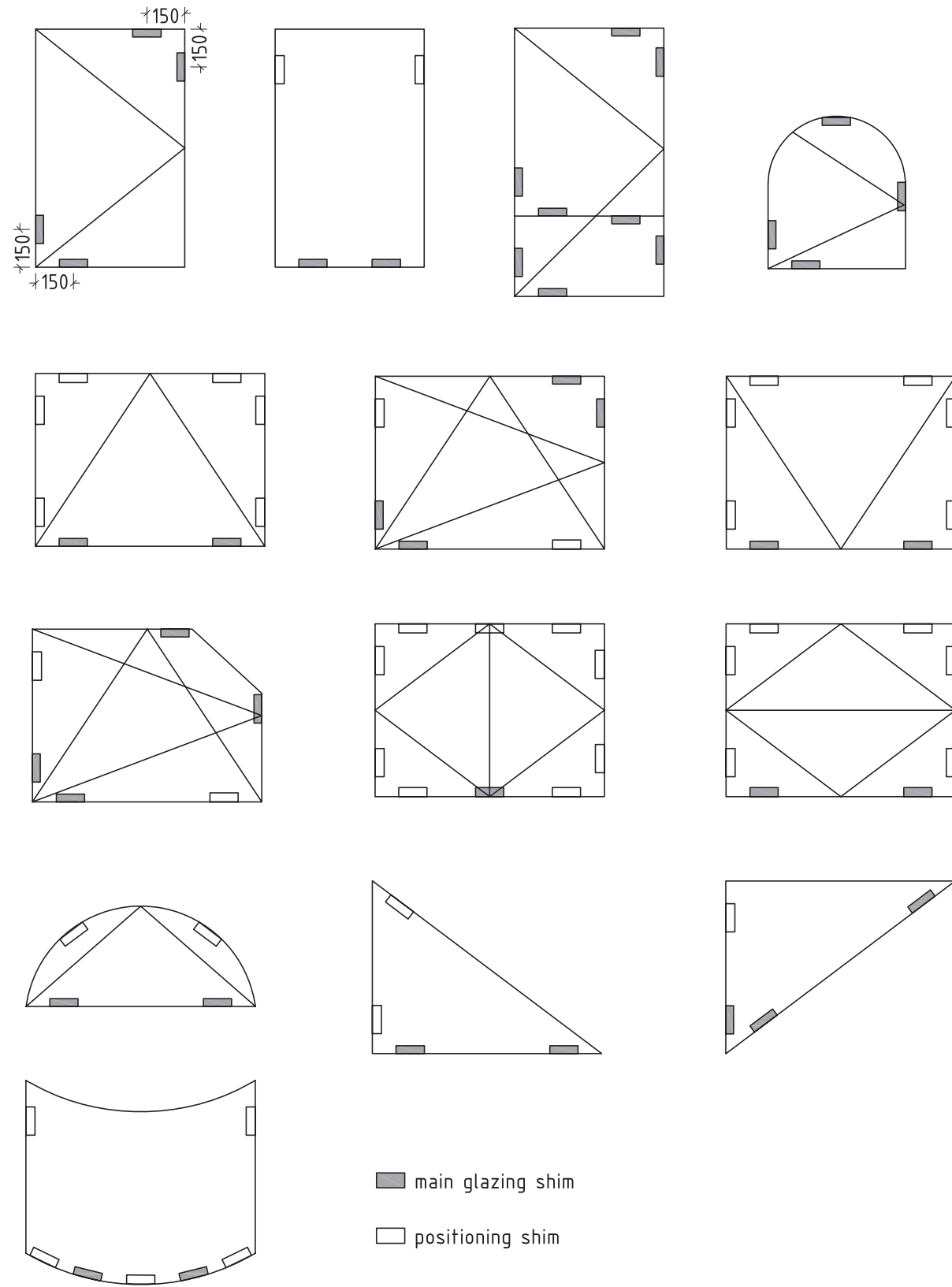

Note:  
Main glazing shims should be positioned on 150 mm distance from the glazing edge.  
Positioning shims do not have exactly defined position.

## POSITION OF ANCHORS

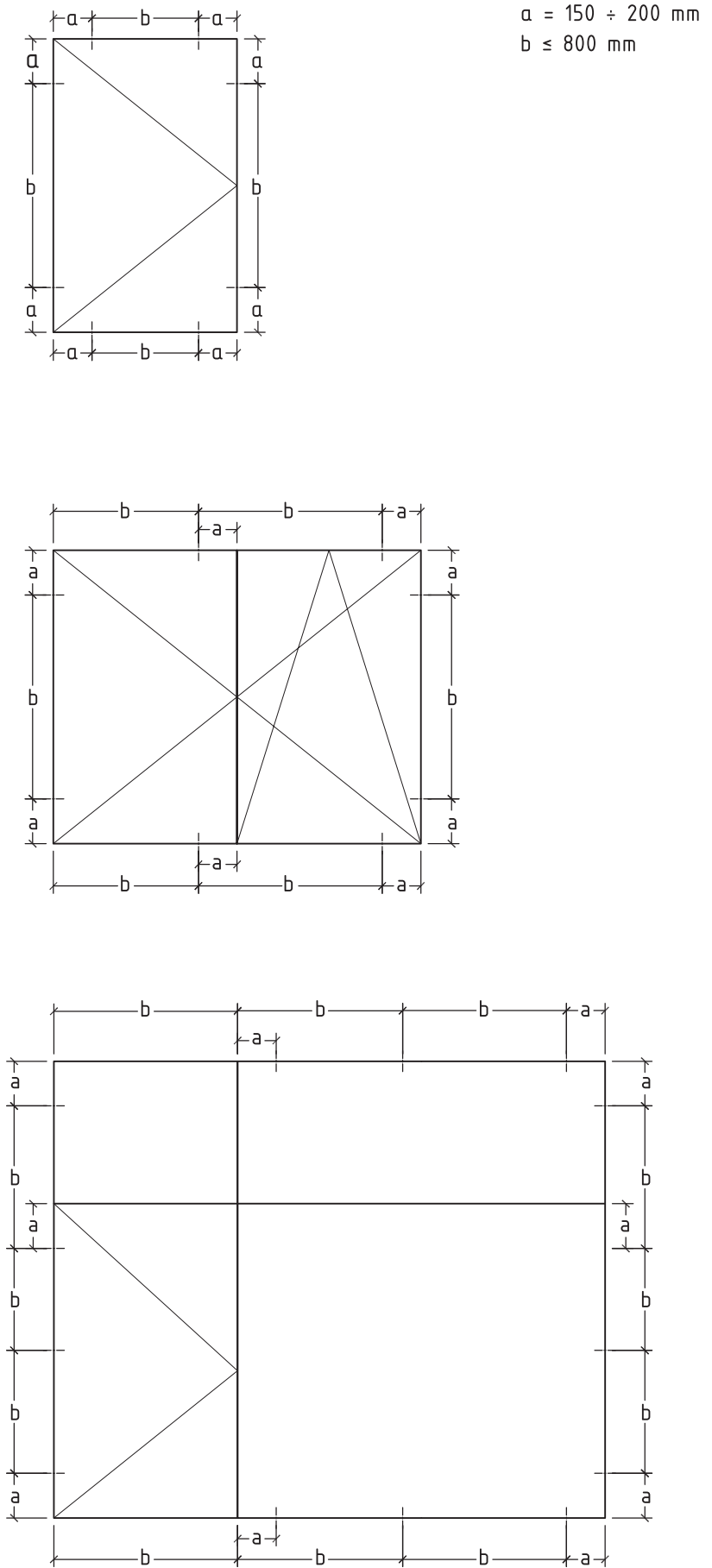

## METHOD FOR CALCULATION OF THERMAL TRANSMITTANCE ACCORDING to EN ISO 10077-2

$$U_w = \frac{A_g \times U_g + A_f \times U_f + l_g \times \Psi_g}{A_g + A_f} \quad (1)$$

- $U_w$  - thermo-transmittance coefficient of the whole structure
- $U_g$  - glass thermal transmittance coefficient
- $U_f$  - thermo-transmittance coefficient of the aluminium frame (frame and sash)
- $\Psi_g$  - spacer linear thermal transmittance
- $l_g$  - total length of the spacer
- $A_g$  - glass area
- $A_f$  - aluminium frame area (frame and sash)

- $U_w$  - is calculated by formula (1)
- $U_g$  - is given by the glass manufacturer
- $U_f$  - is given by the manufacturer of the aluminium profiles

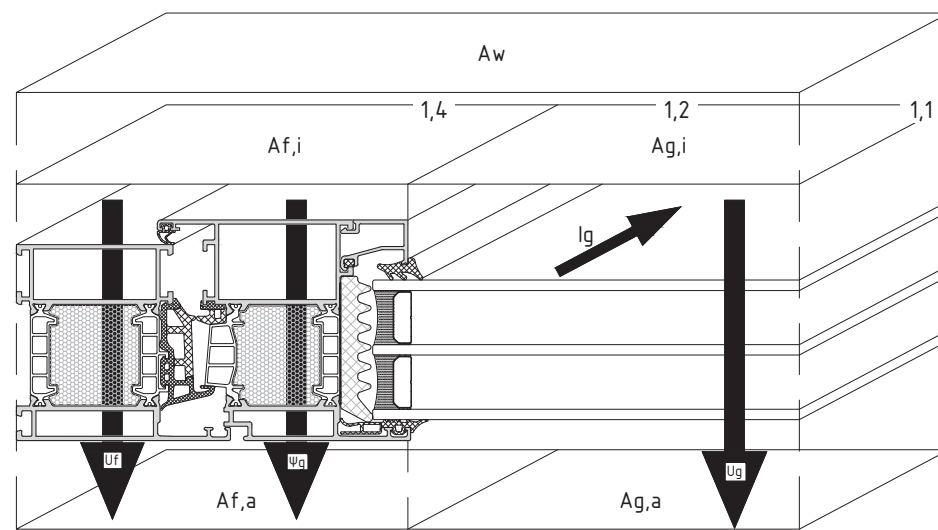

0,8

### EXAMPLE FOR CALCULATING THERMAL TRANSMITTANCE COEFFICIENT

frame:	E75	$U_f$	1.34	$W/(m^2K)$
spacer:	warm edge	$\Psi_g$	0.051	$W/(m^2K)$
glass:	triple glazing	$U_g$	1.00	$W/(m^2K)$
window width:	1.00 m			
window height:	2.00 m			
length of glass edge $l_g$ :	4,89 m			
$A_g = 1.24 \text{ m}^2$ ; $A_f = 0.76 \text{ m}^2$				

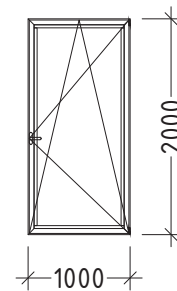

$$U_w = \frac{1.24 \times 1 + 0.76 \times 1.34 + 4.89 \times 0.051}{1.24 + 0.76}$$

$$U_w \approx 1,3 \text{ W/(m}^2\text{K)}$$

# E75FD

# FLAT DOOR SYSTEM WITH THERMAL BREAK

# GENERAL INFORMATION

CONCEPT / ADVANTAGES / CERTIFICATES

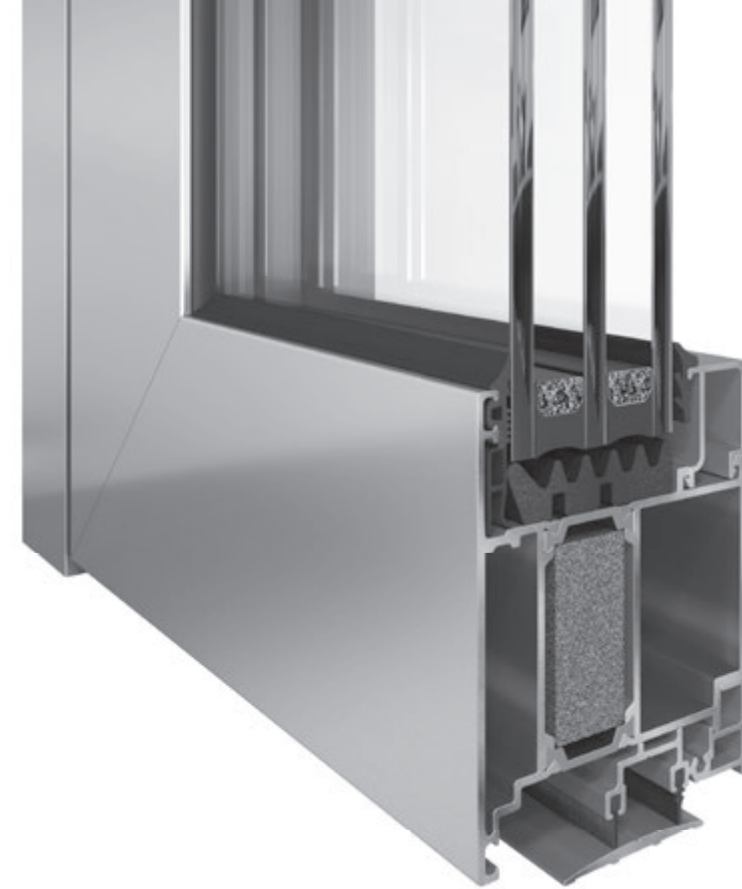

# E75FD CONCEPT

**E75FD** WINDOW IS A SYSTEM CORRESPONDING TO THE MOST STRINGENT REQUIREMENTS FOR THERMAL INSULATION, FUNCTIONALITY AND AESTHETICS.

- Elegant straight design
- 75 mm system width allowing usage of triple glazing
- Wide polyamide bars
- Excellent thermal insulation from 1,1 W/m<sup>2</sup>.K
- Additional insulator in the thermo-break area
- Additional insulator under the glass
- Effective drainage
- Excellent water-tightness and air-permeability
- Co-extruded central gasket
- Possibility for mounting anti-burglar hardware for good security performance
- Extruded corners for crimping machine with glue allowing greater connections

## ADVANCED SYSTEM

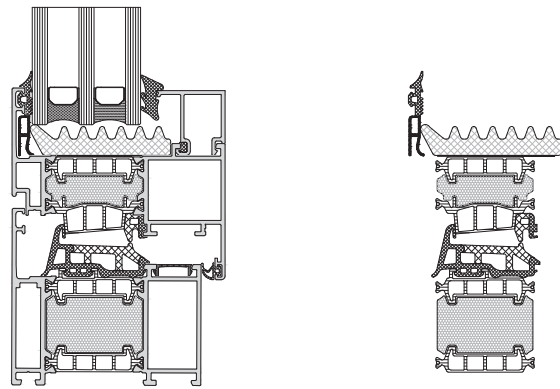

## BASIC SYSTEM

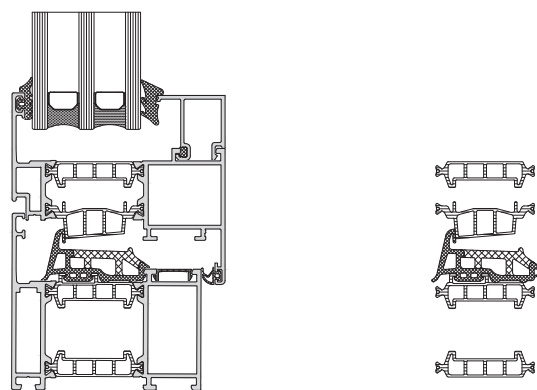

# TABLES

TYOLOGIES / LIST OF PROFILES / CHARACTERISTICS

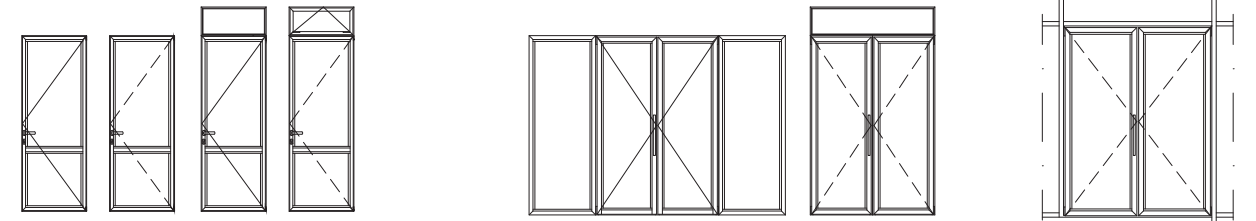

# flat door system with thermal break

E75FD

code	profile	length weight moment of inertia	code	profile	length weight moment of inertia
E75110 frame-inward		L=6.01 m 1932 g/m Ix=27.25 cm <sup>4</sup> Iy=49.95 cm <sup>4</sup>	E75120 kick plate		L=6.01 m 1899 g/m Ix=32.42 cm <sup>4</sup> Iy=55.04 cm <sup>4</sup>
E75111 frame-outward		L=6.01 m 1891 g/m Ix=26.58 cm <sup>4</sup> Iy=49.88 cm <sup>4</sup>	E75121 kick plate		L=6.01 m 2304 g/m Ix=68.11 cm <sup>4</sup> Iy=67.91 cm <sup>4</sup>
E75210 sash-inward		L=6.01 m 2063 g/m Ix=36.18 cm <sup>4</sup> Iy=54.04 cm <sup>4</sup>	E75304 T profile		L=6.01 m 2427 g/m Ix=68.51 cm <sup>4</sup> Iy=66.9 cm <sup>4</sup>
E75211 sash-outward		L=6.01 m 2073 g/m Ix=36.3 cm <sup>4</sup> Iy=52.06 cm <sup>4</sup>	E75605 adapter		L=6.01 m 274 g/m
E4275606 alignment profile		120 g/m L=6.01 m	E75112 reverse profile		L=6.01 m 1164 g/m Ix=5.14 cm <sup>4</sup> Iy=22.84 cm <sup>4</sup>
E75103 frame		L=6.01 m 2228 g/m Ix=57.75 cm <sup>4</sup> Iy=62.95 cm <sup>4</sup>	E75601 adapter for facade		L=6.01 m 897 g/m Ix=152 cm <sup>4</sup> Iy=10.95 cm <sup>4</sup>

L75D-01

# flat door system with thermal break

E75FD

code	profile	length weight moment of inertia	code	profile	length weight moment of inertia
E75602 adapter		L=6.01 m 216 g/m	E75801 adapter		L=6.01 m 85 g/m
E75603 round column		L=6.01 m 2232 g/m Ix=56.34 cm <sup>4</sup> Iy=55.75 cm <sup>4</sup>	E75805 bottom rail		L=6.01 m 210 g/m
E75810 door threshold		L=6.01 m 722 g/m			
E75811 door threshold		L=6.01 m 723 g/m			
E75800 brush-holder		L=6.01 m 497 g/m			
E75802 bottom rail		L=6.01 m 85 g/m			

L75D-02



# PROFILES

DRAWINGS

E 75110  
frame-inward  
1932 g/m

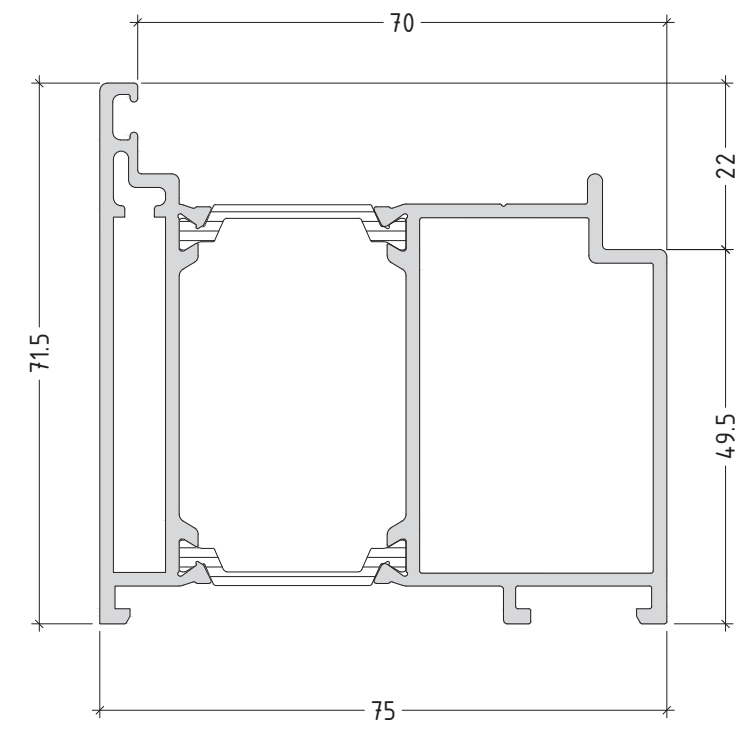

E 75111  
frame-outward  
1891 g/m

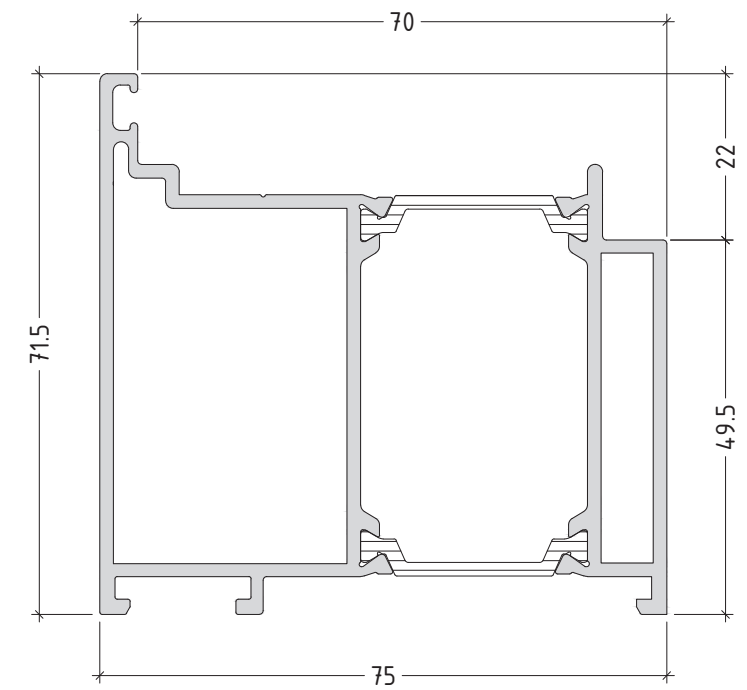

scale : 1:1

flat door system with thermal break

E75FD

E75210  
sash-inward  
2063 g/m

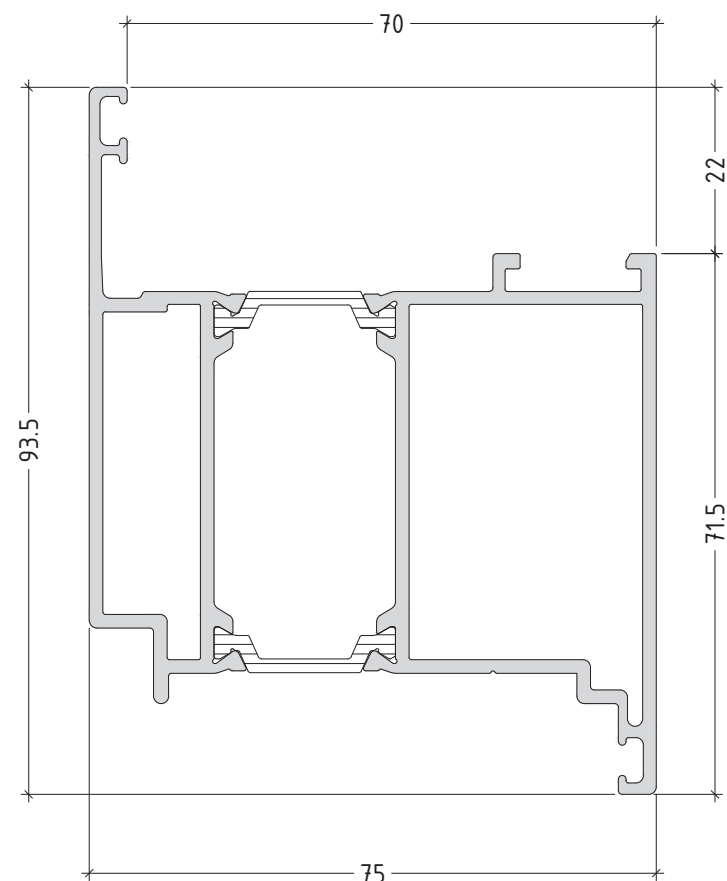

E75211  
sash-outward  
2073 g/m

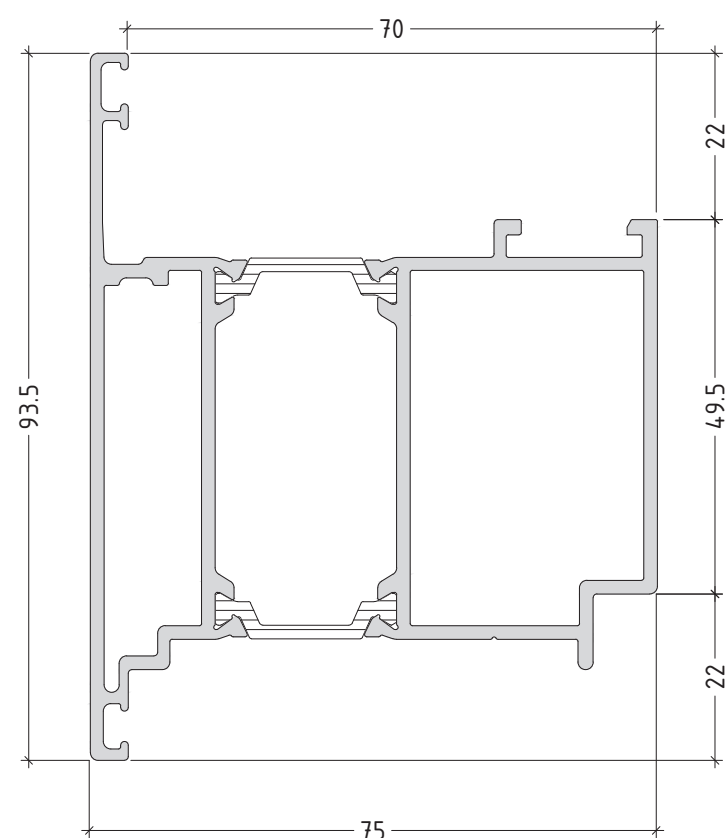

scale : 1:1

P75D-02

flat door system with thermal break

E75FD

E4275606  
120 g/m

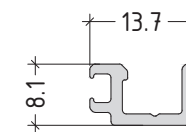

E75103  
2224 g/m

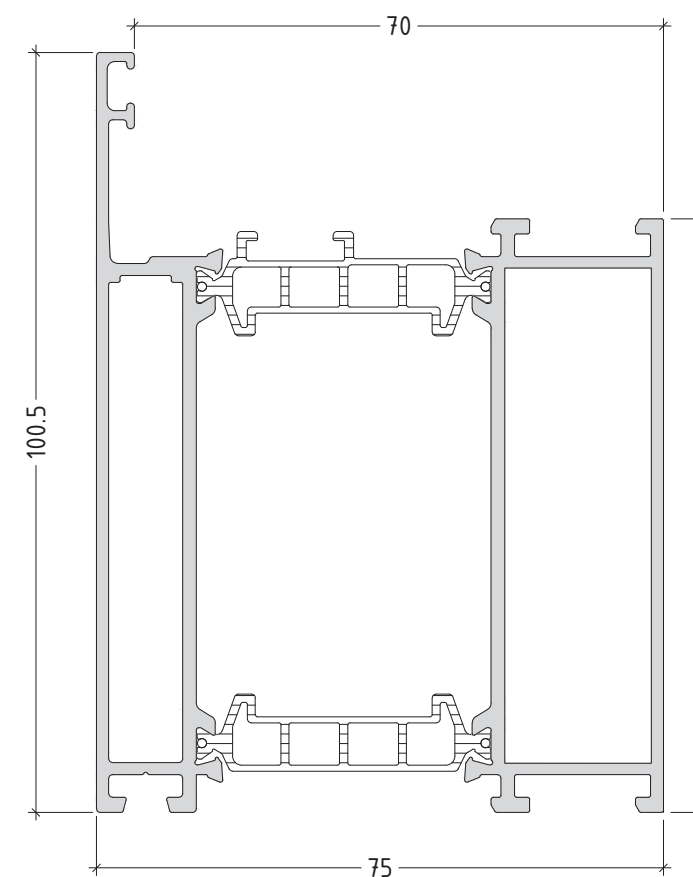

scale : 1:1

P75D-03

flat door system with thermal break

E75FD

E75120  
1899 g/m

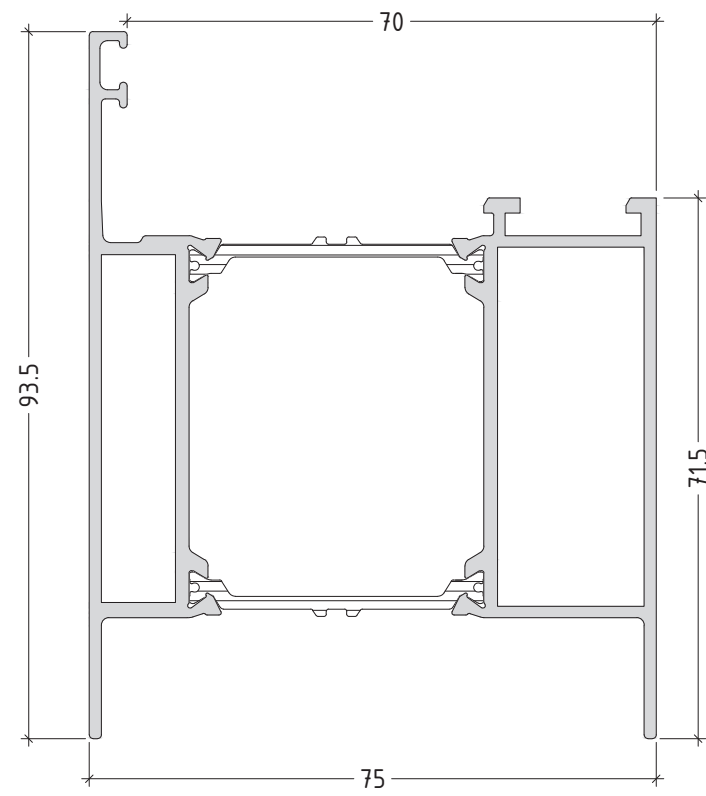

scale : 1:1

P75D-04

flat door system with thermal break

E75FD

E75121  
2304 g/m

E75304  
2427 g/m

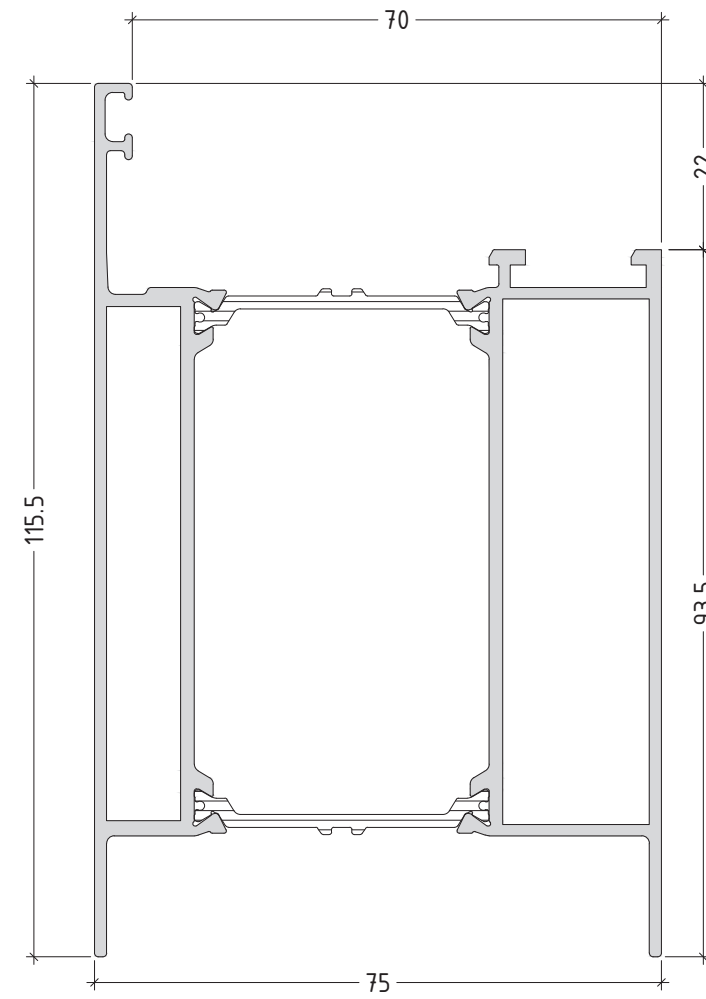

scale : 1:1

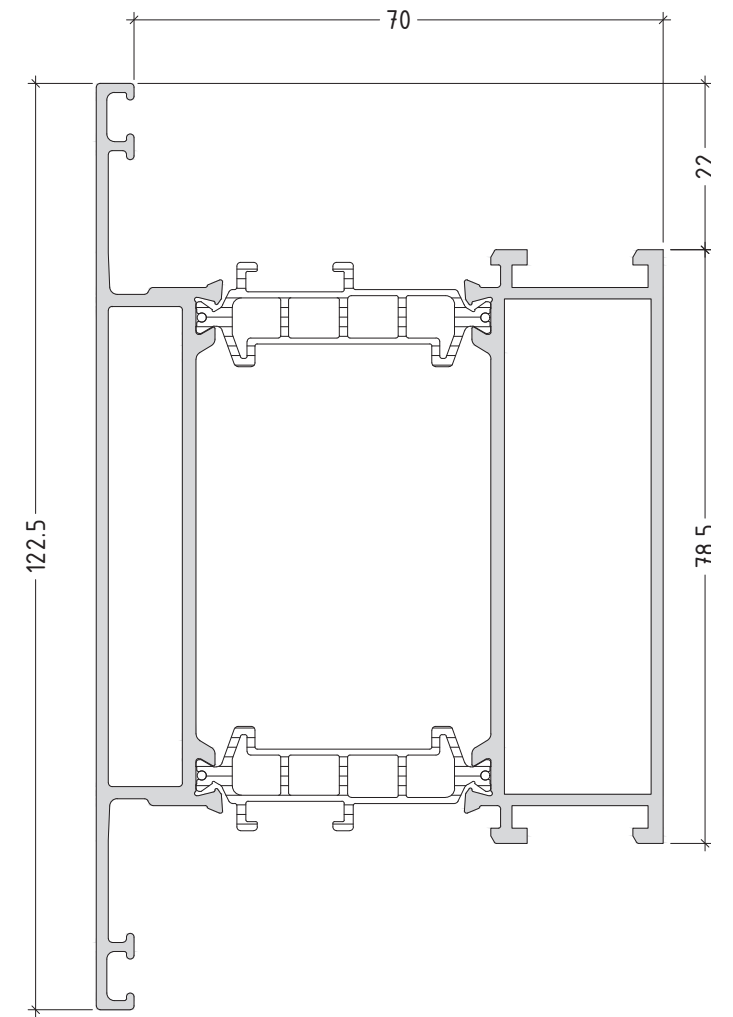

P75D-05

E75605  
274 g/m

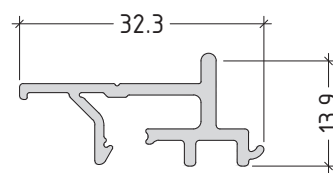

E75112  
1164 g/m

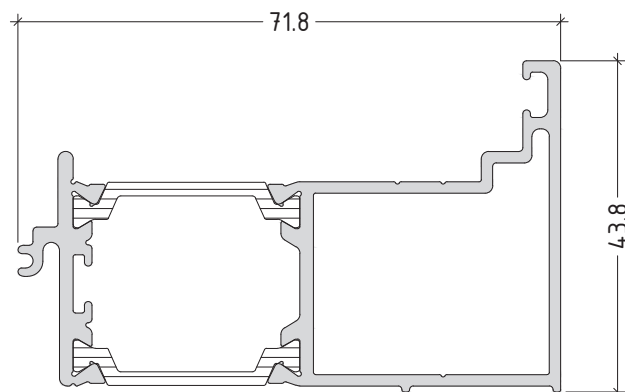

E75601  
adapter for facade  
897 g/m

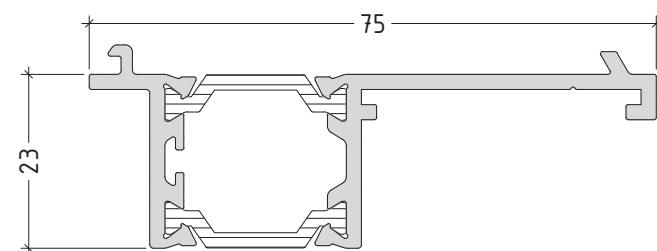

scale : 1:1

P75D-06

E75602  
216 g/m

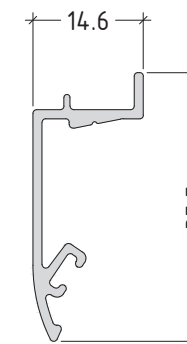

E75603  
2232 g/m

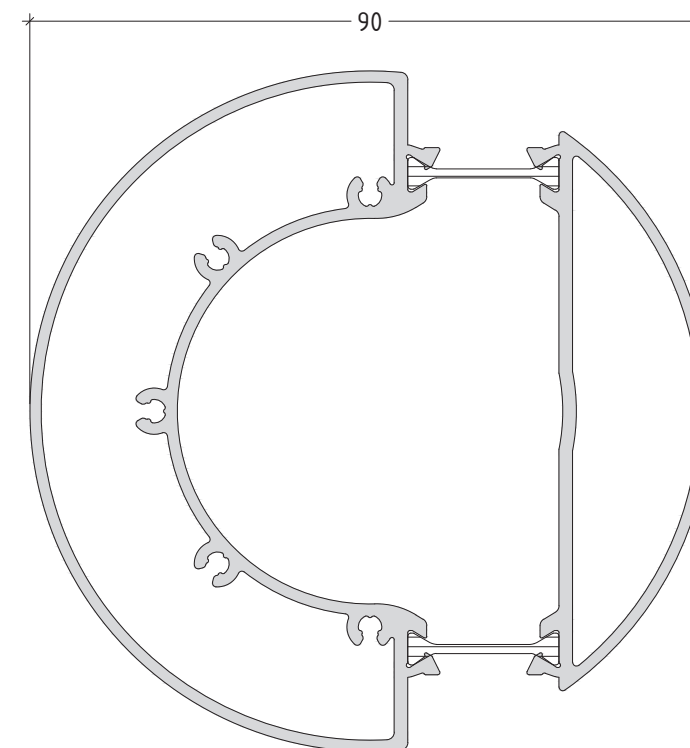

scale : 1:1

P75D-07

E75810  
722 g/m

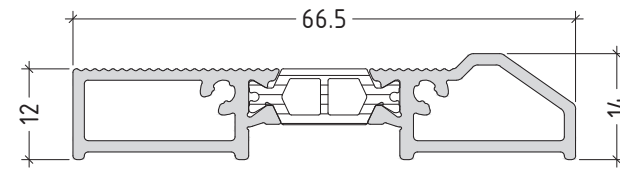

E75811  
723 g/m

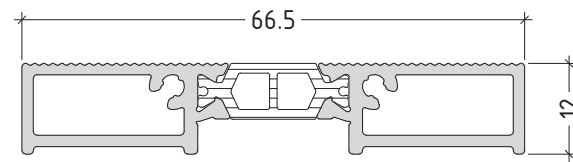

E75805  
210 g/m

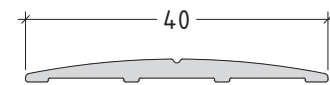

E75800  
brush-holder  
497 g/m

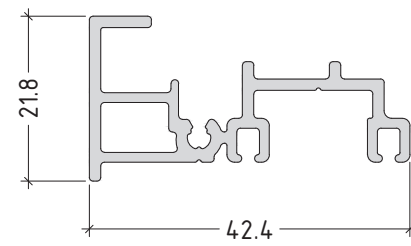

E75802  
85 g/m

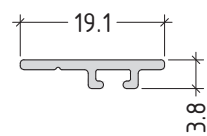

E75801  
85 g/m

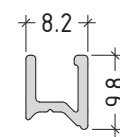

scale : 1:1

P75D-08

# SECTIONS

SECTIONS / DETAILS

outward opening

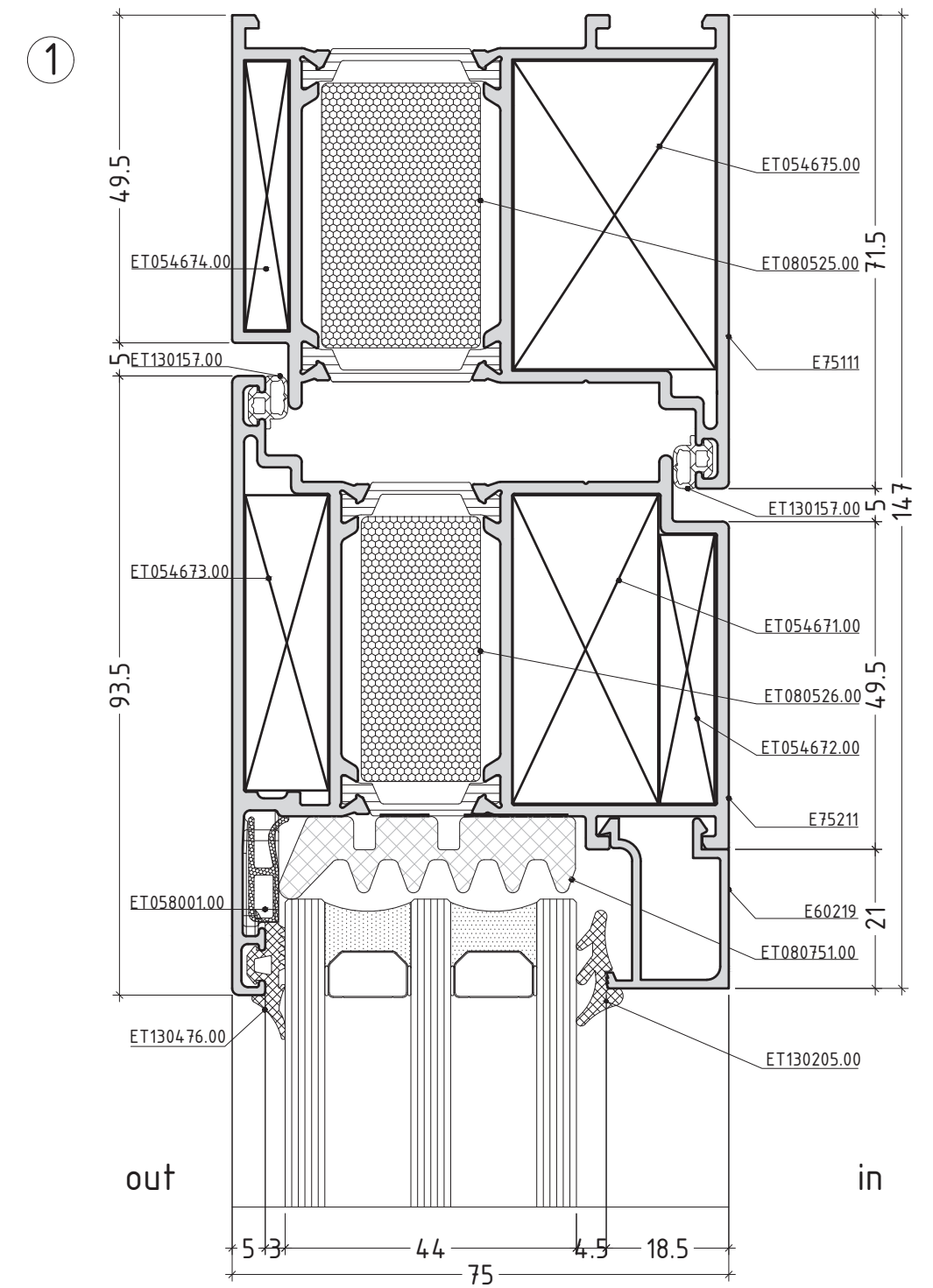
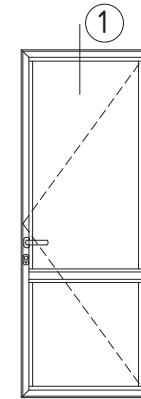

scale : 1:1

flat door system with thermal break

E75FD

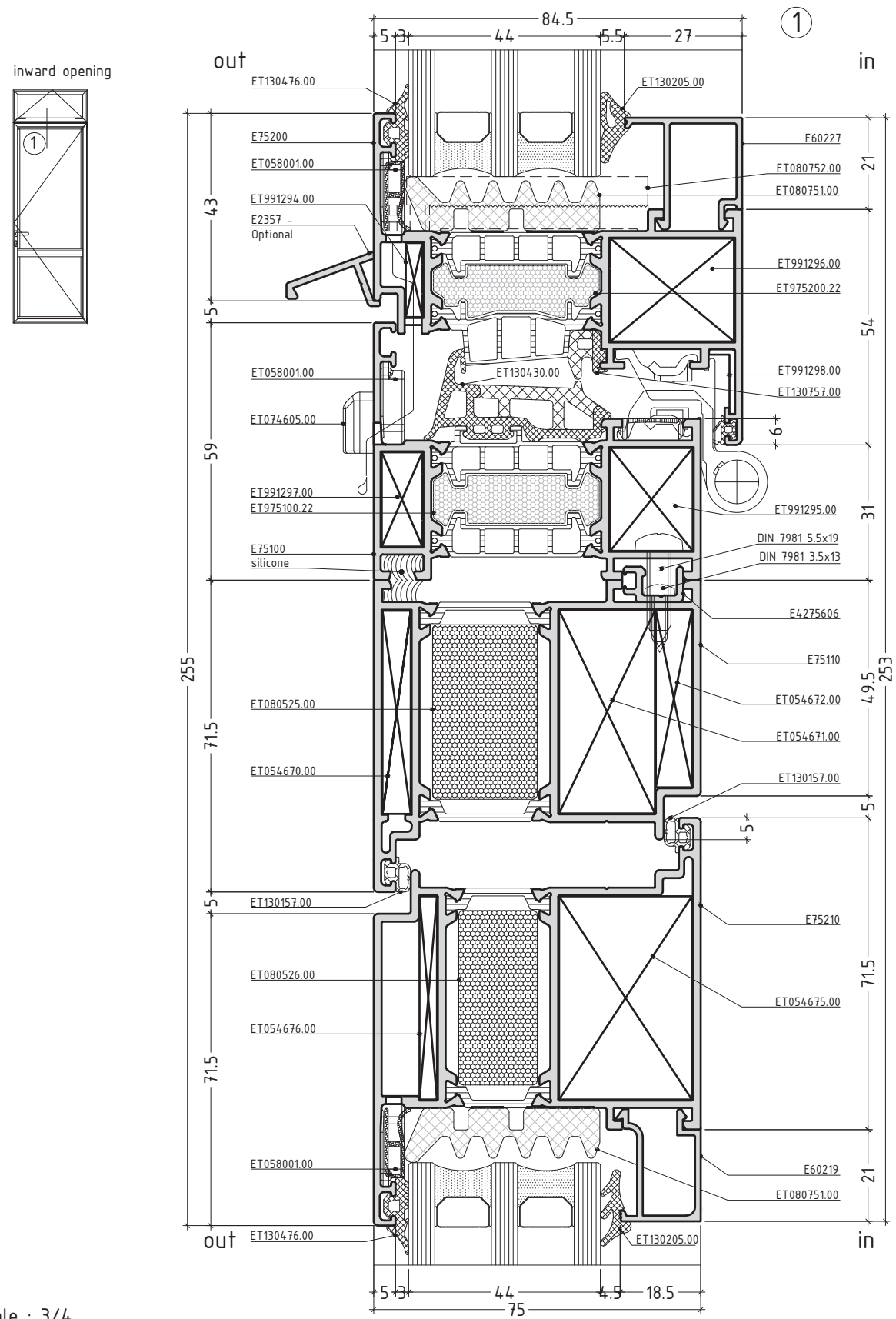

scale : 3/4

D75-2

flat door system with thermal break

E75FD

inward opening

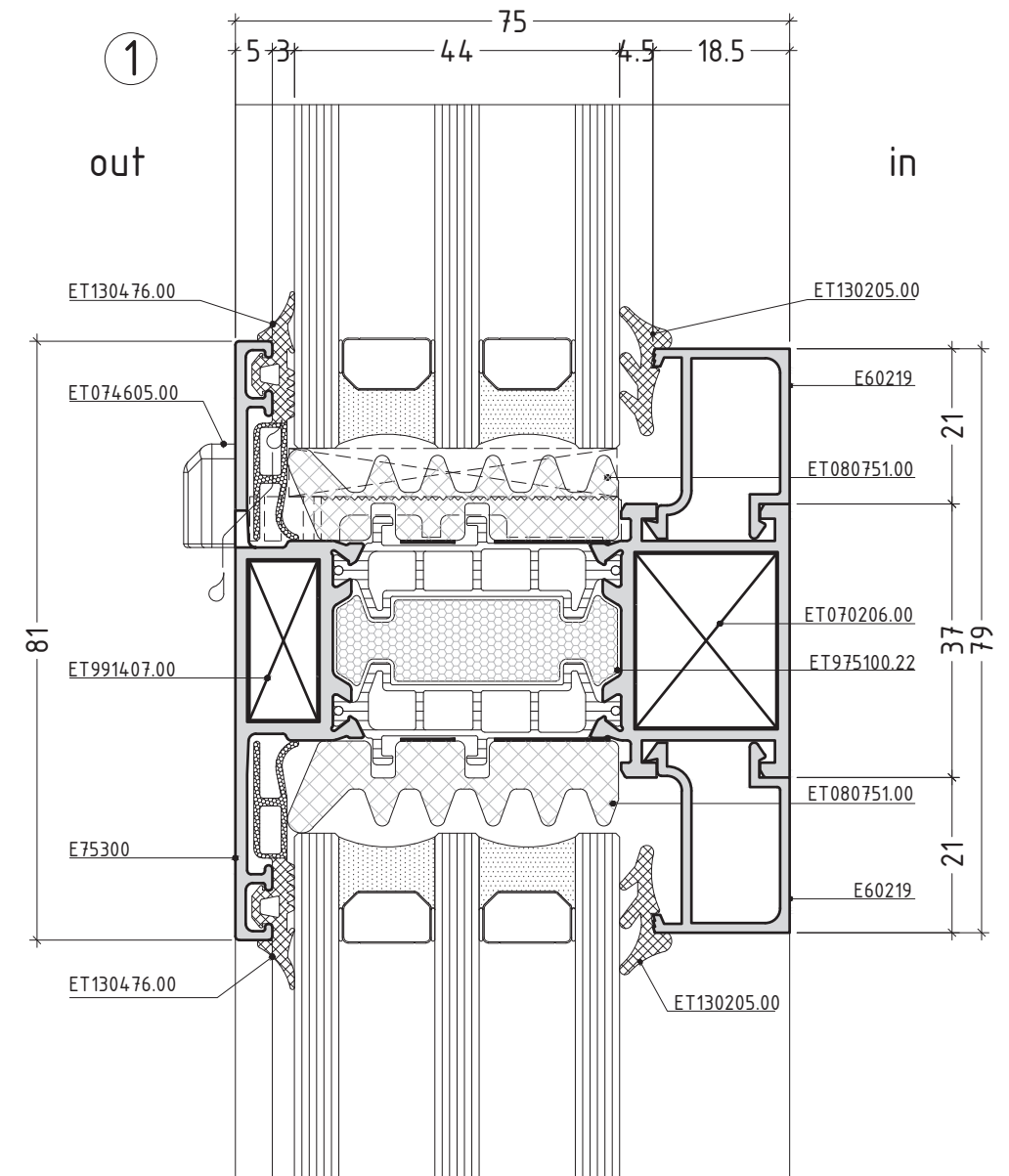
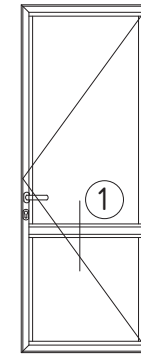

scale : 1:1

D75-3



flat door system with thermal break

E75FD

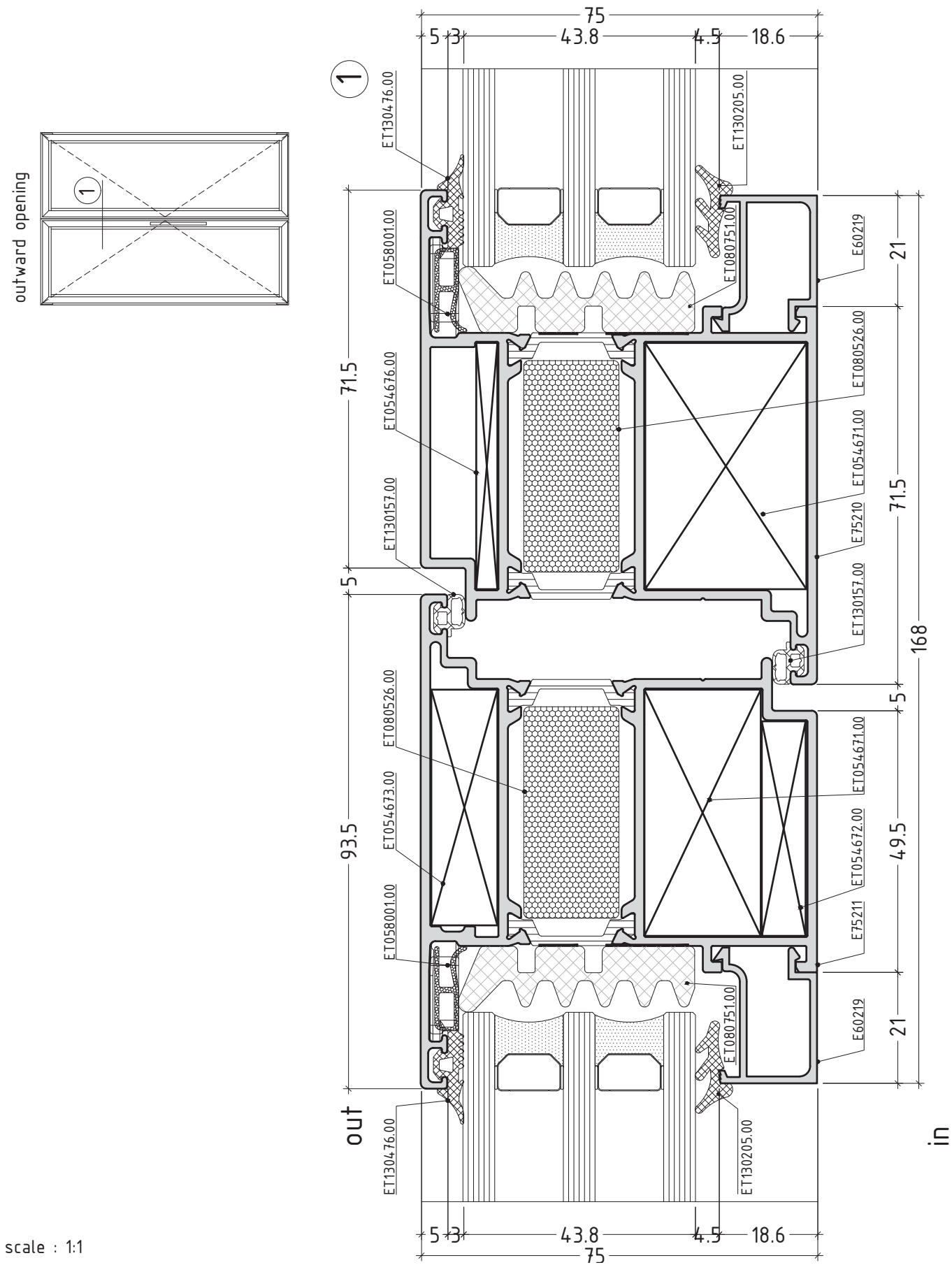

scale : 1:1

D75-4

flat door system with thermal break

E75FD

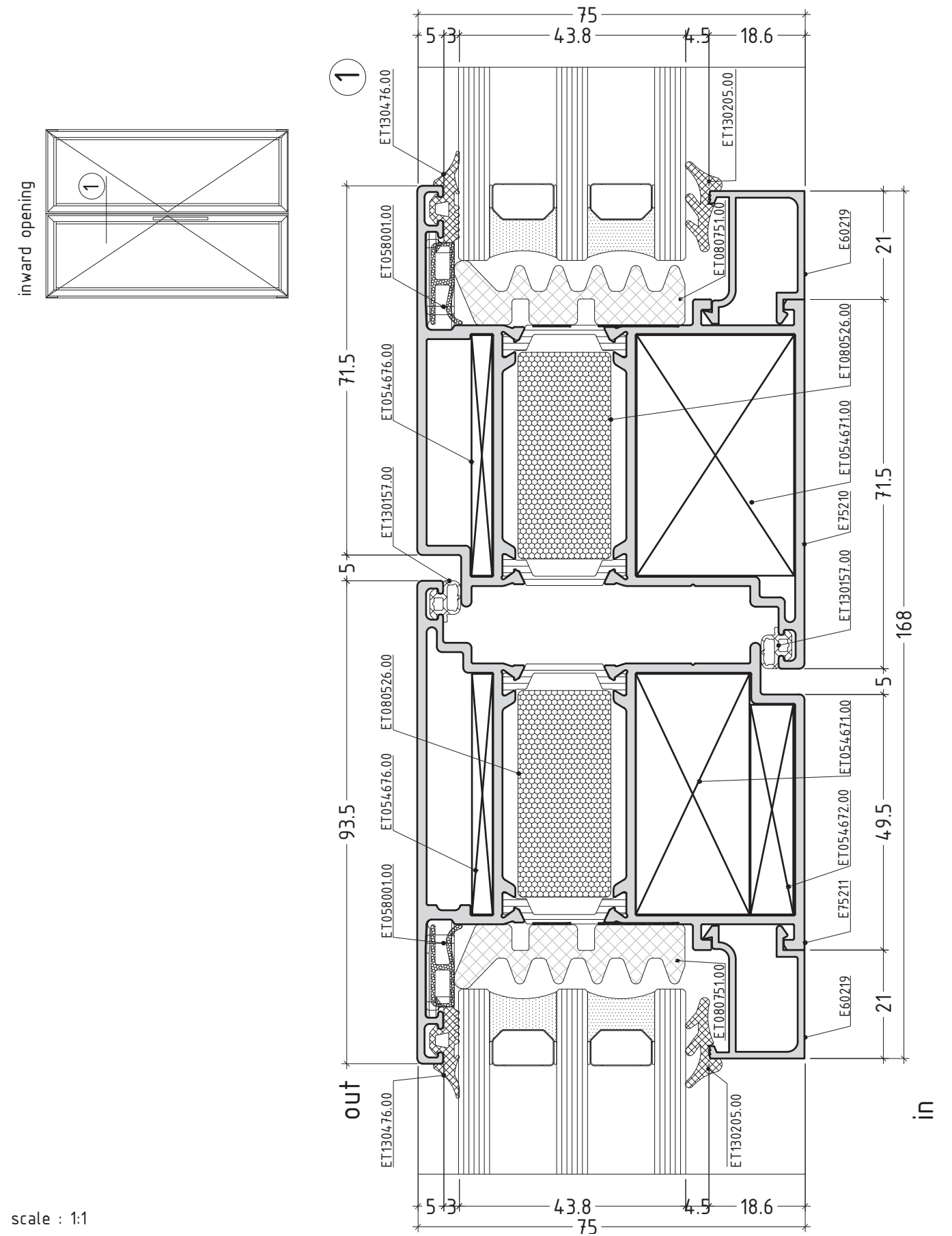

scale : 1:1

D75-4.1

flat door system with thermal break

E75FD

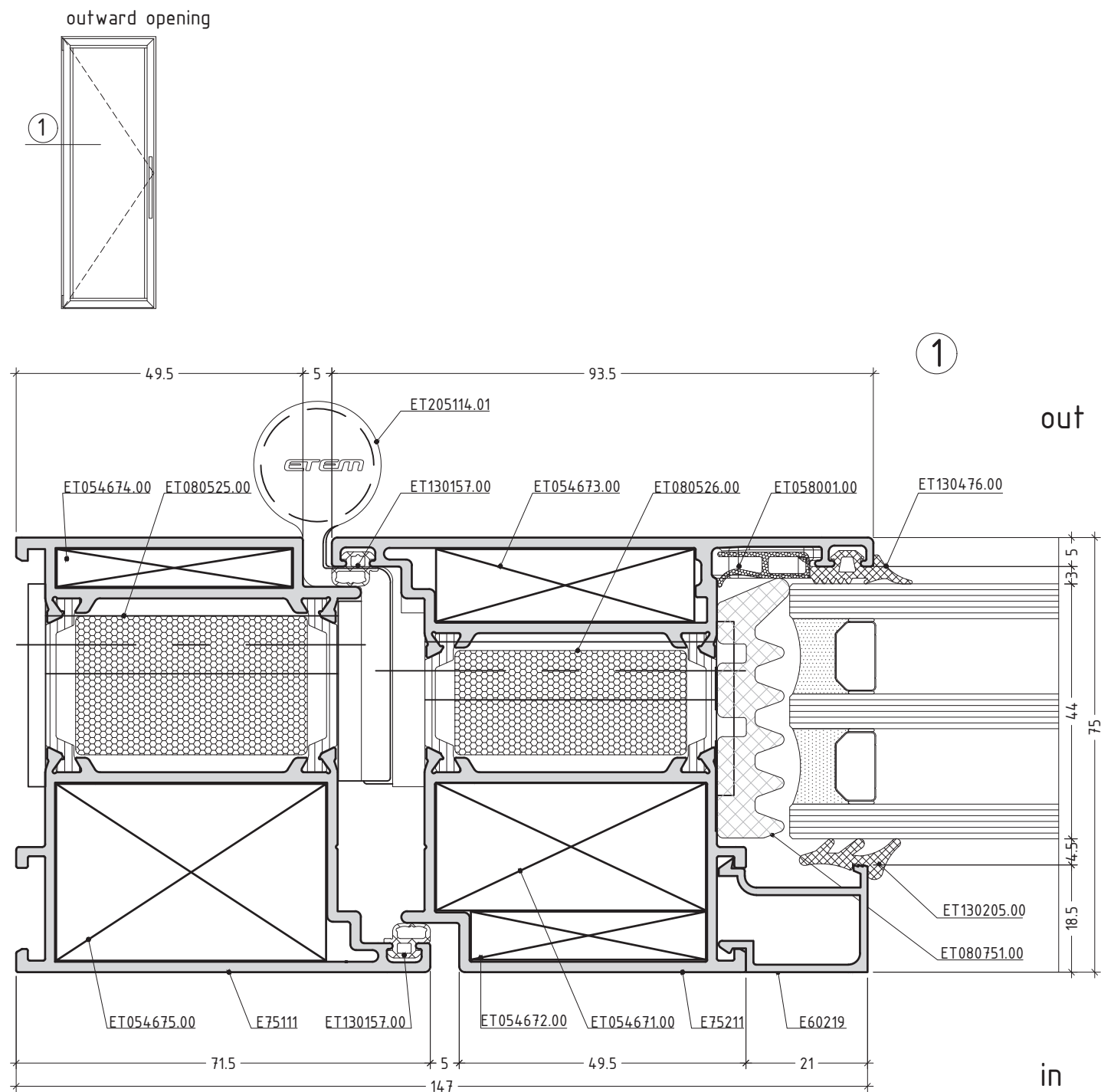

scale : 1:1

D75-5

flat door system with thermal break

E75FD

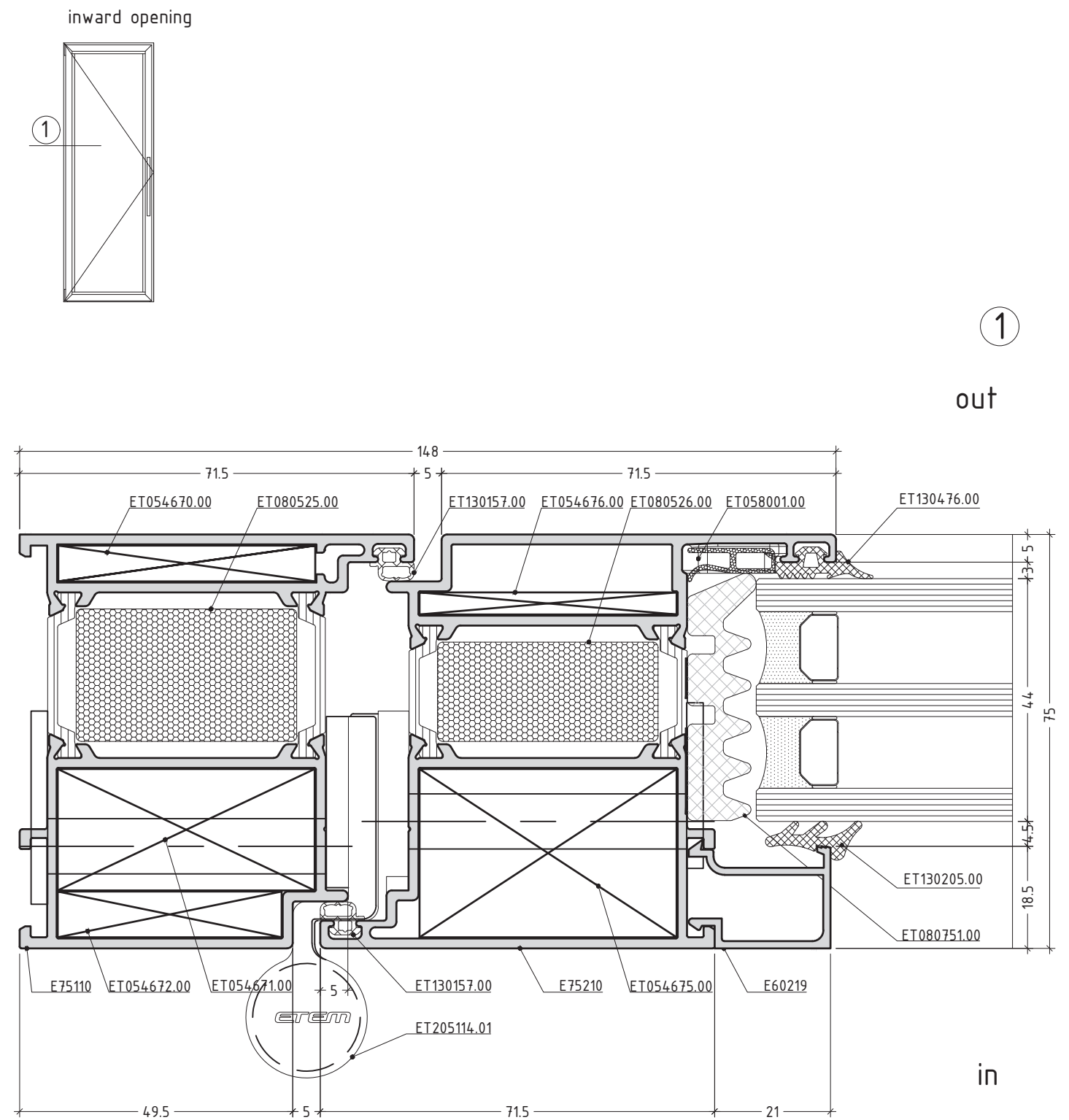

scale : 1:1

D68-6

flat door system with thermal break

E75FD

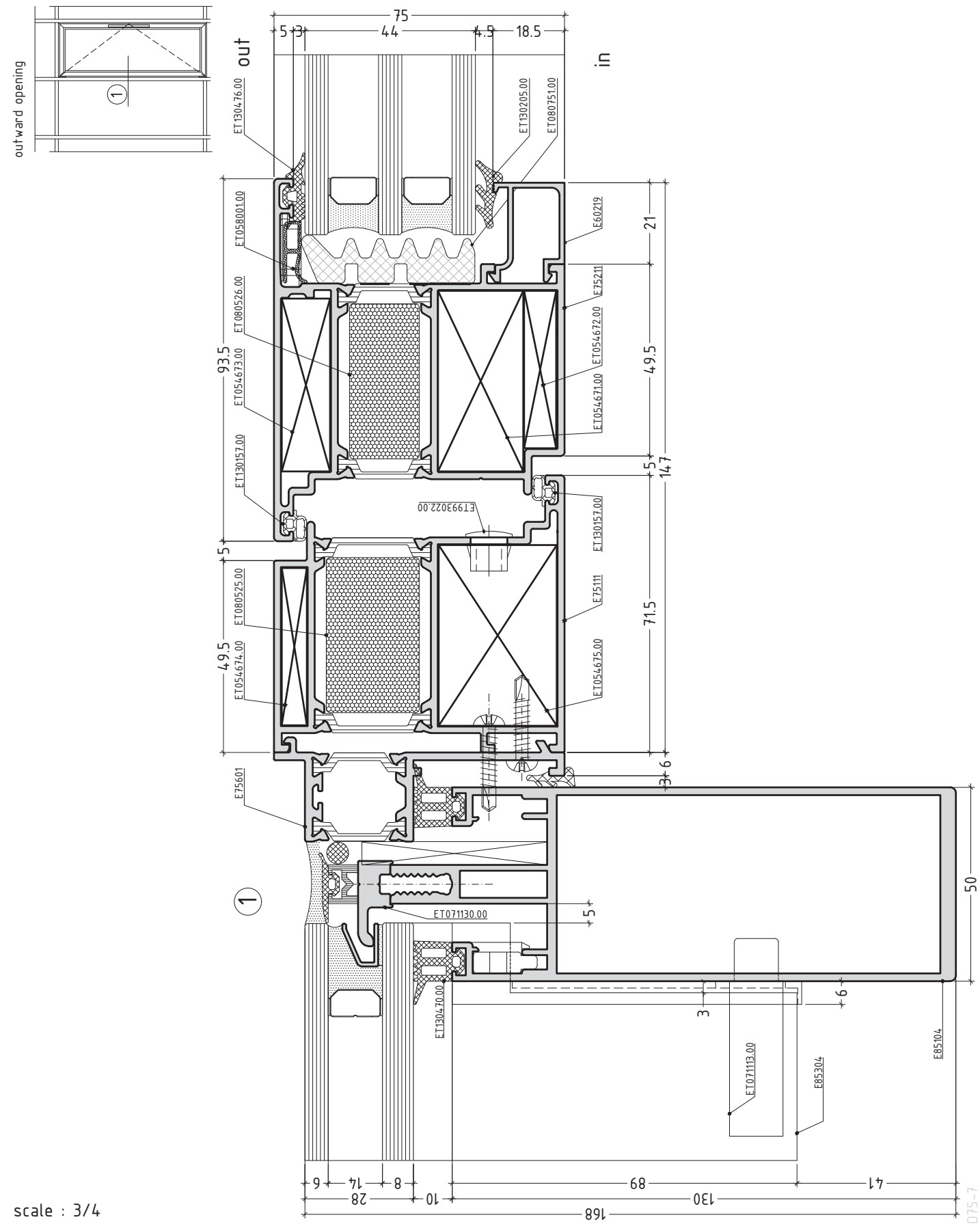

scale : 3/4

flat door system with thermal break

E75FD

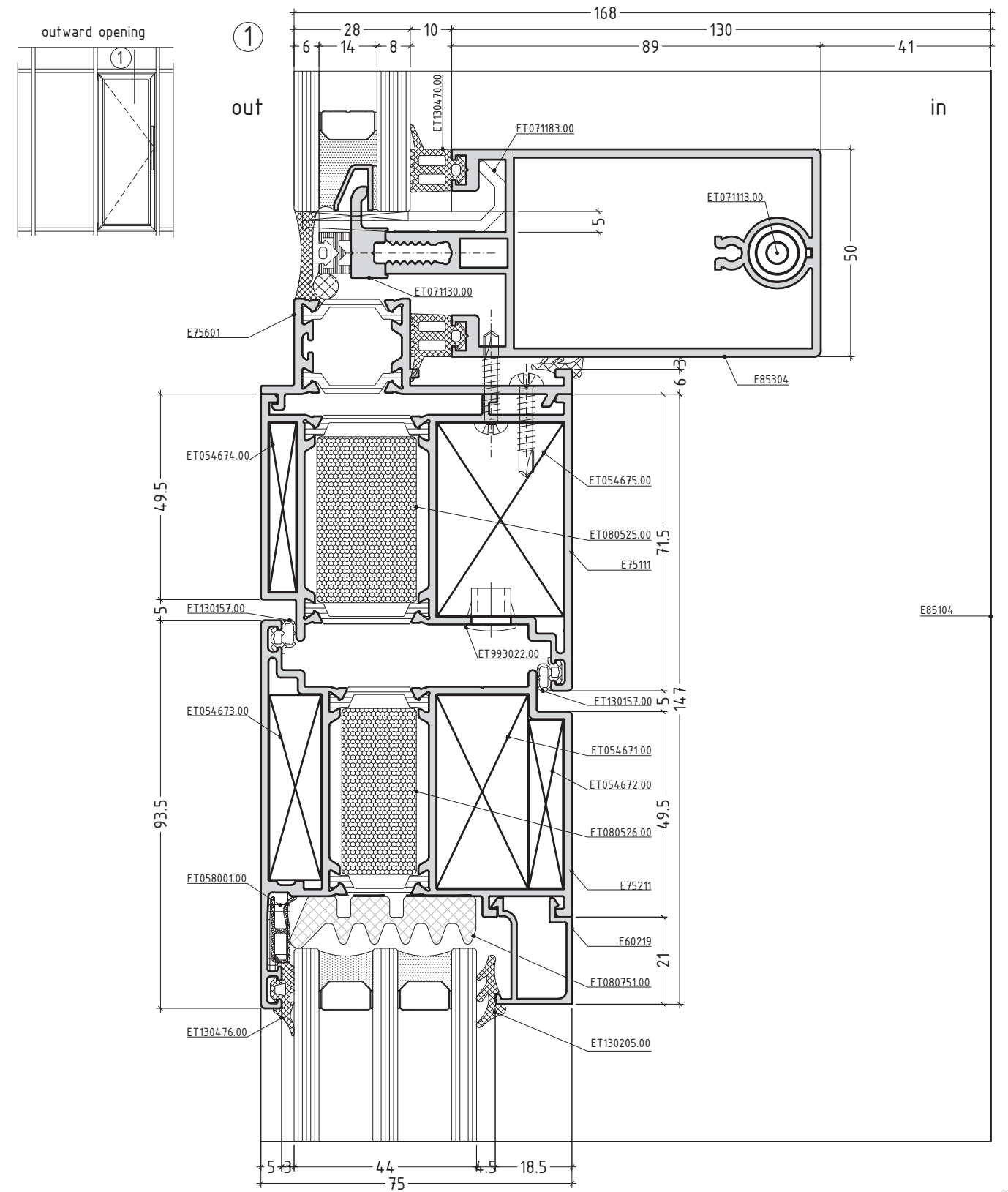

scale : 3/4

flat door system with thermal break

E75FD

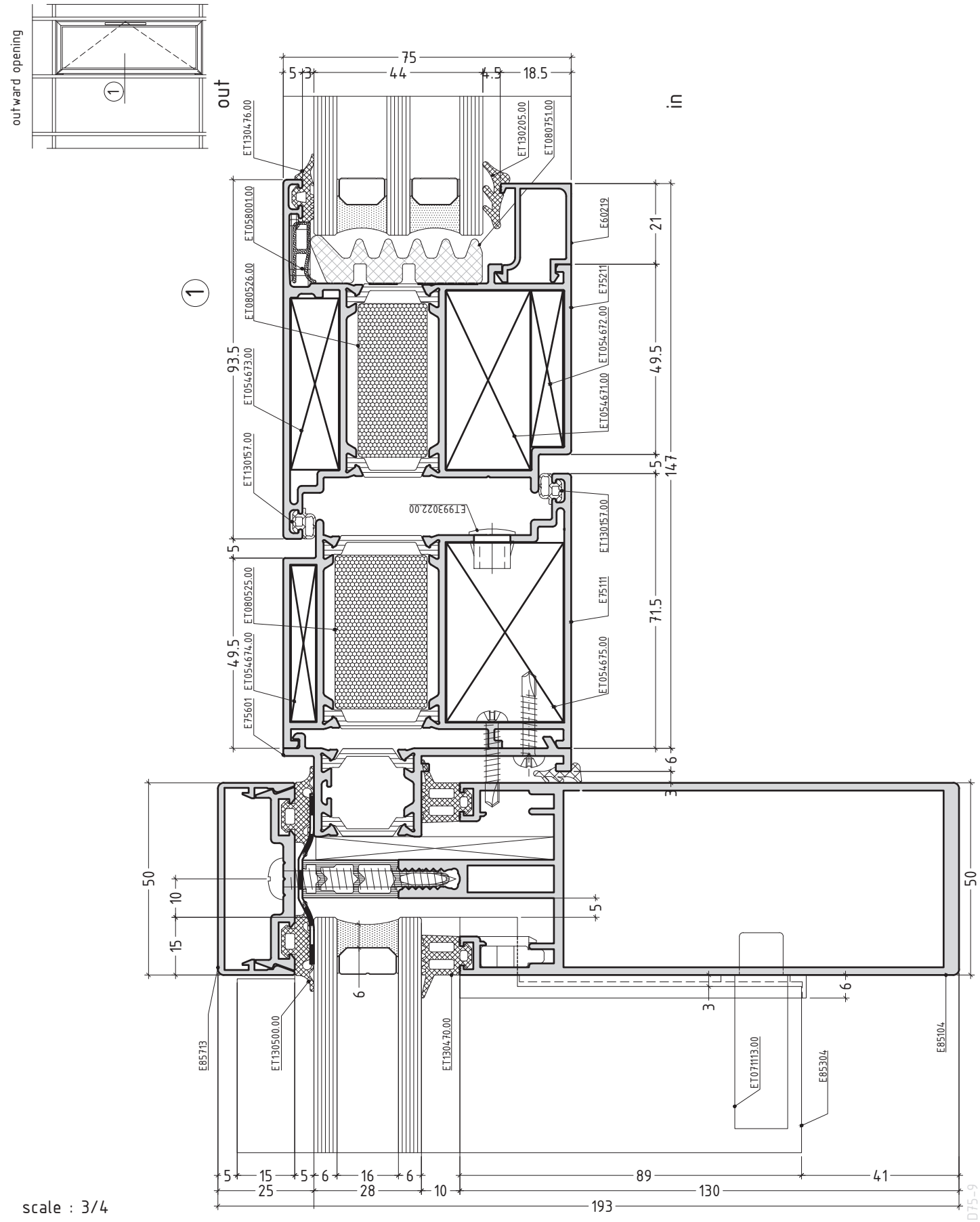

scale : 3/4

flat door system with thermal break

E75FD

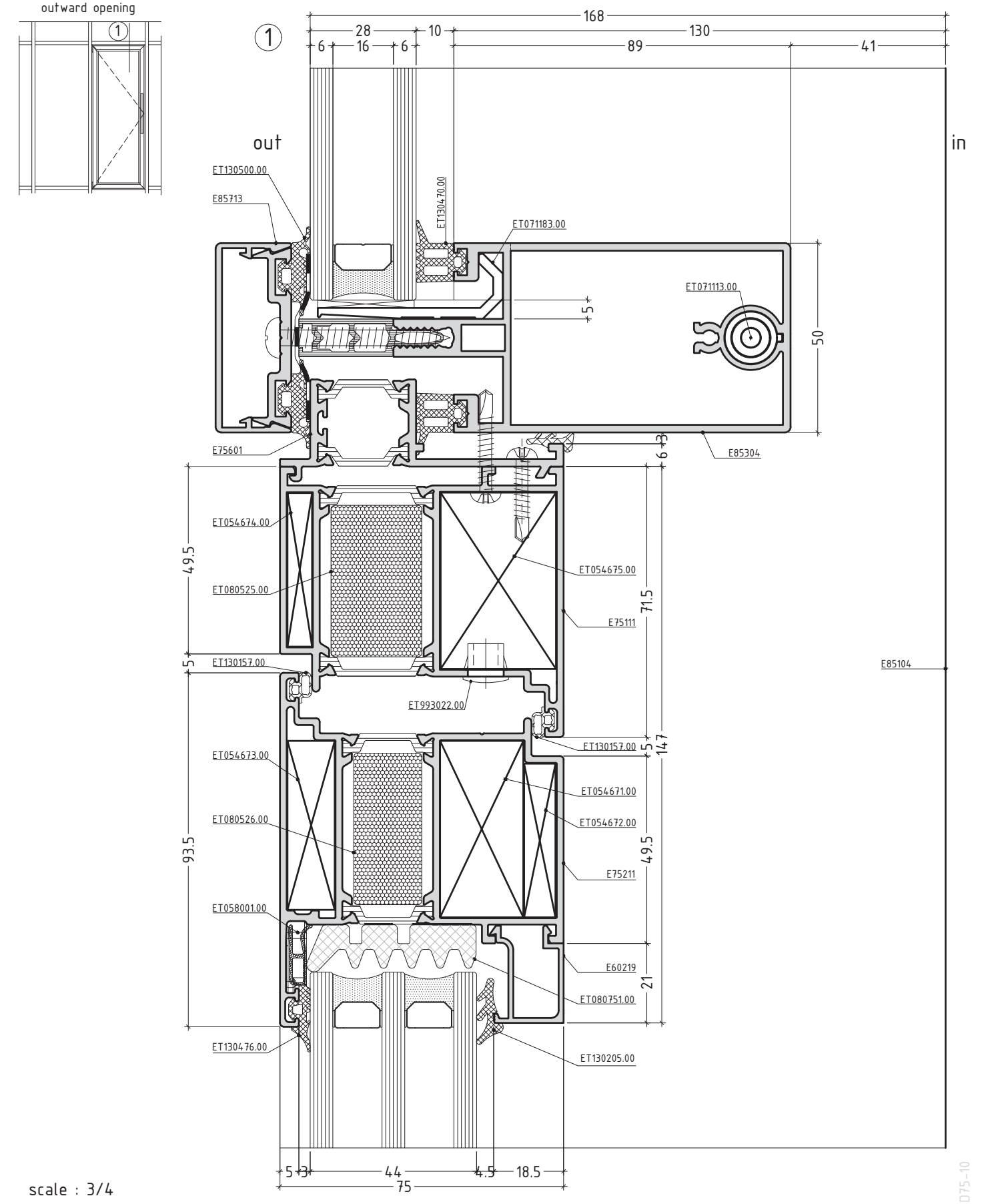

scale : 3/4

flat door system with thermal break

E75FD

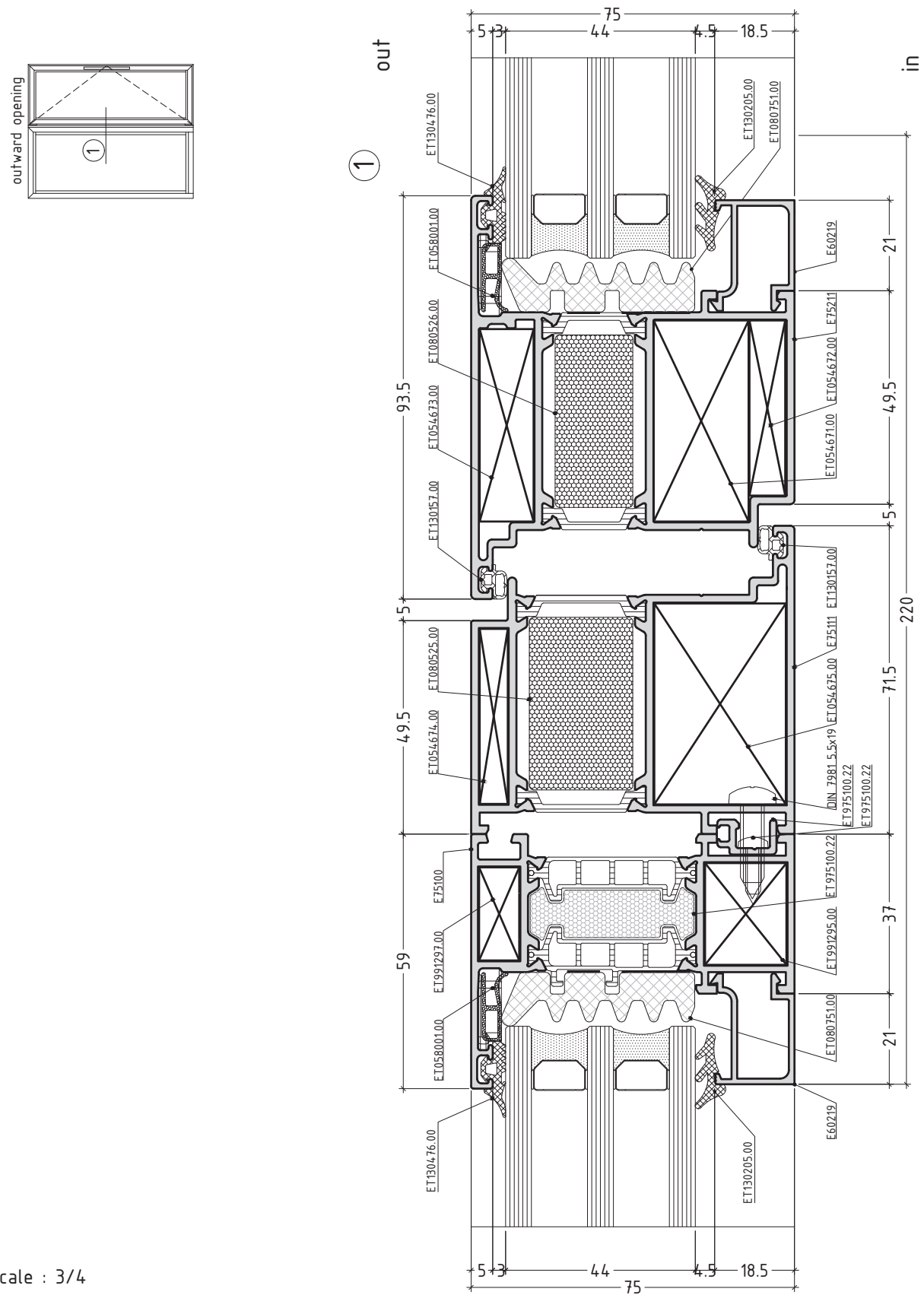

scale : 3/4

D75-11

flat door system with thermal break

E75FD

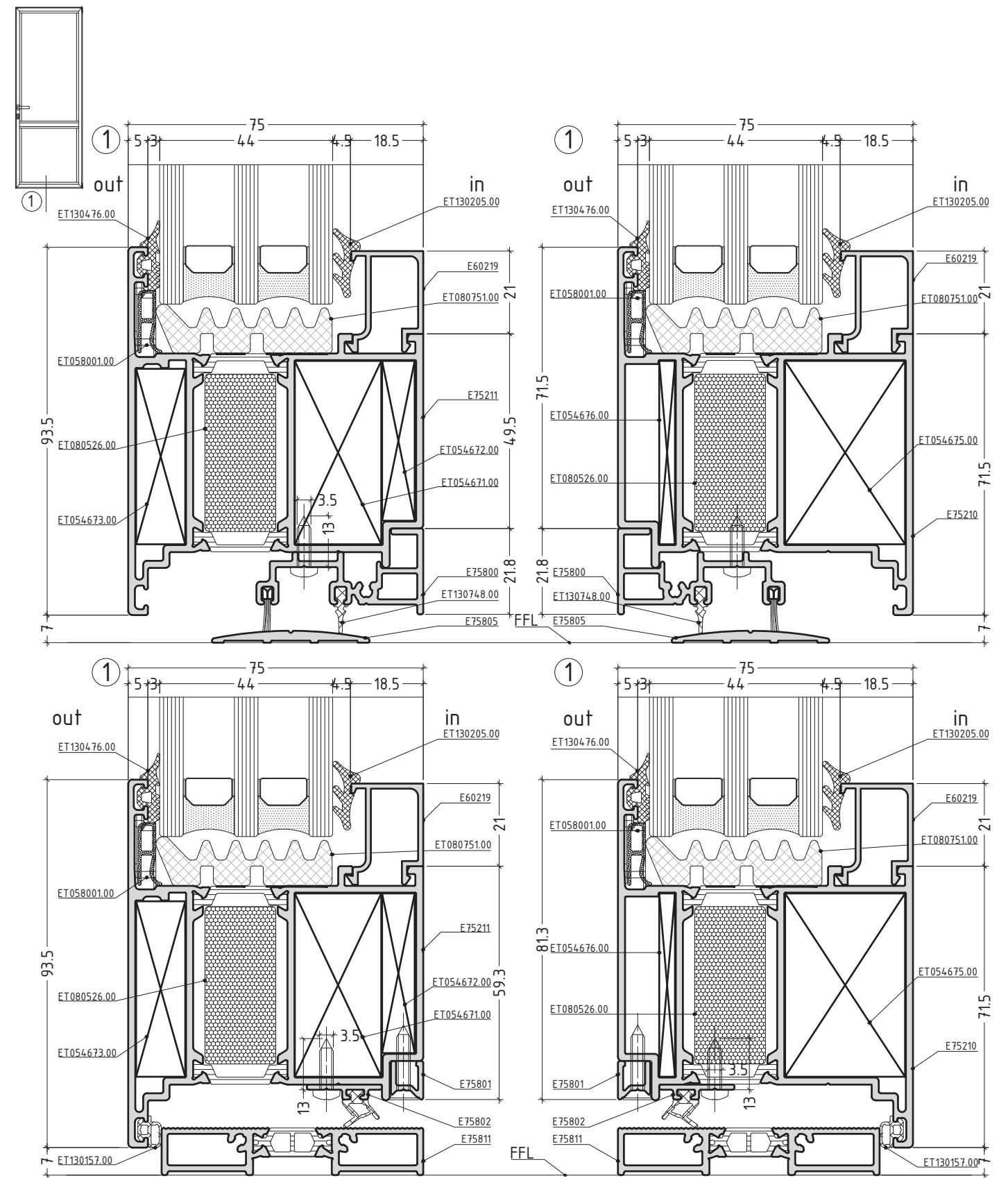

scale : 3/4

D75-12

flat door system with thermal break

E75FD

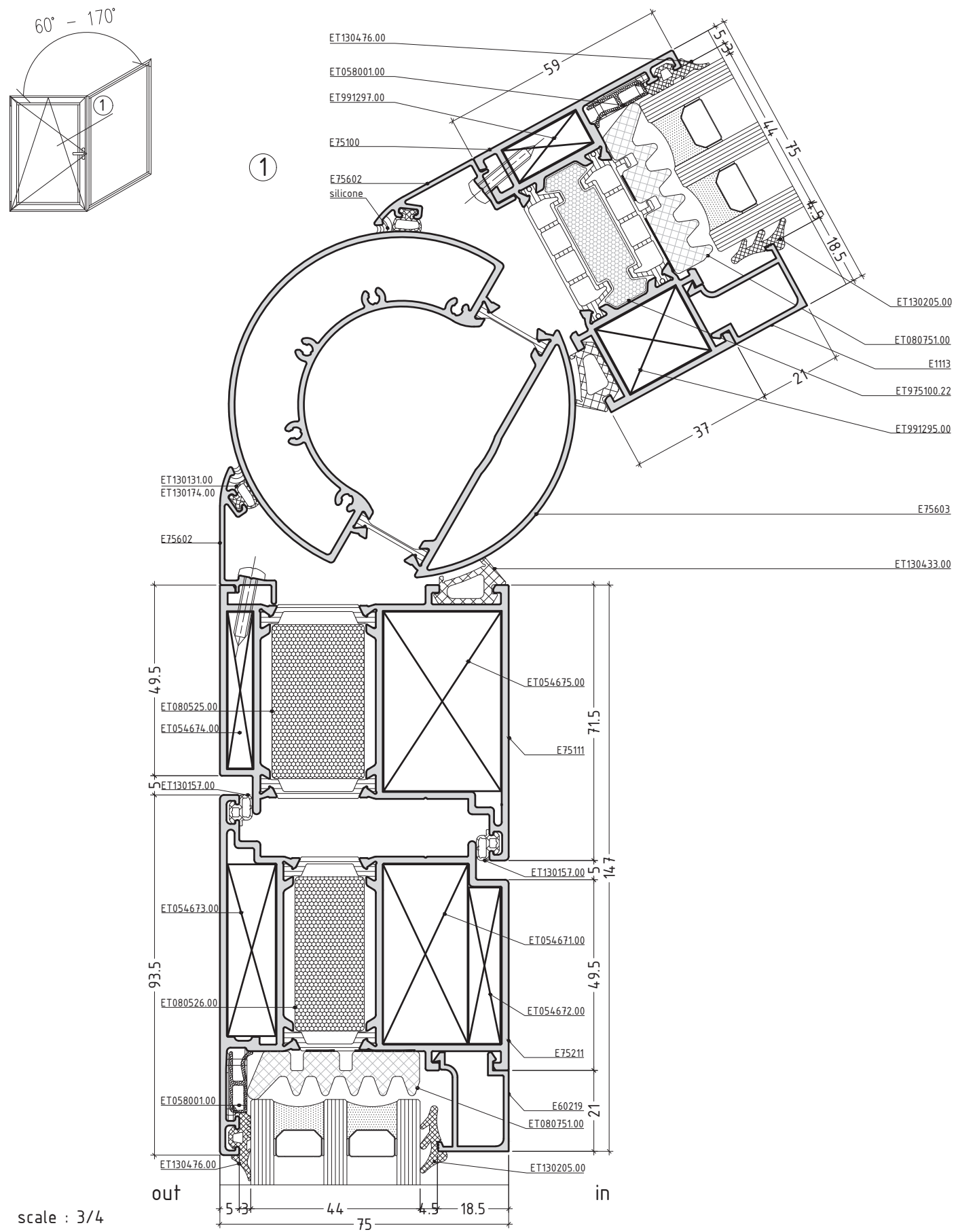

flat door system with thermal break

E75FD

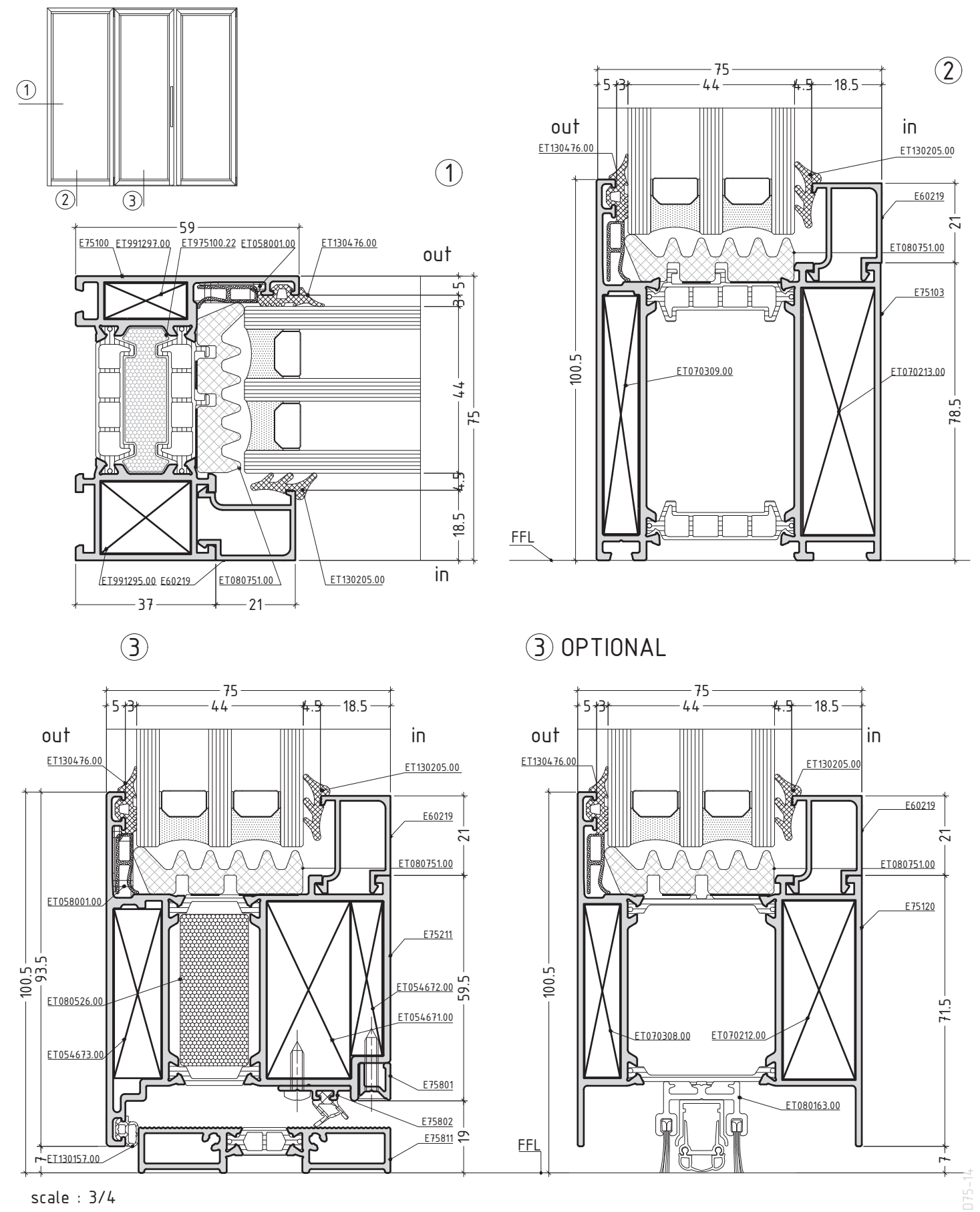

flat door system with thermal break

E75FD

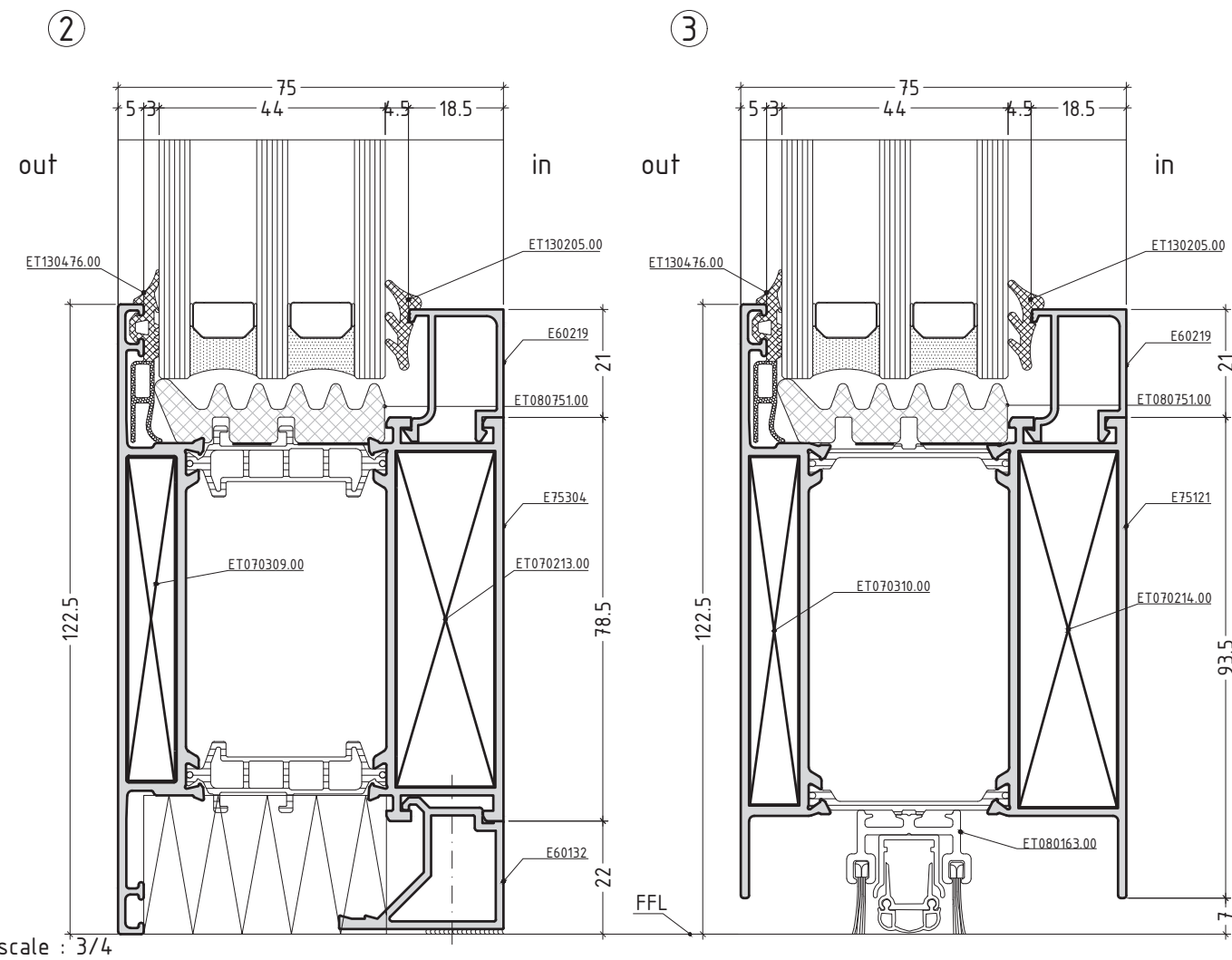
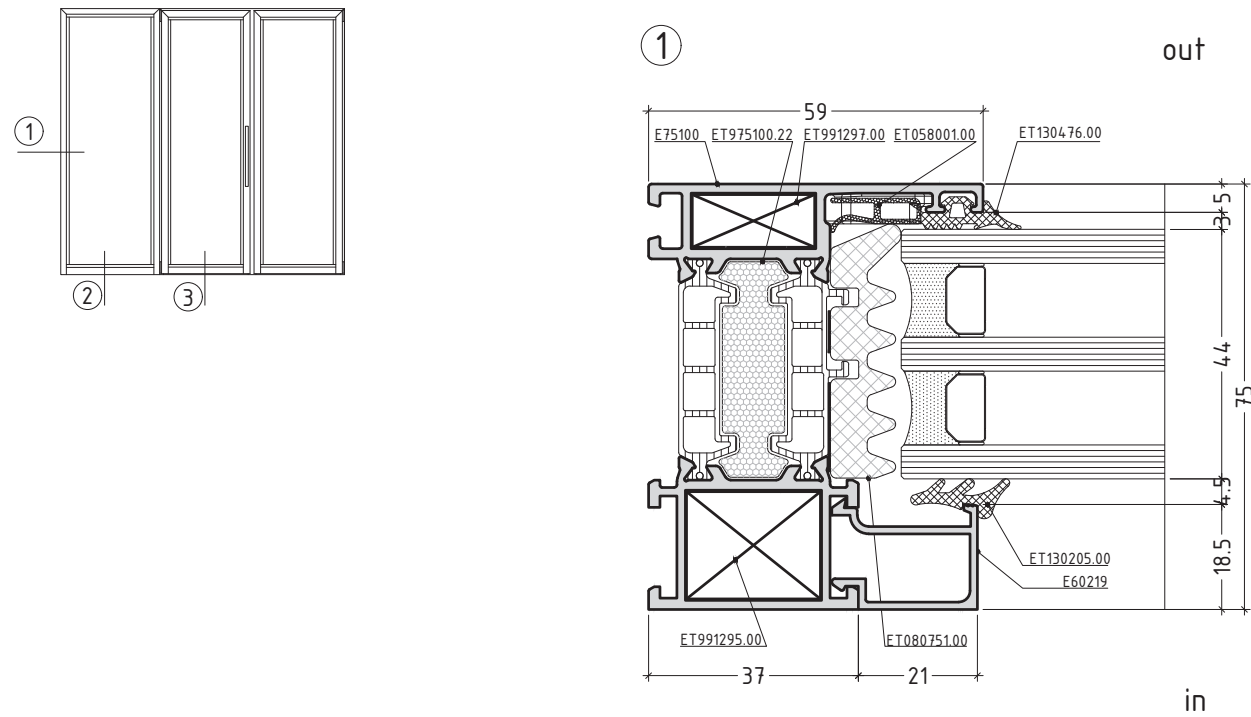

scale : 3/4

D75-15

flat door system with thermal break

E75FD

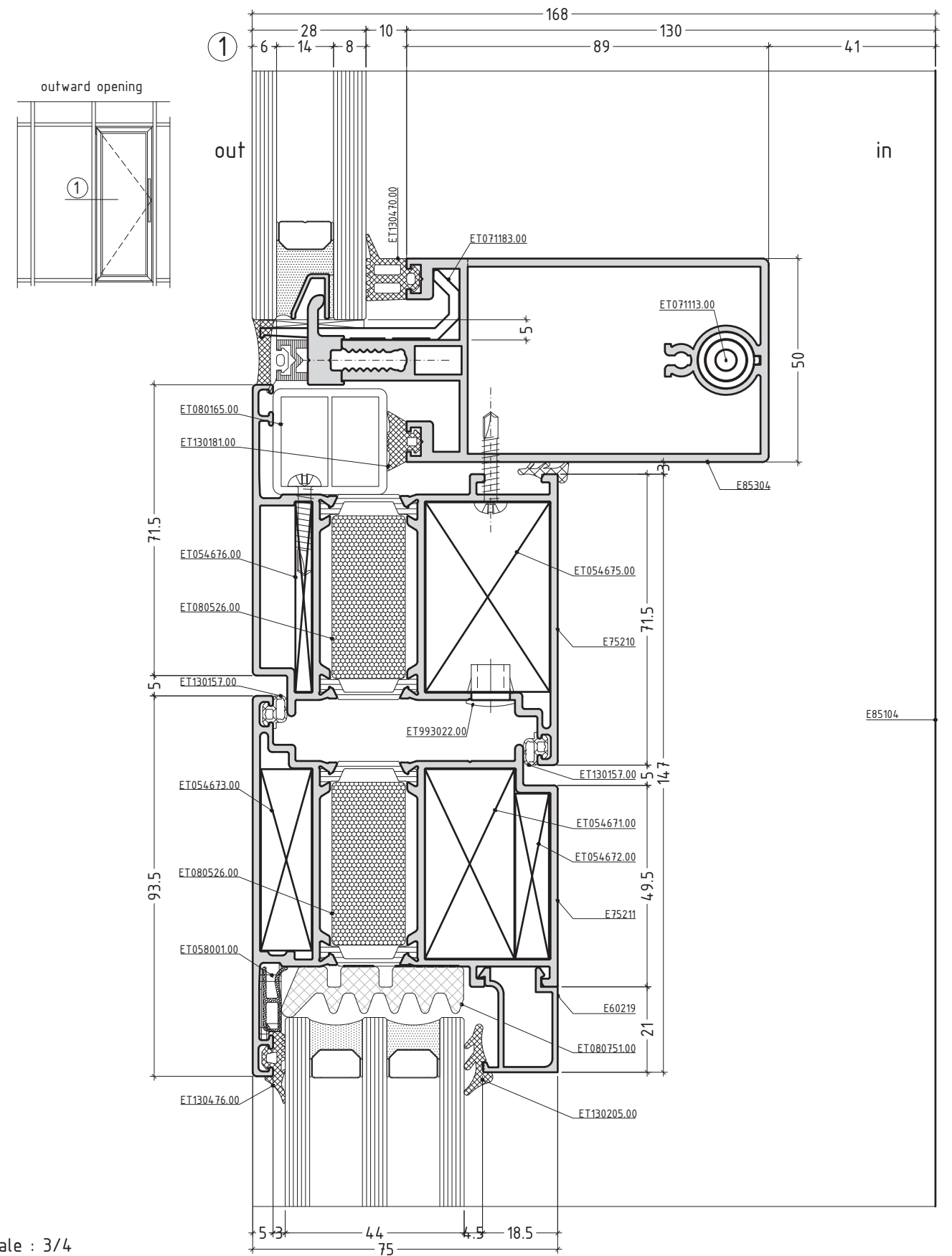

scale : 3/4

D75-16

flat door system with thermal break

E75FD

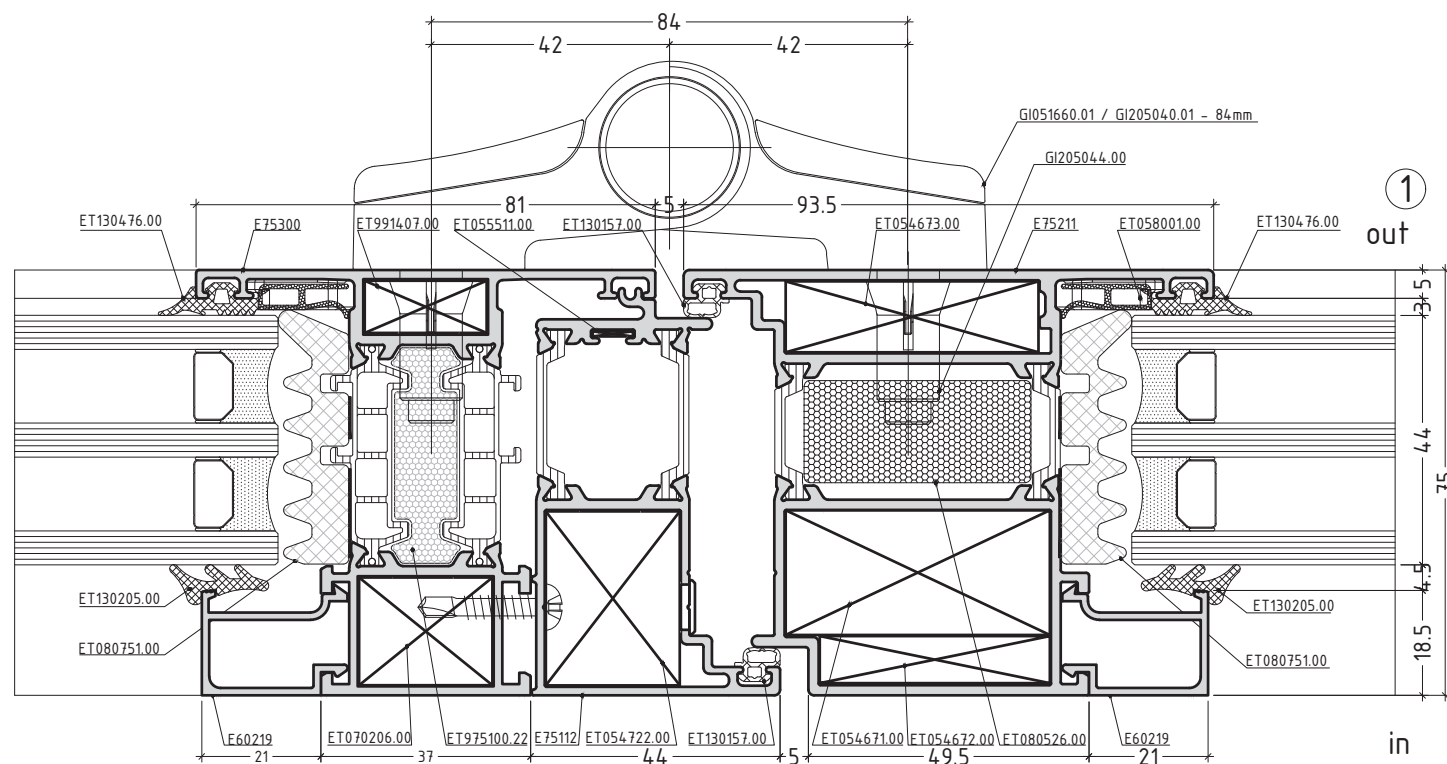
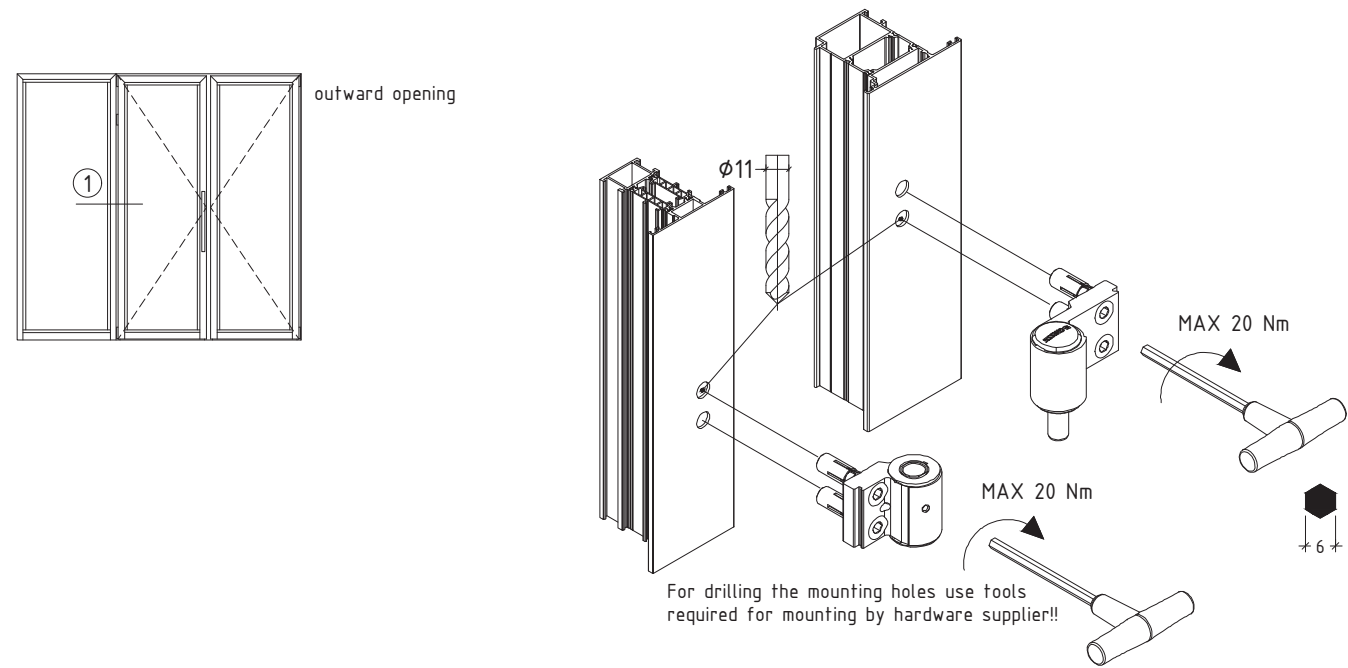

Attention:  
In combination of profile E75300; E75112 and E75211 always use hinges GI051660.01 / GI205040.01 - 84mm with bolt GI205044.00

scale : 3/4

D75-17

flat door system with thermal break

E75FD

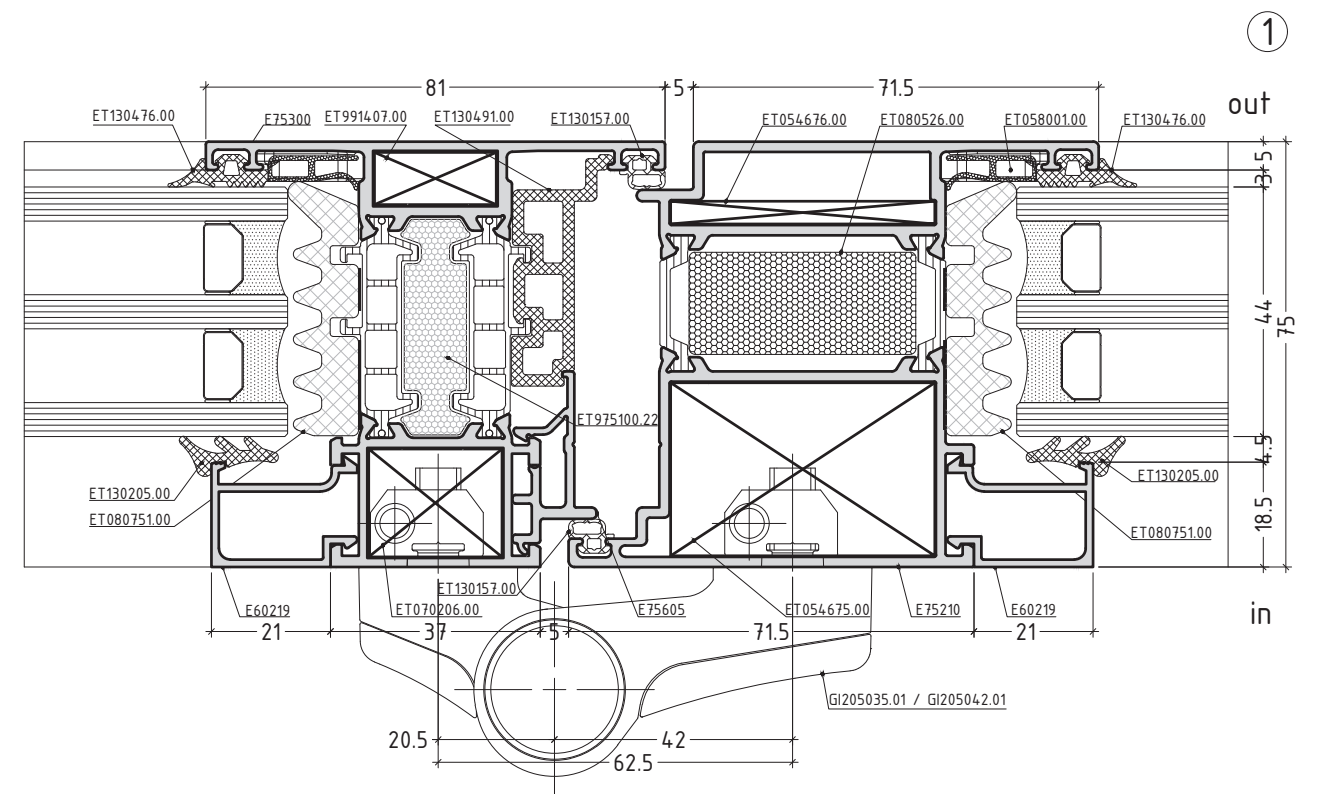
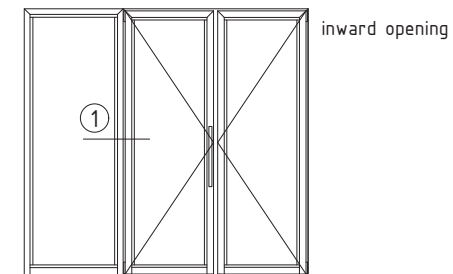

Attention:  
In combination of profile E75300; E75605 and gasket ET130491.00 always use hinges GI205035.01 / GI205042.01

scale : 3/4

D75-18



flat door system with thermal break

E75FD

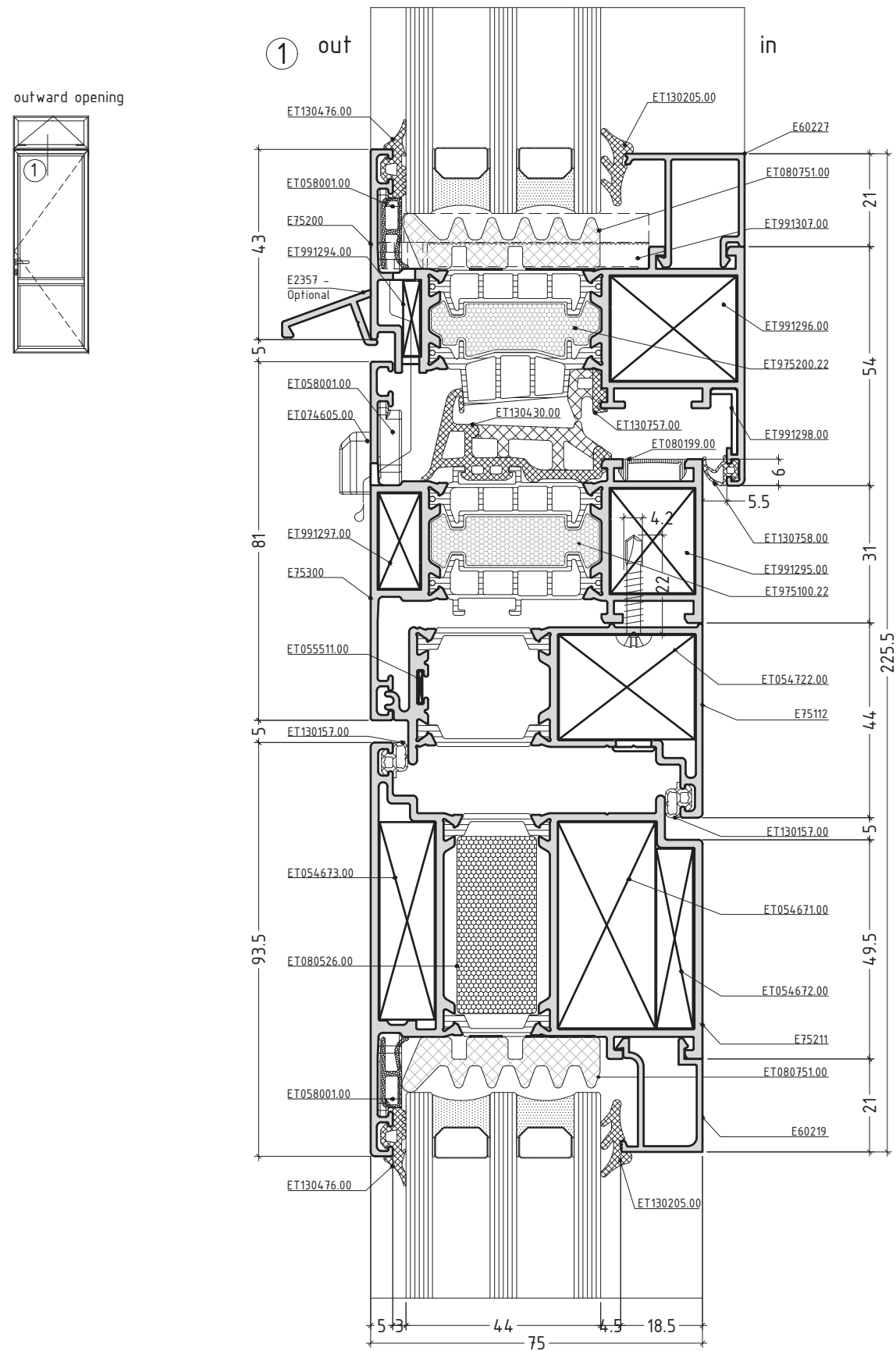

scale : 3/4

D75-19

flat door system with thermal break

E75FD

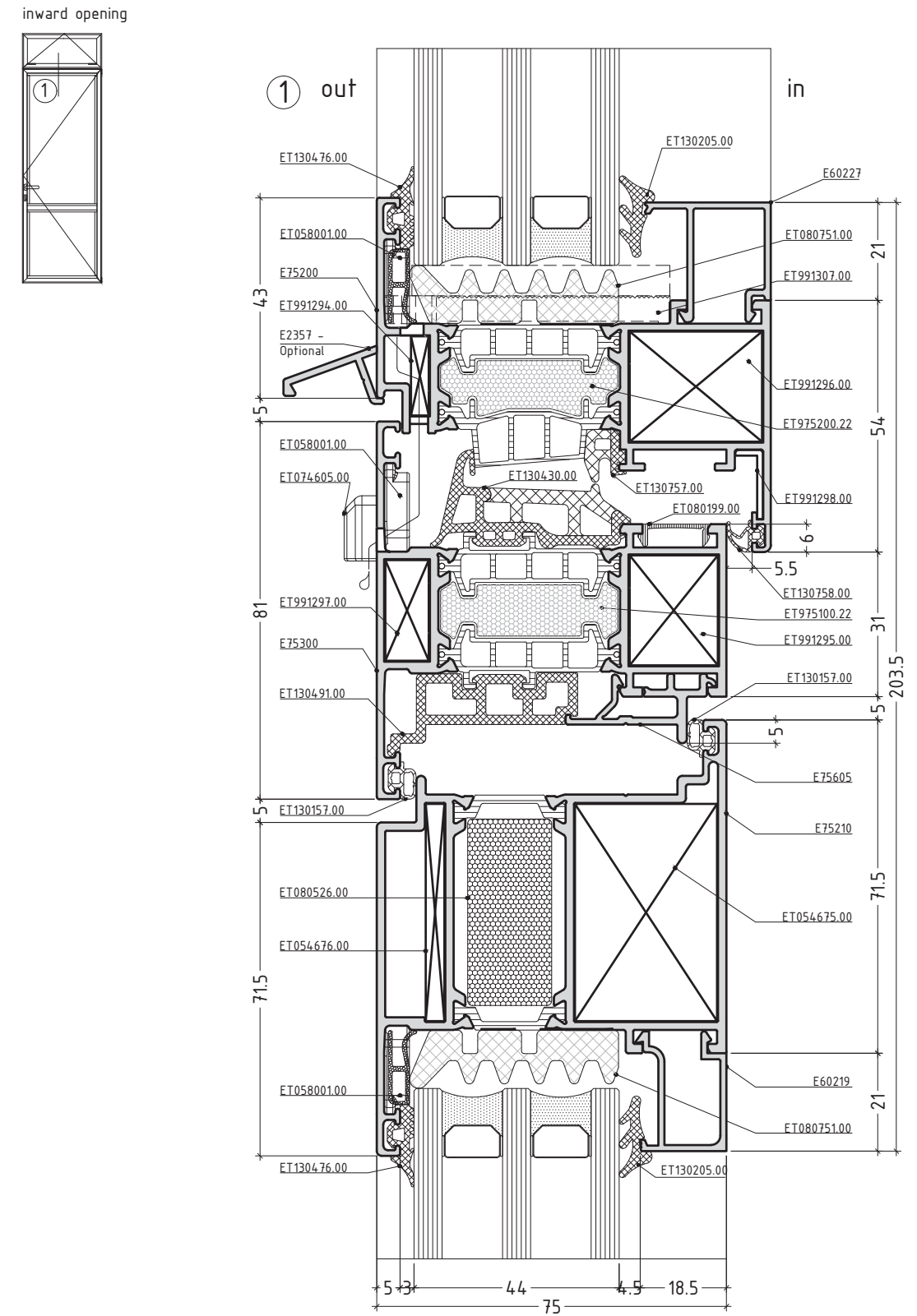

scale : 3/4

D75-20

# GLAZING OPTIONS

external gaskets	GLAZING OPTIONS					GLAZING BEADS	
	INTERNAL GASKETS					security	E602xx
	5 - 6 mm 130176	7 - 8 mm 130177	X mm				
3 mm 130476	5 mm 130205	6 mm 130206	7 mm 130207	8 mm 130208	10 mm 130210		
4 mm 130153							
130476	55	54	53	52	50	E4060807	E60207 old code E504
130153	54	53	52	51	49		
130476	52	51	50	49	47	E4060810	
130153	51	50	49	48	46		
130476	50	49	48	47	45	E4060812	E60212
130153	49	48	47	46	44		
130476	48	47	46	45	43	E4060815	E60215
130153	47	46	45	44	42		
130476	45	44	43	42	40	E4060817	
130153	44	43	42	41	39		
130476	43	42	41	40	38		E60219 old code E530
130153	42	41	40	39	37		
130476	42	41	40	39	37	E4060820	
130153	41	40	39	38	36		
130476	40	39	38	37	35	E4060822	E60222 old code E519
130153	39	38	37	36	34		
130476	37	36	35	34	32	E4060825	E60225 old code E5307
130153	36	35	34	33	31		
130476	35	34	33	32	30	E4060827	E60227
130153	34	33	32	31	29		
130476	32	31	30	29	27	E4060830	E60230
130153	31	30	29	28	26		
130476	30	29	28	27	25	E4060832	
130153	29	28	27	26	24		
130476	27	26	25	24	22	E4060835	E60235
130153	26	25	24	23	21		
130476	25	24	23	22	20	E4060837	E60237
130153	24	23	22	21	19		
130476	22	21	20	19	17	E4060840	
130153	21	20	19	18	16		
130476	20	19	18	17	15	E4060842	E60242 old code E5701
130153	19	18	17	16	14		
130476	17	16	15	14	12	E4060845	
130153	16	15	14	13	11		
130476	15	14	13	12	10		E60247 old code E5700
130153	14	13	12	11	9		

Note:  
Tolerance in dimension chain ±0.5mm

# CUTTING LISTS & MACHININGS



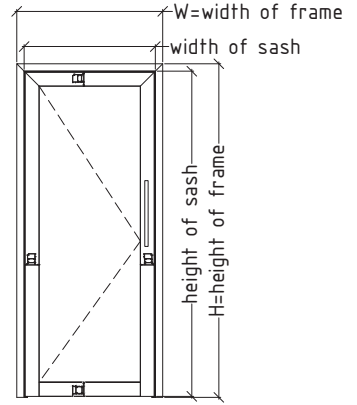
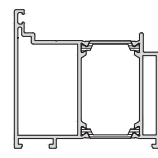
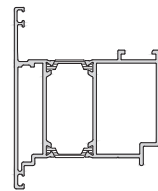
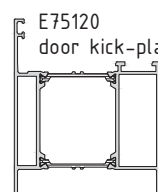
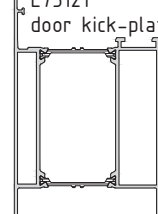



outward opening - single sash door

profile selection		calculation of cutting length for one sash door		
		pieces	cutting formula	cutting angles
				
<b>E75111</b> frame-outward 		width of frame	1	W 2x45°
		height of frame-left	1	H 1x45° + 1x90° up down
		height of frame-right	1	H 1x45° + 1x90° up down
<b>E75211</b> sash-outward 		width of sash-outward	1	W - 109 2x45°
		height of sash-outward left	1	H - 61.5 1x45° + 1x90° up down
		height of sash-outward right	1	H - 61.5 1x45° + 1x90° up down
option 1				
<b>E75120</b> door kick-plate 		width of door kick-plate	1	width of sash-134,5 2x90°
option 2				
<b>E75121</b> door kick-plate 		width of door kick-plate	1	width of sash-134,5 2x90°

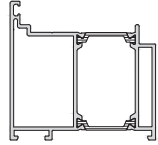
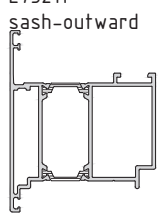
not to scale

M75D-1

outward opening - single sash door

profile selection		calculation of cutting length for one sash door		
profile selection		pieces	cutting formula	cutting angles
 E75111 frame-outward	width of frame	1	W	2x45°
	height of frame-left	1	H	1x45° + 1x90° up down
	height of frame-right	1	H	1x45° + 1x90° up down
 E75211 sash-outward	width of sash-outward	2	W - 109	2x45°
	height of sash-outward	2	H - 61.5	2x45°
option 1				
 E75810 or E75811	width of door threshold	1	W - 143	2x90°
 E75802 bottom rail	width of bottom rail	1	width of sash-32	2x90°
 E75801	width of addition	1	width of sash-47	2x90°
option 2				
 E75800 bottom rail - optional finish	width of bottom rail	1	width of sash-48	2x90°
 E75805 - optional finish	width of door threshold	1	W - 125	2x90°

not to scale

M75D-2

outward opening - single sash door

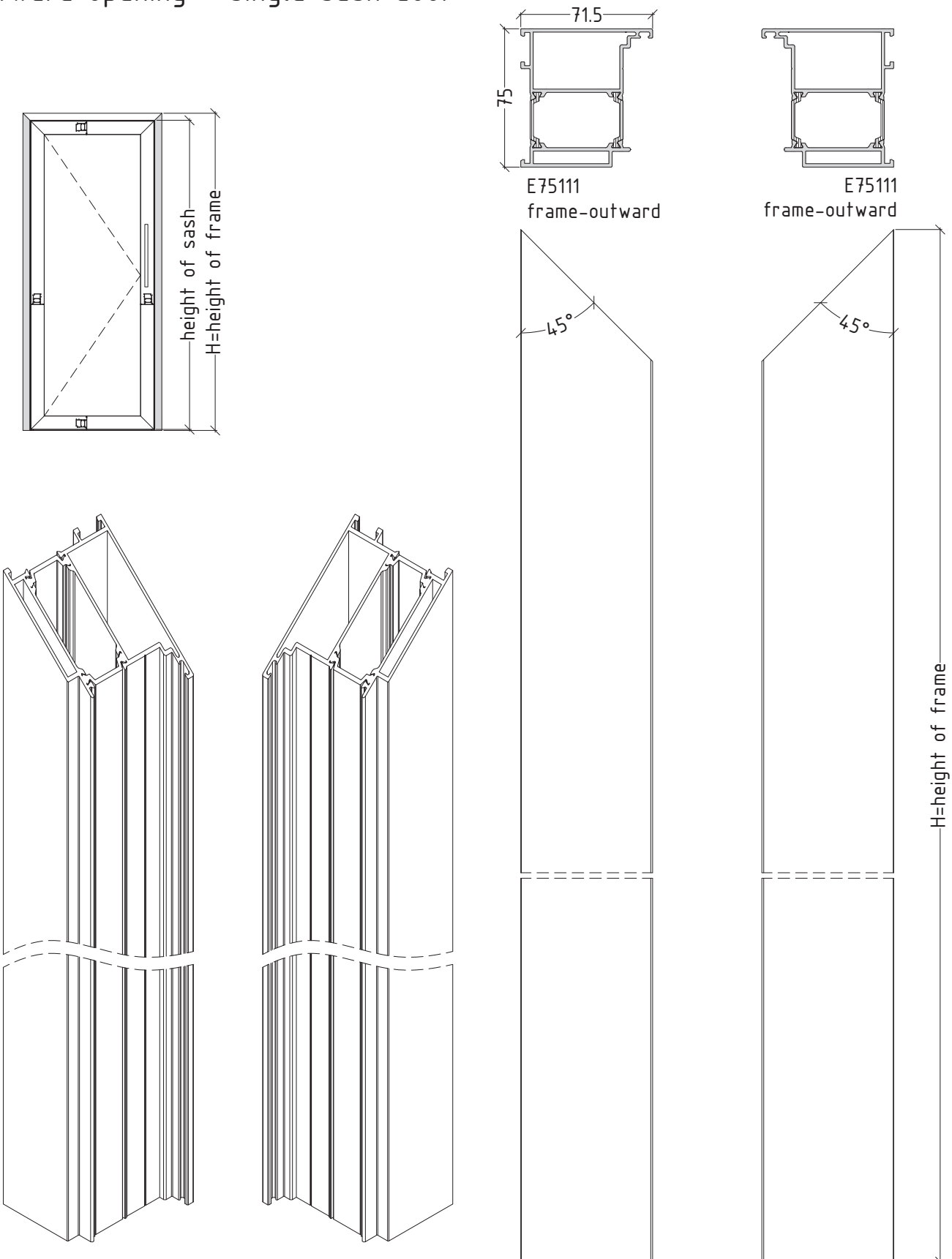

not to scale

M75D-3

outward opening - single sash door

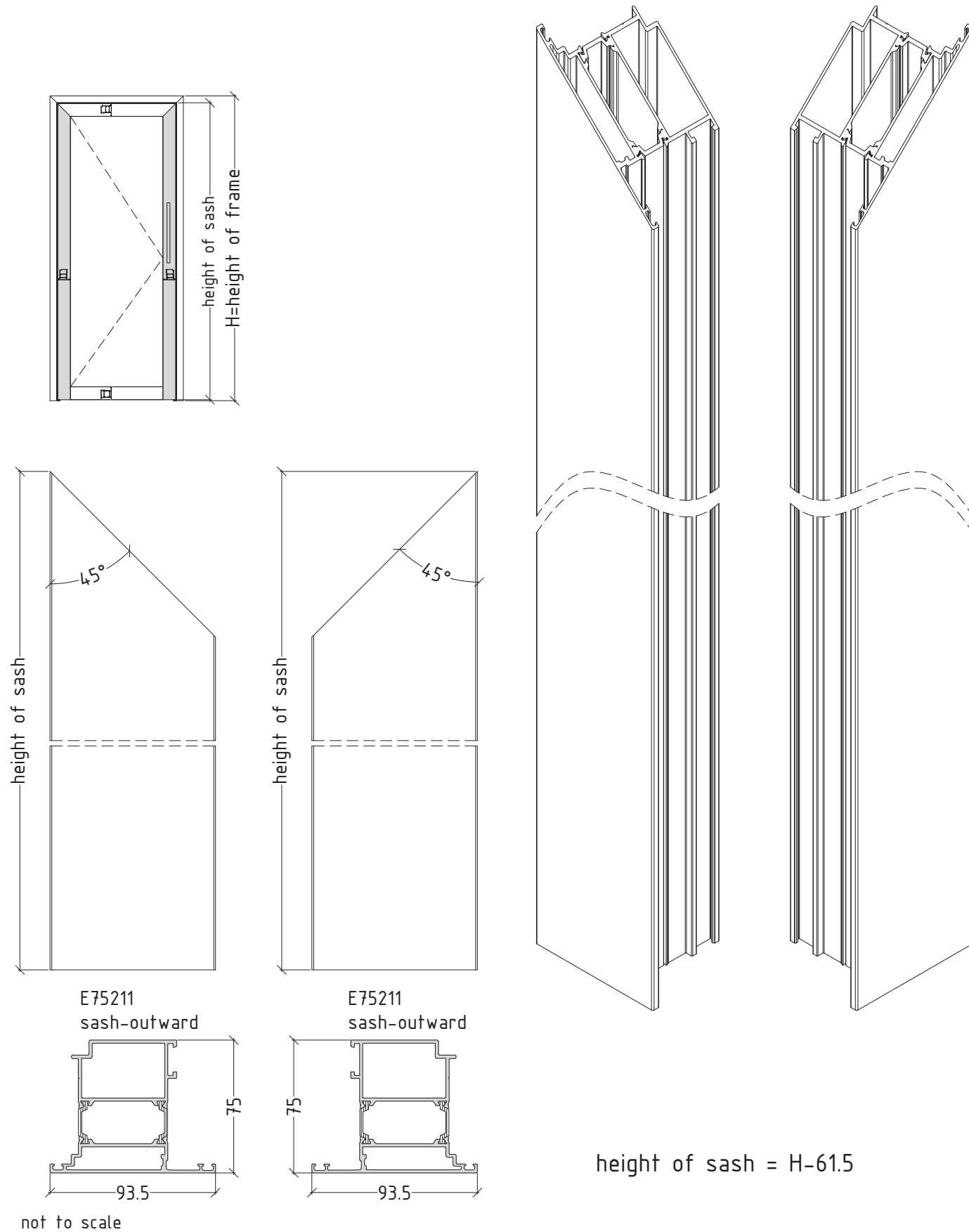

not to scale

outward / inward opening - single sash door

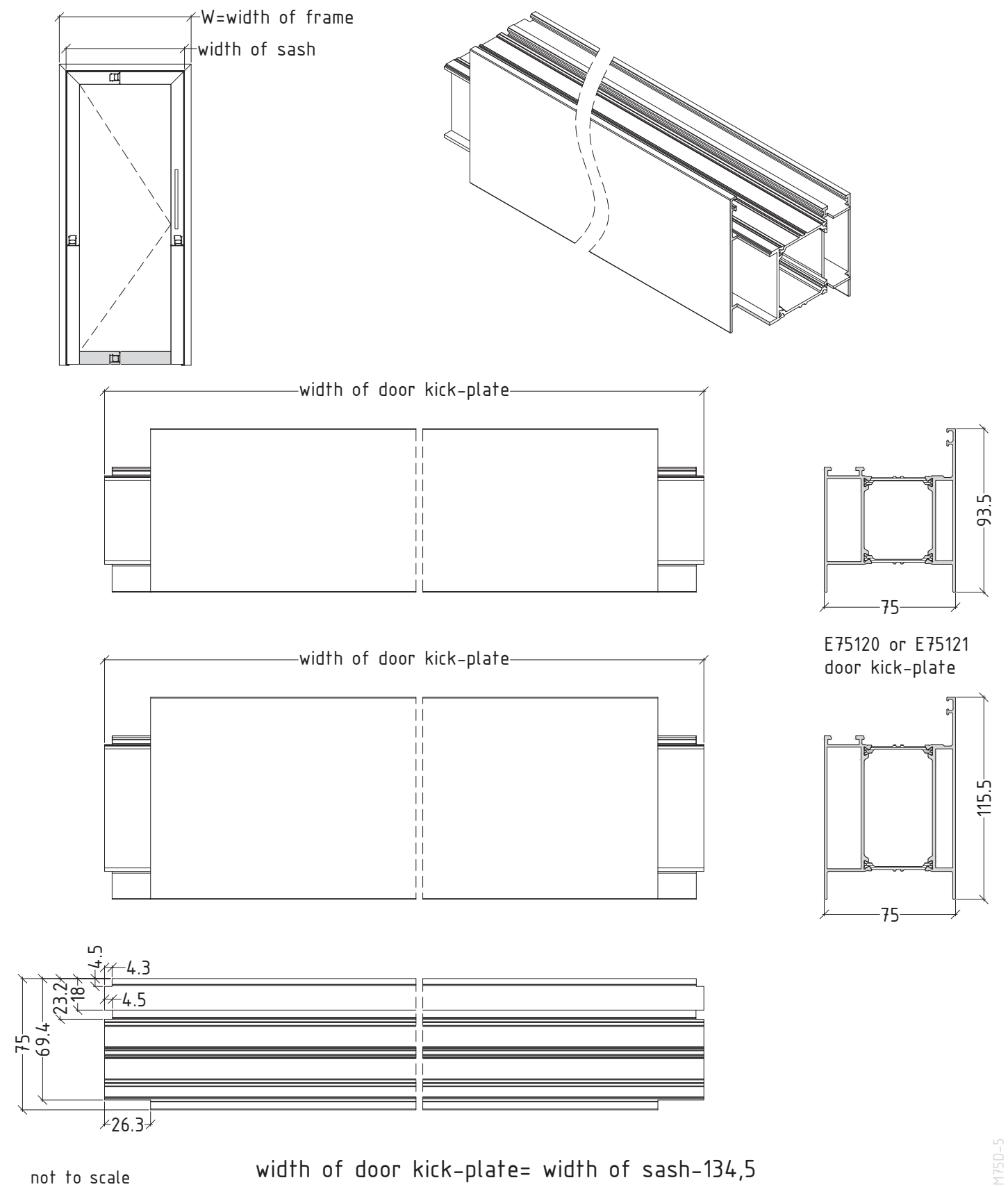

not to scale

flat door system with thermal break

E75FD

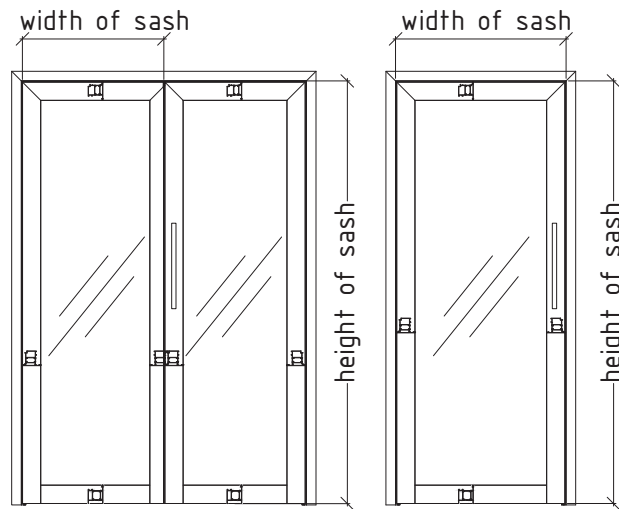

	sash profile selection	calculation of cutting length for glass unit	
		 E75211 sash-outward cutting formula	 E75210 sash-inward cutting formula
 bottom rail profile selection	 E75120 door kick-plate	width of glass	width of sash-157
		height of glass	height of sash-157
	 E75121 door kick-plate	width of glass	width of sash-157
		height of glass	height of sash-179

not to scale

M75D-6

flat door system with thermal break

E75FD

	sash profile selection	calculation of cutting length for glass unit	
		 E75211 sash-outward cutting formula	 E75210 sash-inward cutting formula
 dimension of glass unit		width of glass	width of sash-157
		height of glass	height of sash-157

not to scale

M75D-7





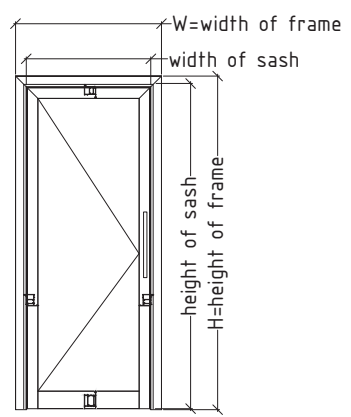
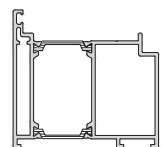
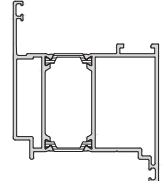
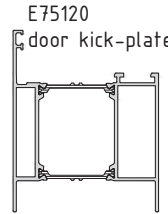
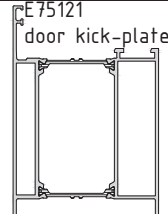



inward opening - single sash door

		calculation of cutting length for one sash door		
profile selection		pieces	cutting formula	cutting angles
E75110 frame-inward 	width of frame	1	W	2x45°
	height of frame-left	1	H	1x45° + 1x90° up down
	height of frame-right	1	H	1x45° + 1x90° up down
E75210 sash-inward 	width of sash-inward	1	W - 109	2x45°
	height of sash-inward left	1	H - 61.5	1x45° + 1x90° up down
	height of sash-inward right	1	H - 61.5	1x45° + 1x90° up down
option 1				
E75120 door kick-plate 	width of door kick-plate	1	width of sash-134,5	2x90°
option 2				
E75121 door kick-plate 	width of door kick-plate	1	width of sash-134,5	2x90°

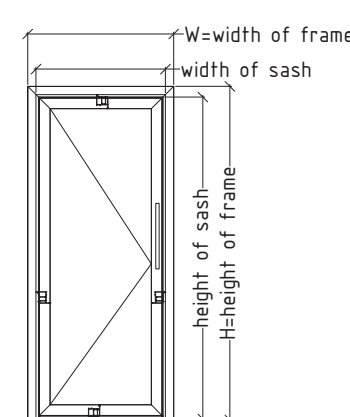
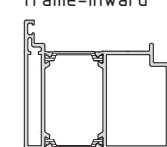
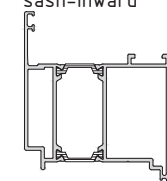
not to scale

M75D-8

inward opening - single sash door

		calculation of cutting length for one sash door		
profile selection		pieces	cutting formula	cutting angles
E75110 frame-inward 	width of frame	1	W	2x45°
	height of frame-left	1	H	1x45° + 1x90° up down
	height of frame-right	1	H	1x45° + 1x90° up down
E75210 sash-inward 	width of sash-inward	2	W - 109	2x45°
	height of sash-inward	2	H - 61.5	2x45°
option 1				
E75810 or E75811 	width of door threshold	1	W - 143	2x90°
E75802 bottom rail 	width of bottom rail	1	width of sash-32	2x90°
E75801 	width of addition	1	width of sash-47	2x90°
option 2				
E75800 bottom rail - optional finish 	width of bottom rail	1	width of sash-48	2x90°
E75805 - optional finish 	width of door threshold	1	W - 125	2x90°

not to scale

M75D-9

inward opening - single sash door

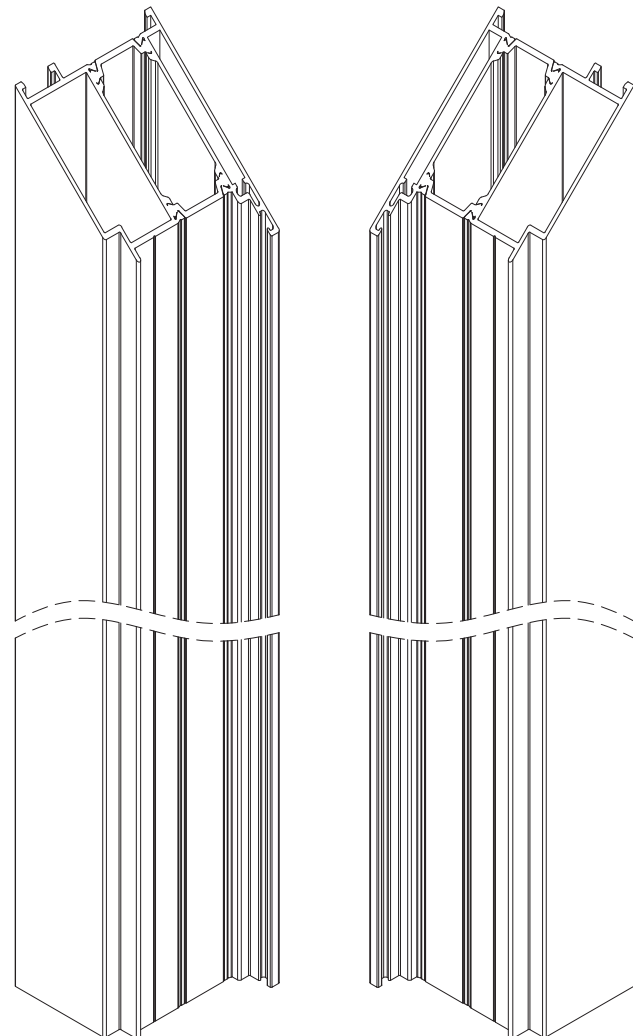
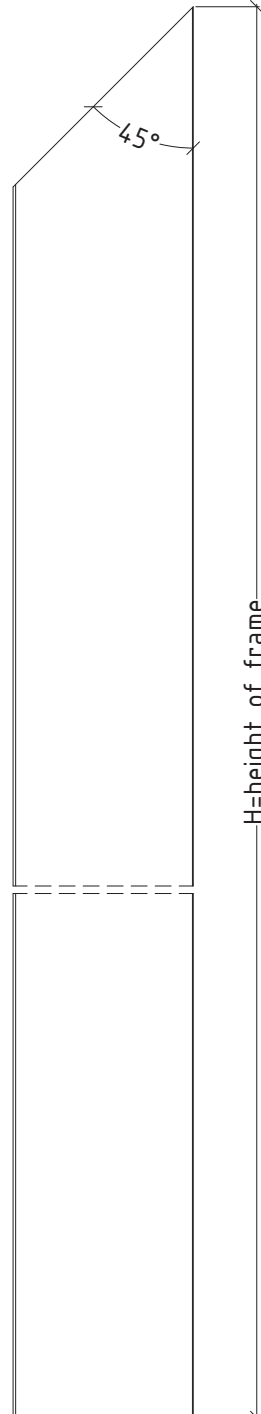
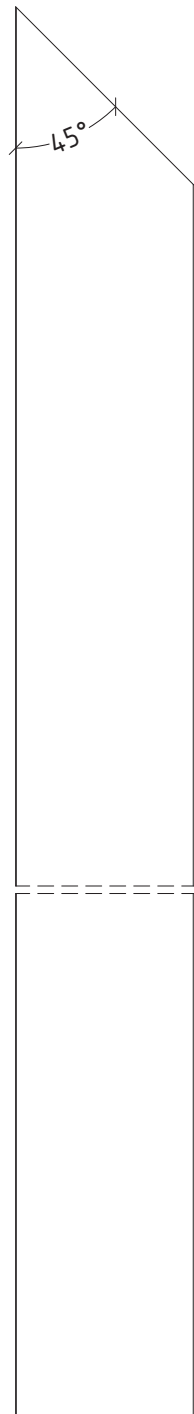
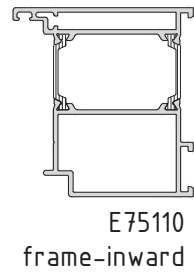
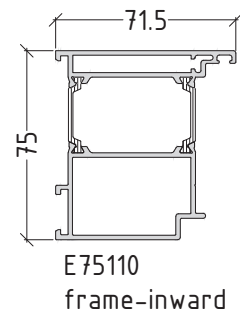
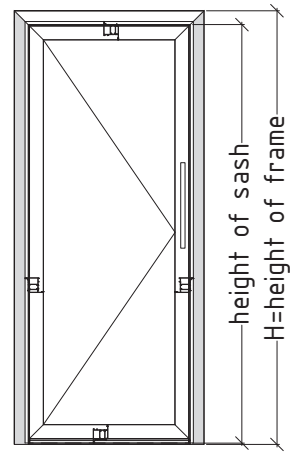

not to scale

M75D-10

inward opening - single sash door

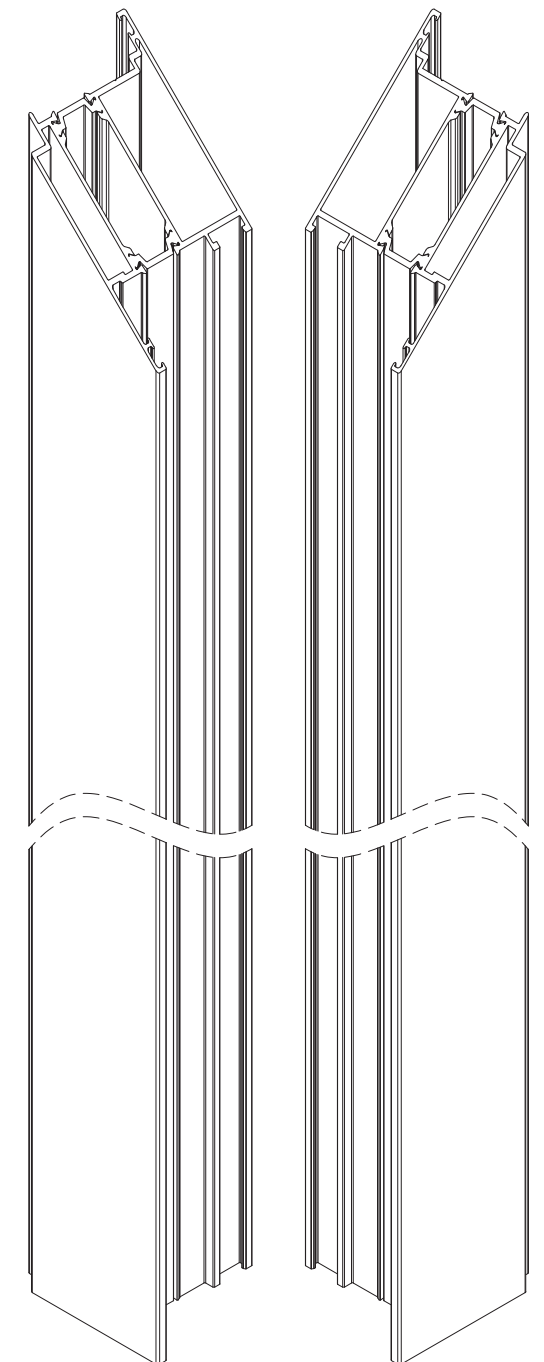
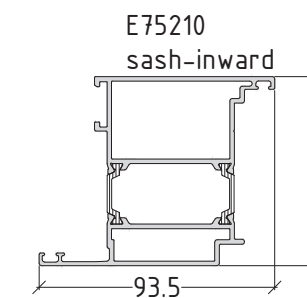
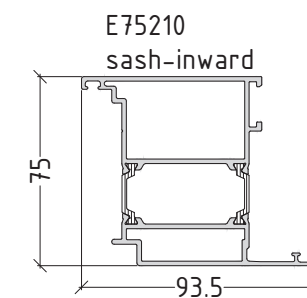
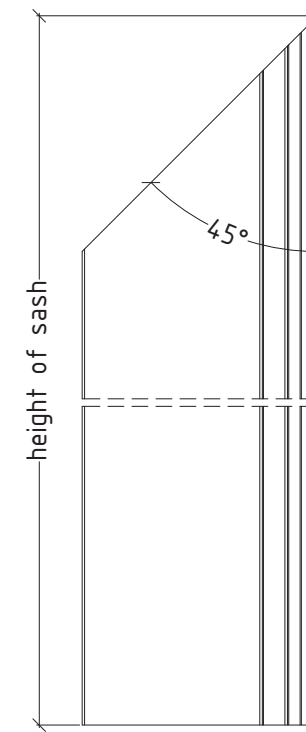
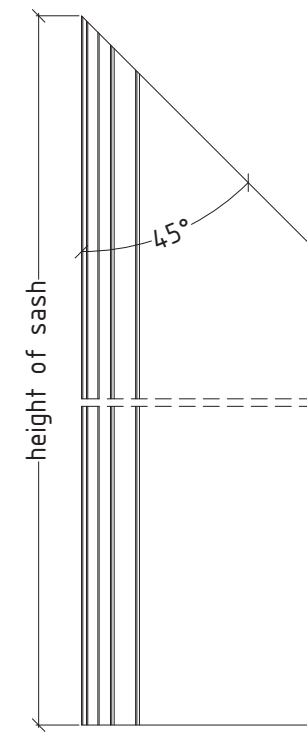
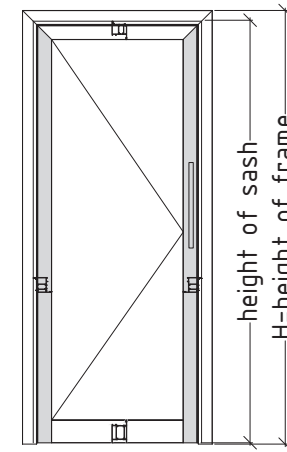

height of sash = H-61.5

not to scale

M75D-11

outward opening - double sash door

		calculation of cutting length for two sash door		
profile selection		pieces	cutting formula	cutting angles
E75111 frame-outward 	width of frame	1	W	2x45°
	height of frame-left	1	H	1x45° + 1x90° up down
	height of frame-right	1	H	1x45° + 1x90° up down
E75211 sash-outward 	width of sash-outward	2	$\frac{W - 94}{2}$	2x45°
	height of sash-outward	2 +	H - 61.5	1x45° + 1x90° up down
E75210 sash-inward 	height of sash-inward	1	H - 61.5	1x45° + 1x90° up down
option 1				
E75120 door kick-plate 	width of door kick-plate	2	width of sash-134,5	2x90°
option 2				
E75121 door kick-plate 	width of door kick-plate	2	width of sash-134,5	2x90°

not to scale

M75D-12

outward opening - double sash door



		calculation of cutting length for two sash door		
profile selection		pieces	cutting formula	cutting angles
E75111 frame-outward 	width of frame	1	W	2x45°
	height of frame-left	1	H	1x45° + 1x90° up down
	height of frame-right	1	H	1x45° + 1x90° up down
E75211 sash-outward 	width of sash-outward	4	$\frac{W - 94}{2}$	2x45°
	height of sash-outward	2 +	H - 61.5	2x45°
E75210 sash-inward 	height of sash-inward	1	H - 61.5	2x45°
option 1				
E75810 or E75811 	width of door threshold	1	W - 143	2x90°
E75802 bottom rail 	width of bottom rail	2	width of sash-32	2x90°
E75801 	width of addition	1	width of sash-47 for active sash	2x90°
	width of addition	1	width of sash-25 for passive sash	2x90°

not to scale

M75D-13

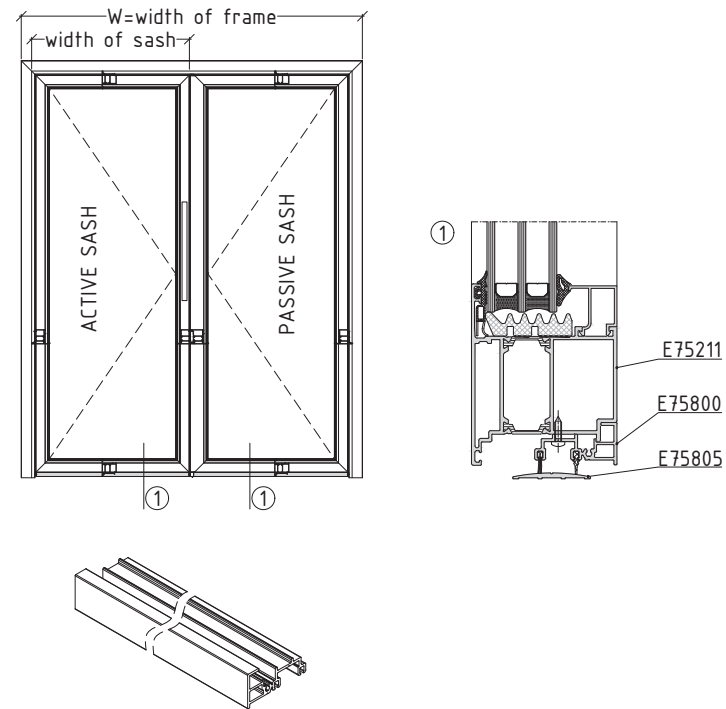
outward opening - double sash door

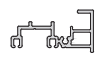

profile selection		calculation of cutting length for two sash door		
profile selection		pieces	cutting formula	cutting angles
option 2				
E75800 bottom rail 	width of bottom rail	1	width of sash-48 for active sash	2x90°
	width of bottom rail	1	width of sash-42 for passive sash	2x90°
E75805 	width of door threshold	1	W - 125	2x90°

not to scale

M75D-14

outward opening - double sash door

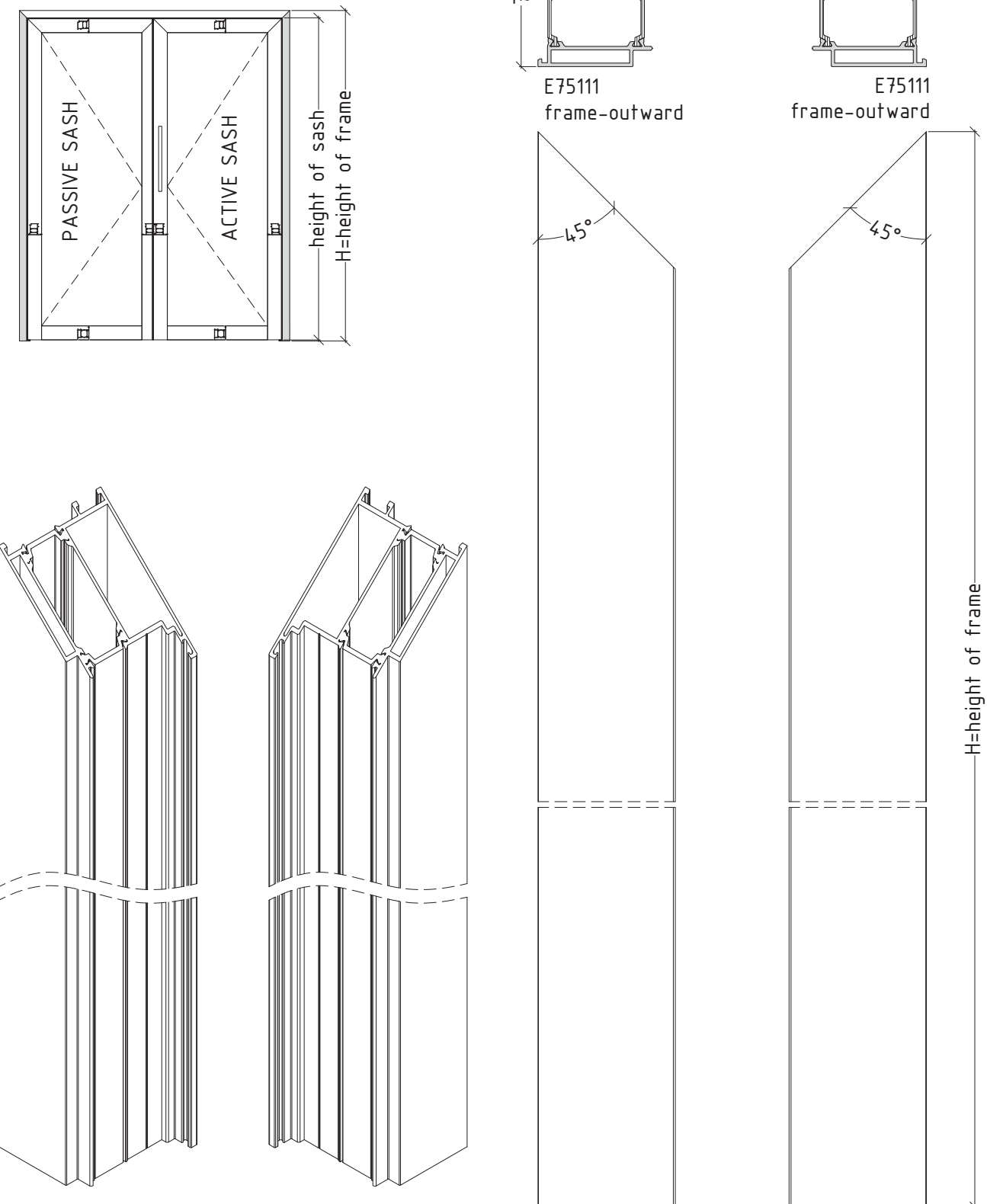

not to scale

M75D-15

flat door system with thermal break

E75FD

outward opening - double sash door

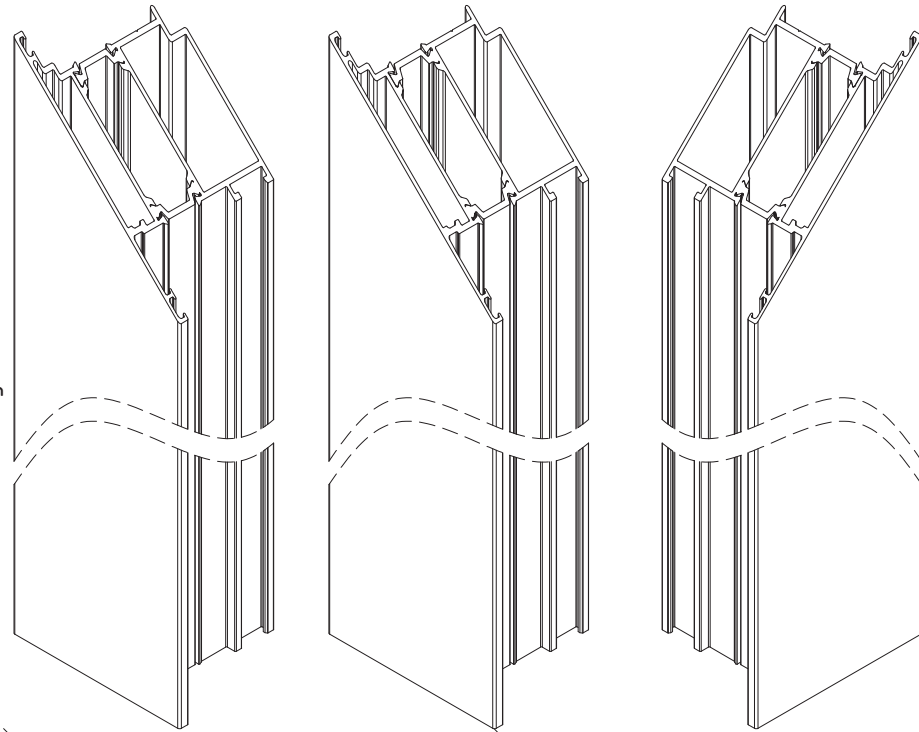
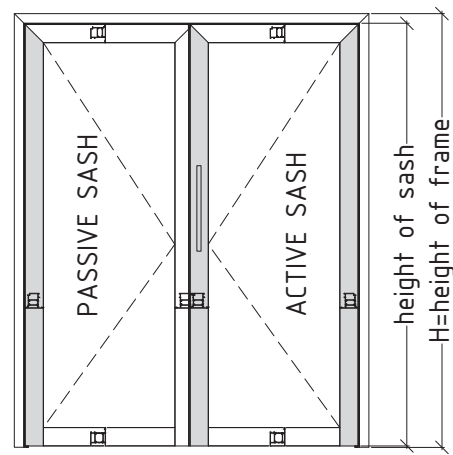

height of sash = H - 61.5

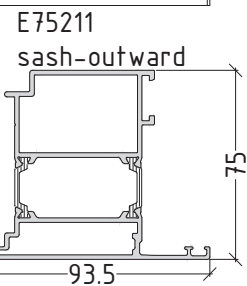
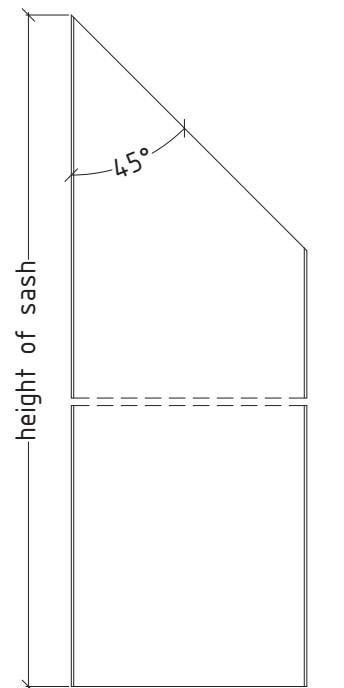

not to scale

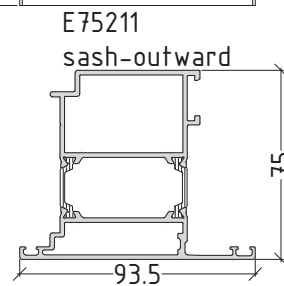
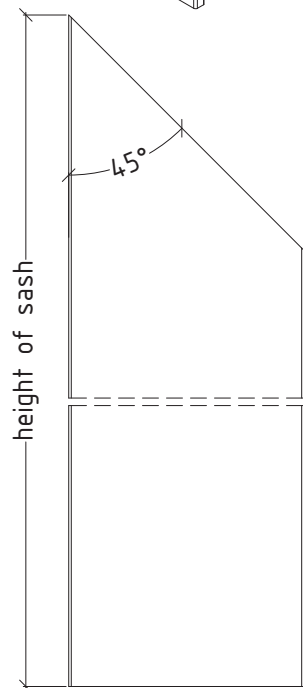

height of sash = H-61.5

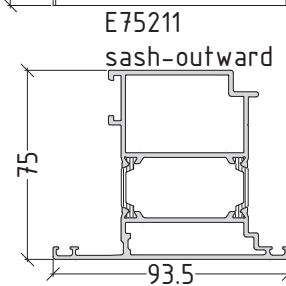
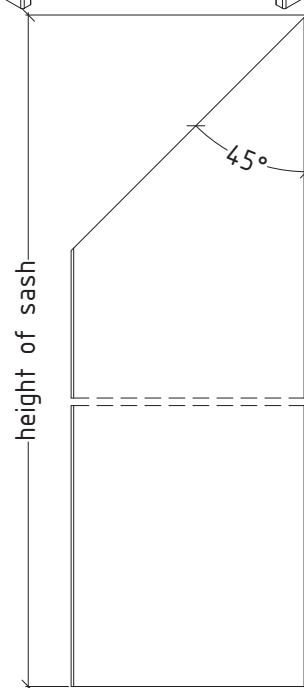

M75D-16

flat door system with thermal break

E75FD

outward opening - double sash door

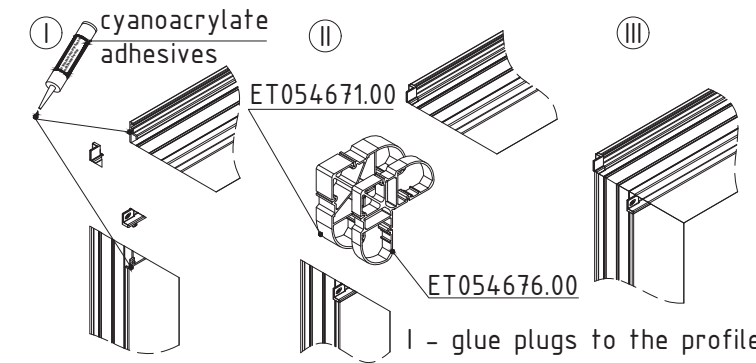
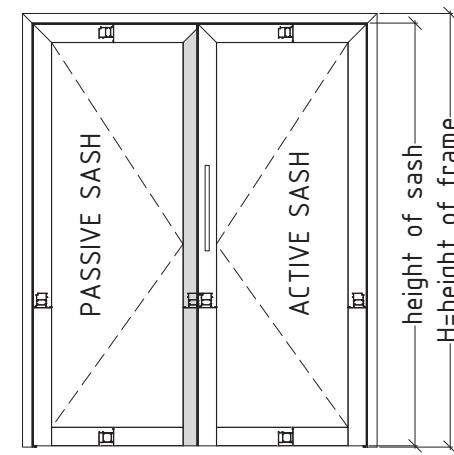

Sequence of assembly between sash-inward and sash-outward and specific joint corners usage

- I - glue plugs to the profile
- II - insert corner brackets in combination ET054671.00 + ET054676.00 for sash E75210 sash-inward + E75211 sash-outward
- III - crimp profiles

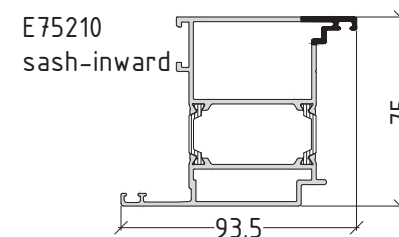
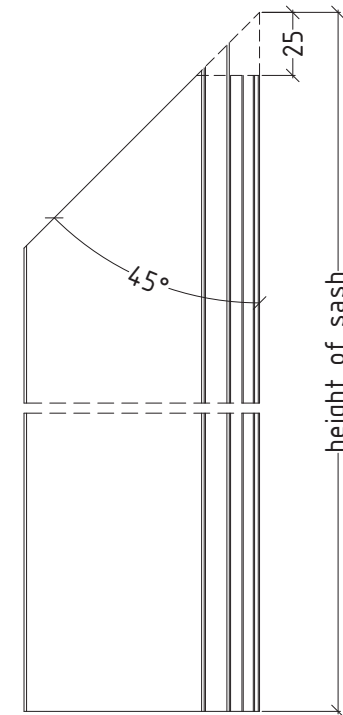

not to scale

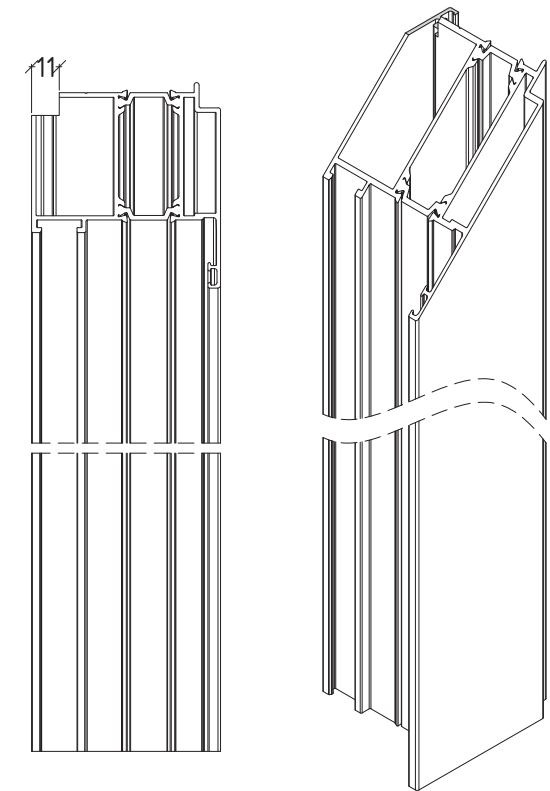

height of sash = H-61.5

M75D-17

flat door system with thermal break

E75FD

outward opening - double sash door

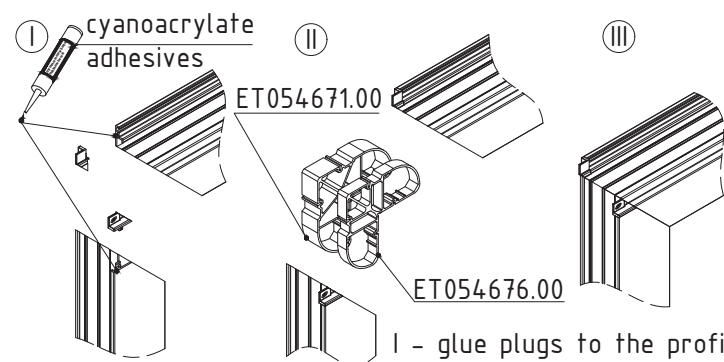
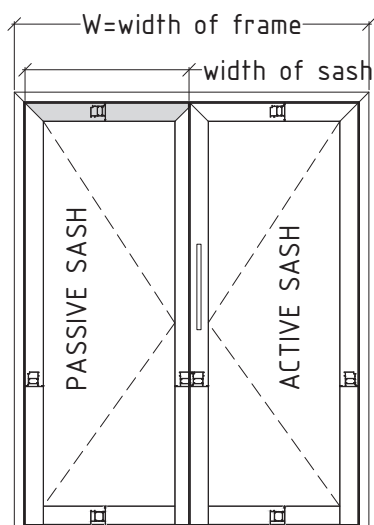

Sequence of assembly between sash-inward and sash-outward and specific joint corners usage

- I - glue plugs to the profile
- II - insert corner brackets in combination ET054671.00 + ET054676.00 for sash E75210 sash-inward + E75211 sash-outward
- III - crimp profiles

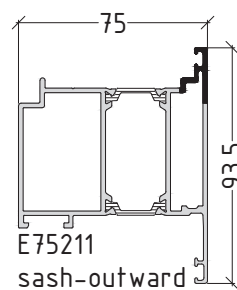
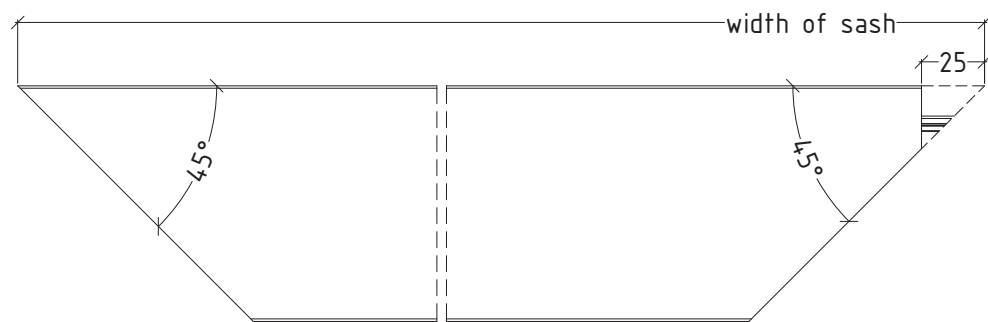
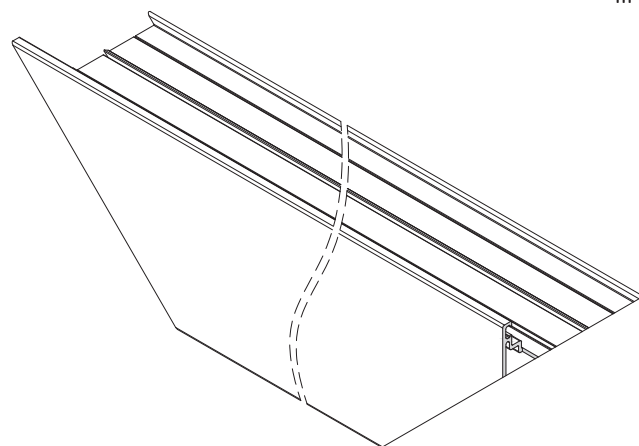

width of sash =  $\frac{W - 94}{2}$

not to scale

M75D-18

flat door system with thermal break

E75FD

outward opening - double sash door

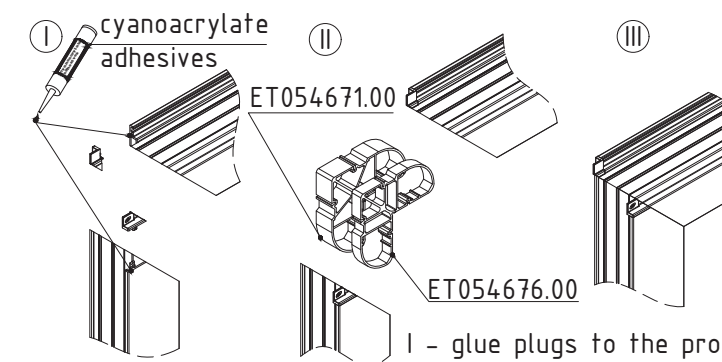
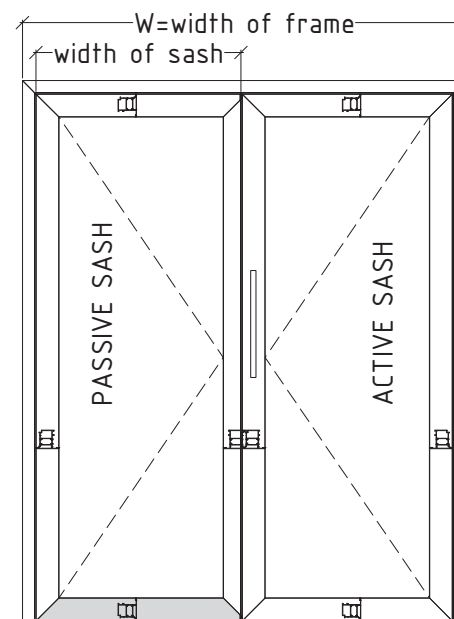

Sequence of assembly between sash-inward and sash-outward and specific joint corners usage

- I - glue plugs to the profile
- II - insert corner brackets in combination ET054671.00 + ET054676.00 for sash E75210 sash-inward + E75211 sash-outward
- III - crimp profiles

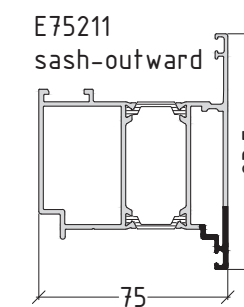
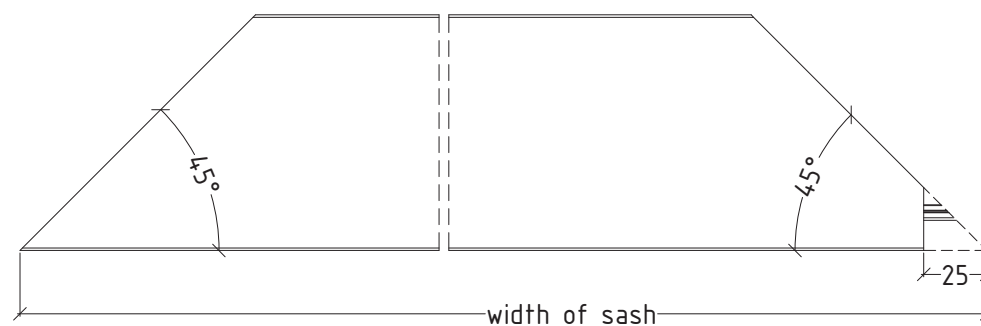
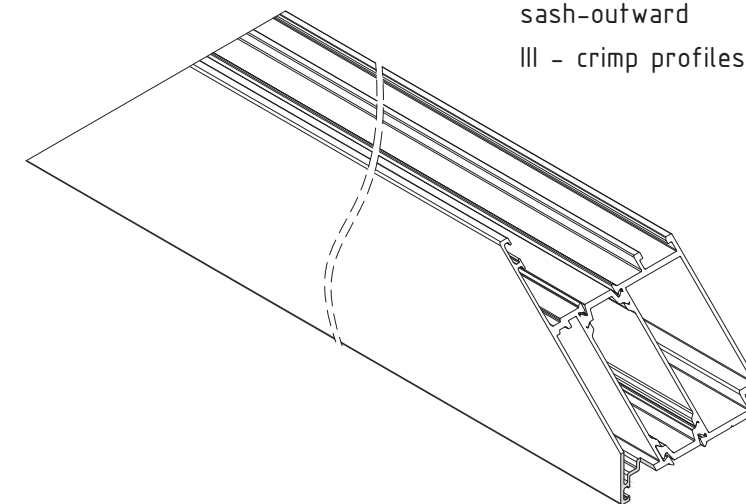

width of sash =  $\frac{W - 94}{2}$

not to scale

M75D-19

outward opening - double sash door

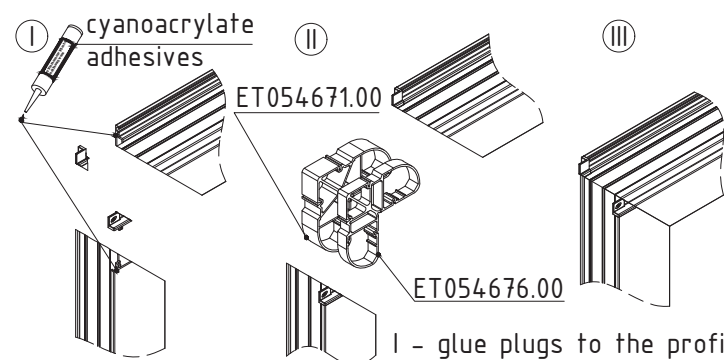
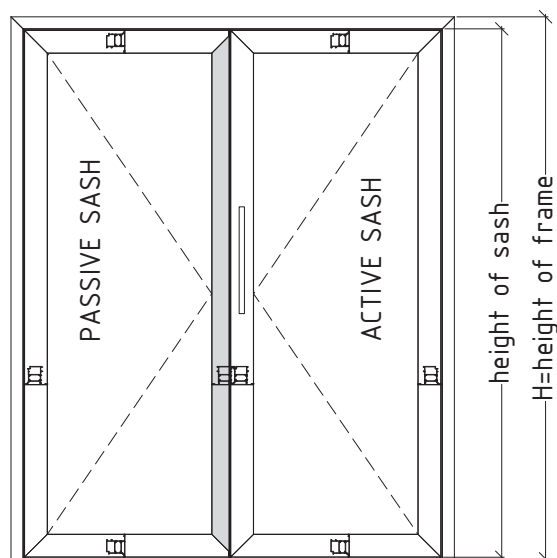

Sequence of assembly between sash-inward and sash-outward and specific joint corners usage

- I - glue plugs to the profile
- II - insert corner brackets in combination ET054671.00 + ET054676.00 for sash E75210 sash-inward + E75211 sash-outward
- III - crimp profiles

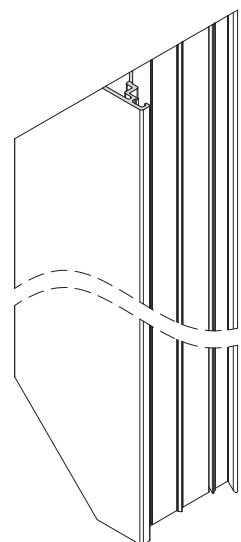

These machinings are for door with brush holder E75800 and E75805 threshold

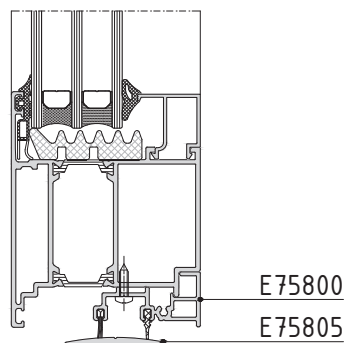

height of sash = H-61.5

M75D-20

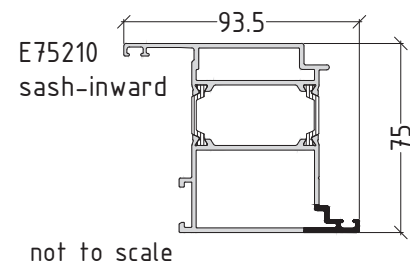

outward opening - double sash door

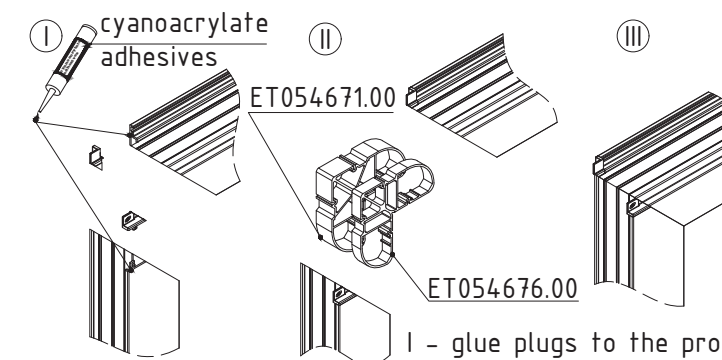
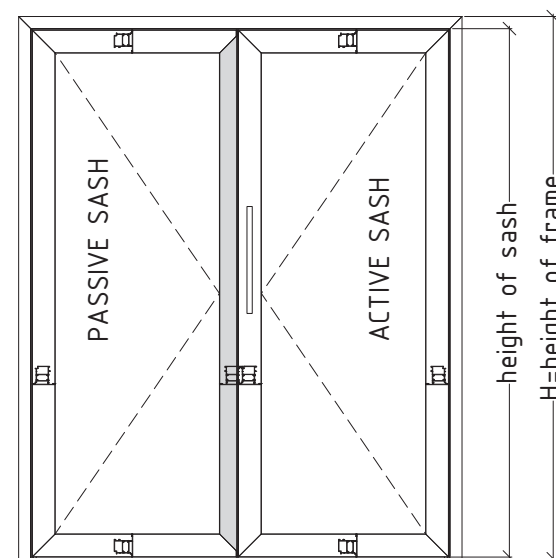

Sequence of assembly between sash-inward and sash-outward and specific joint corners usage

- I - glue plugs to the profile
- II - insert corner brackets in combination ET054671.00 + ET054676.00 for sash E75210 sash-inward + E75211 sash-outward
- III - crimp profiles

Machinings on the bottom and upper side are different

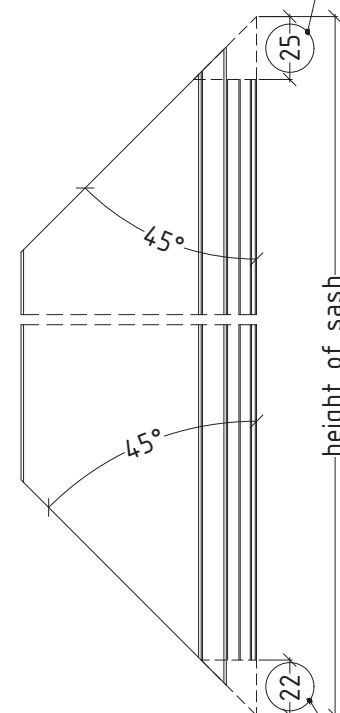

Machinings on the bottom and upper side are different

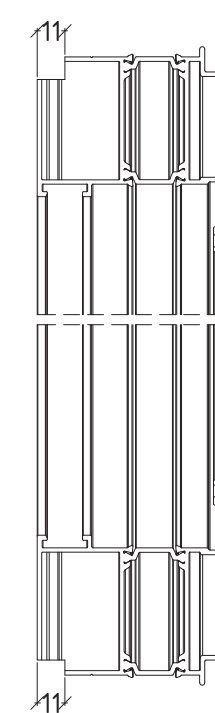
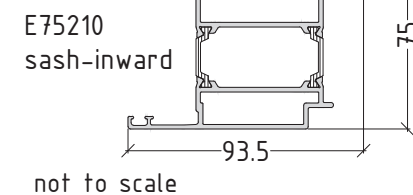

These machinings are for door with threshold E75810 or E75811

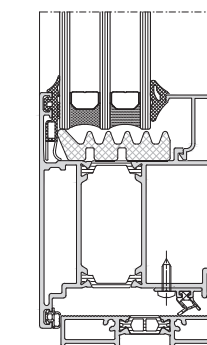

height of sash = H-61.5

M75D-21

outward opening - double sash door

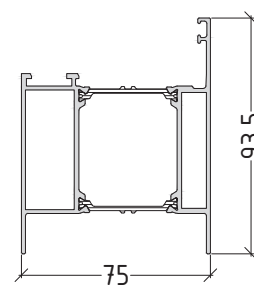
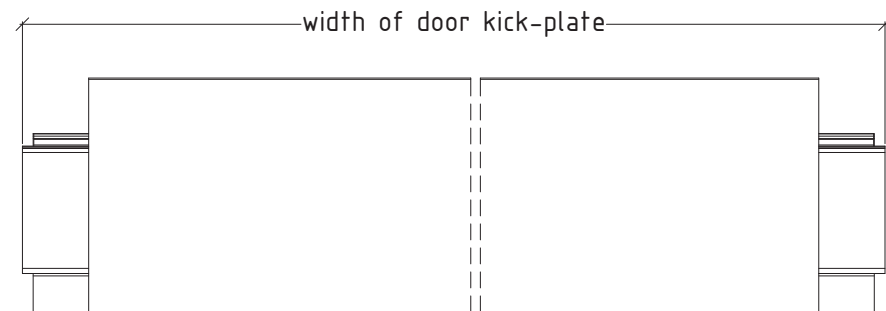
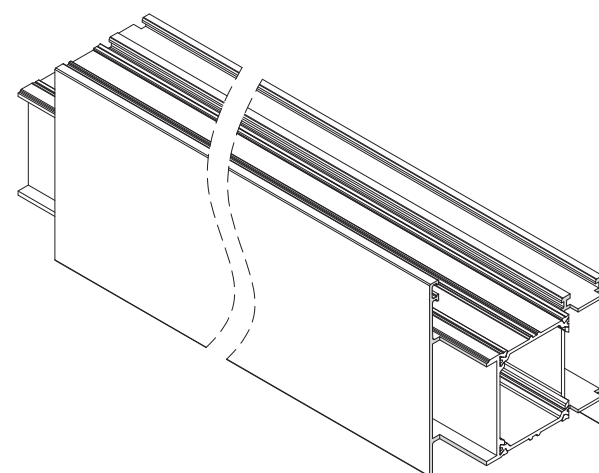
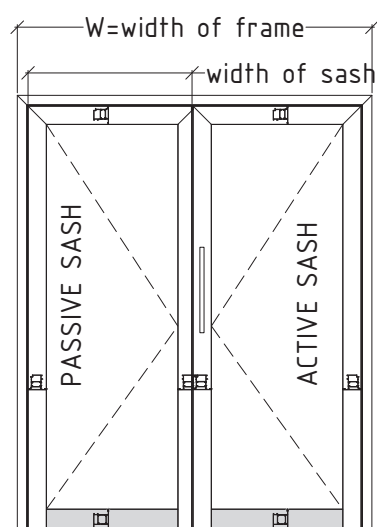

E75120 OR E75121 door kick-plate

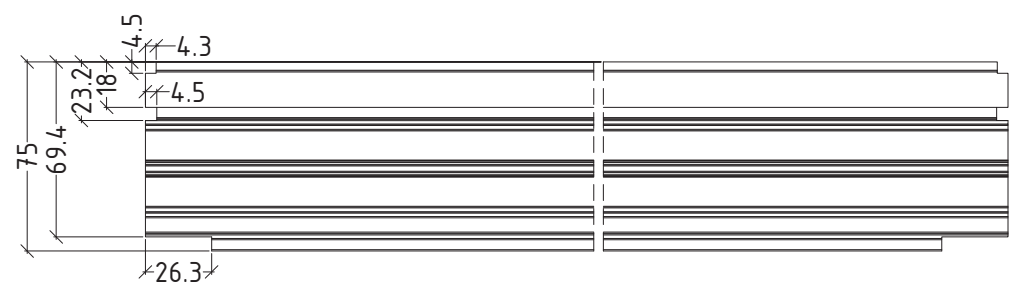
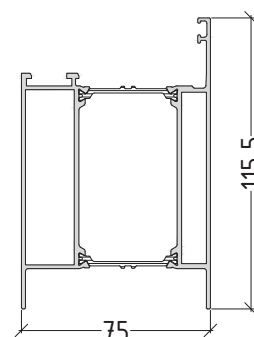
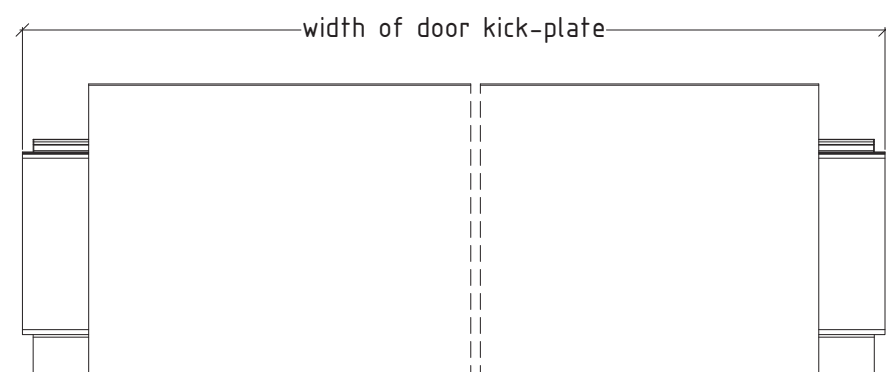

not to scale

width of door kick-plate = width of sash-134,5

M75D-22

inward opening - double sash door





profile selection		calculation of cutting length for two sash door		
profile selection		pieces	cutting formula	cutting angles
E75110 frame-inward 	width of frame	1	W	2x45°
	height of frame-left	1	H	1x45° + 1x90° up down
	height of frame-right	1	H	1x45° + 1x90° up down
E75210 sash-inward 	width of sash-inward	2	$\frac{W - 94}{2}$	2x45°
	height of sash-inward	2 +	H - 61.5	1x45° + 1x90° up down
E75211 sash-outward 	height of sash-outward	1	H - 61.5	1x45° + 1x90° up down
option 1				
E75120 door kick-plate 	width of door kick-plate	2	width of sash-134,5	2x90°
option 2				
E75121 door kick-plate 	width of door kick-plate	2	width of sash-134,5	2x90°

not to scale

M75D-23

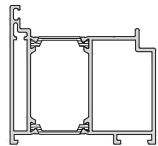
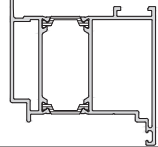
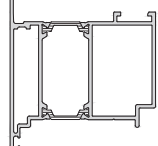

inward opening - double sash door



profile selection		calculation of cutting length for two sash door		
profile selection		pieces	cutting formula	cutting angles
E75110 frame-inward 	width of frame	1	W	2x45°
	height of frame-left	1	H	1x45° + 1x90° up down
	height of frame-right	1	H	1x45° + 1x90° up down
E75210 sash-inward 	width of sash-inward	4	$\frac{W - 94}{2}$	2x45°
	height of sash-inward	2 + 1	H - 61.5	2x45°
E75211 sash-outward 	height of sash-outward	1	H - 61.5	2x45°
option 1				
E75810 or E75811 	width of door threshold	1	W - 143	2x90°
E75802 bottom rail 	width of bottom rail	2	width of sash-32	2x90°
E75801 	width of addition	1	width of sash-47 for active sash	2x90°
	width of addition	1	width of sash-25 for passive sash	2x90°

not to scale

M75D-24

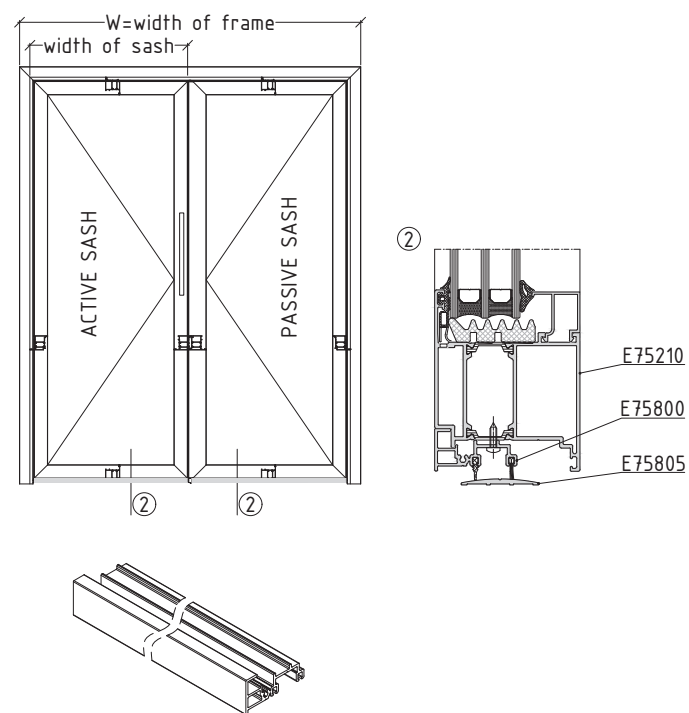
inward opening - double sash door



profile selection		calculation of cutting length for two sash door		
profile selection		pieces	cutting formula	cutting angles
option 2				
E75800 bottom rail 	width of bottom rail	1	width of sash-48 for active sash	2x90°
	width of bottom rail	1	width of sash-42 for passive sash	2x90°
E75805 - optional finish 	width of door threshold	1	W - 125	2x90°

not to scale

M75D-25

inward opening - double sash door

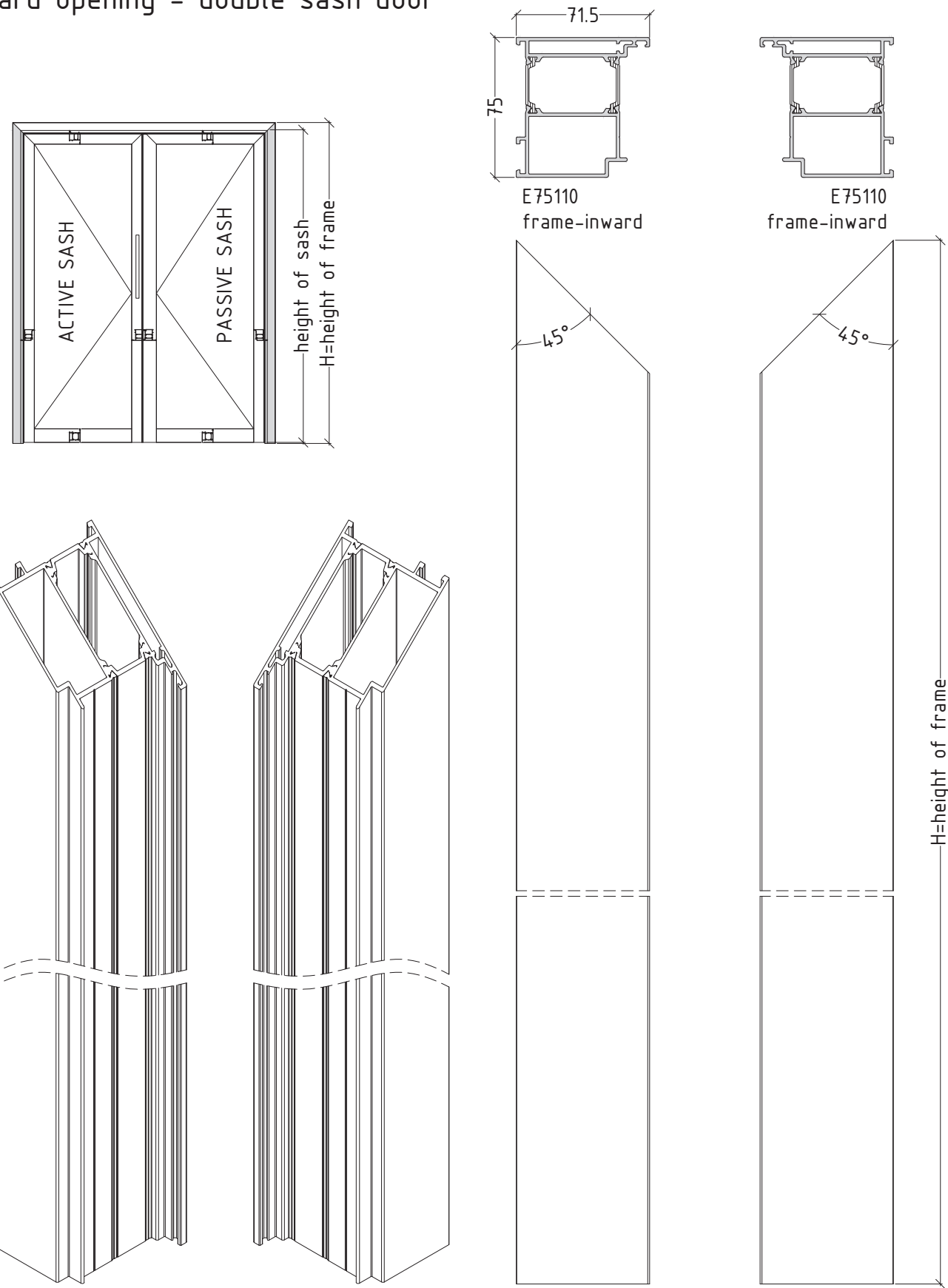

not to scale

M75D-26

inward opening - double sash door

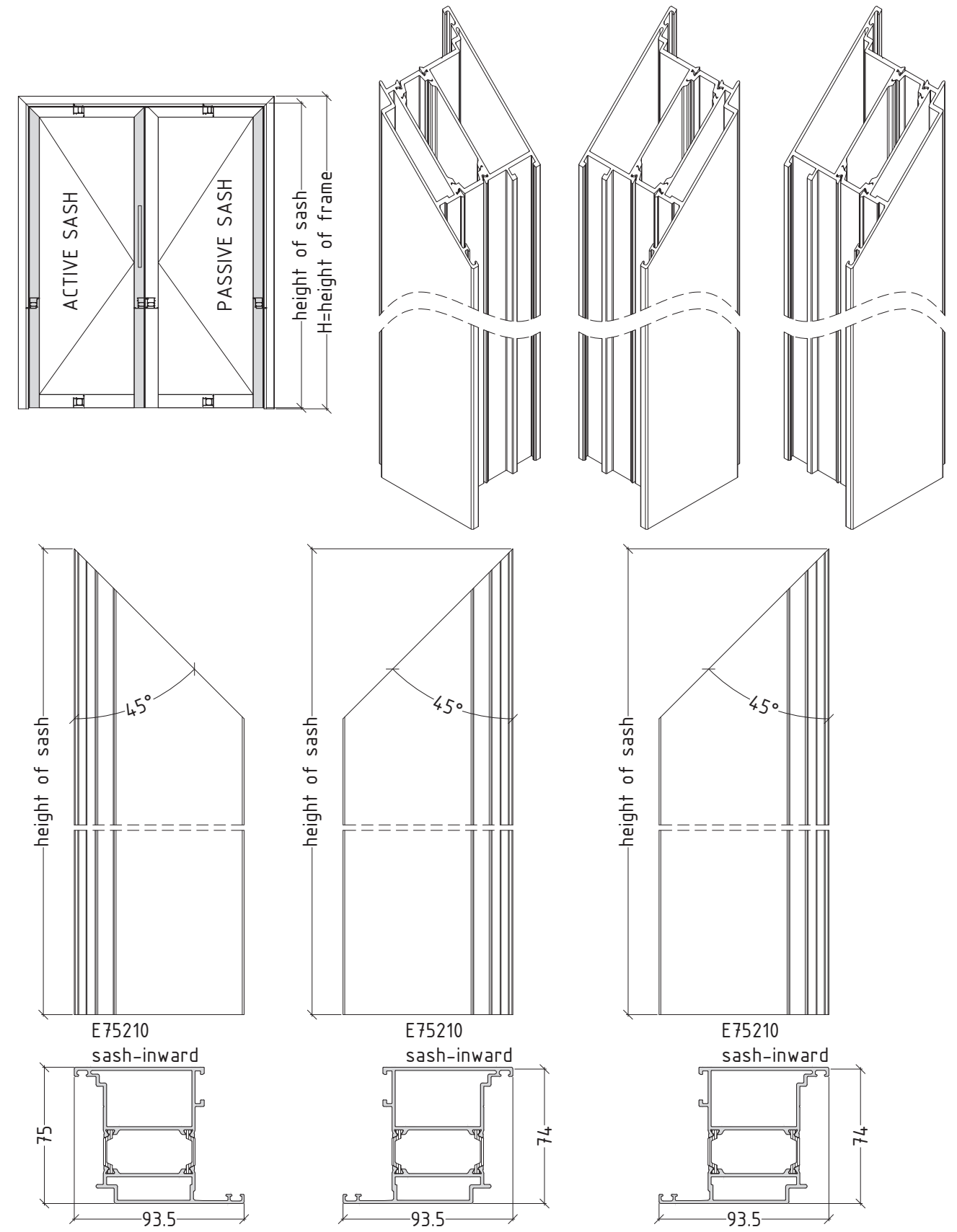

not to scale

height of sash = H-61.5

M75D-27

inward opening - double sash door

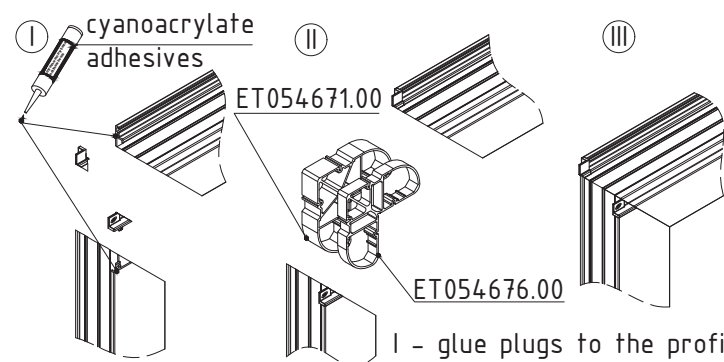
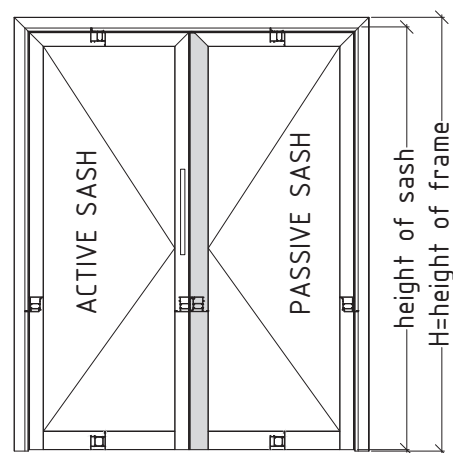

Sequence of assembly between sash-inward and sash-outward and specific joint corners usage

- I - glue plugs to the profile
- II - insert corner brackets in combination ET054671.00 + ET054676.00 for sash E75210 sash-inward + E75211 sash-outward
- III - crimp profiles

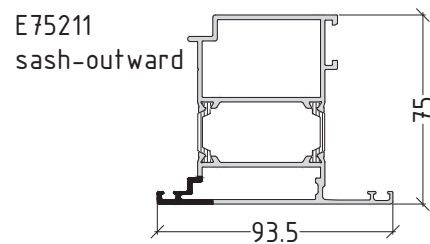
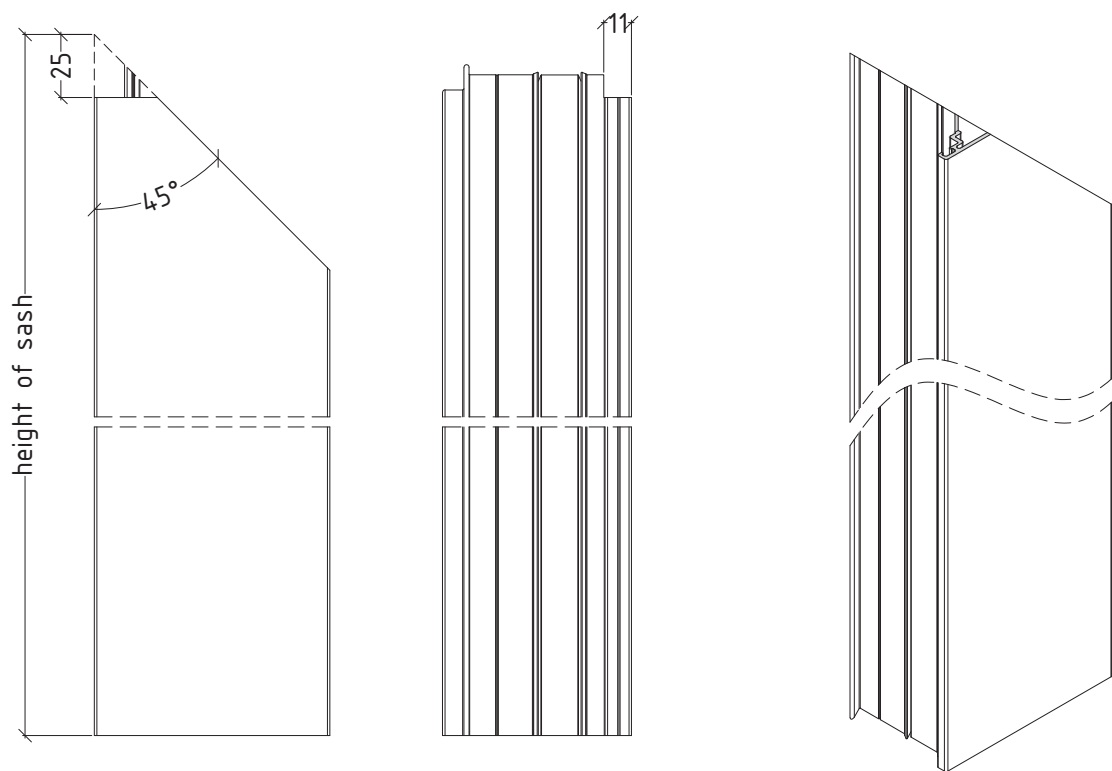

not to scale

height of sash = H-61.5

M75D-28

inward opening - double sash door

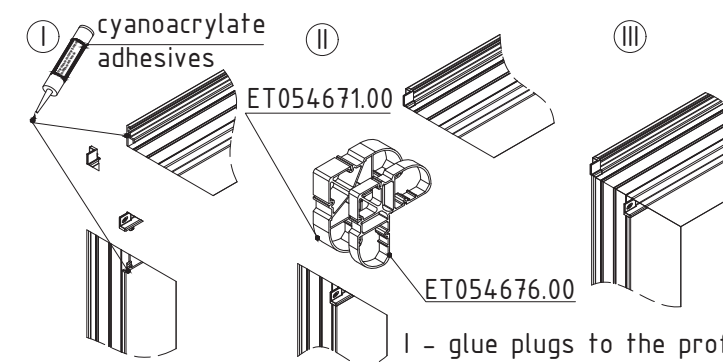
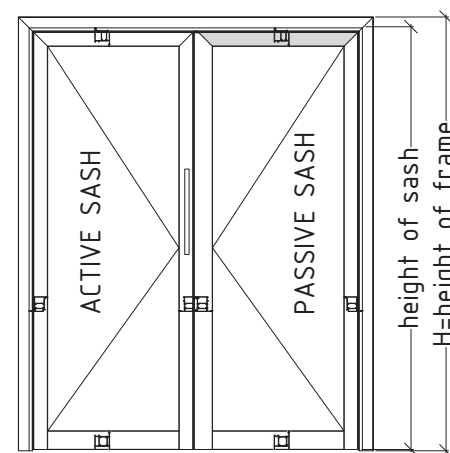

Sequence of assembly between sash-inward and sash-outward and specific joint corners usage

- I - glue plugs to the profile
- II - insert corner brackets in combination ET054671.00 + ET054676.00 for sash E75210 sash-inward + E75211 sash-outward
- III - crimp profiles

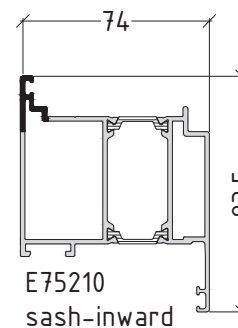
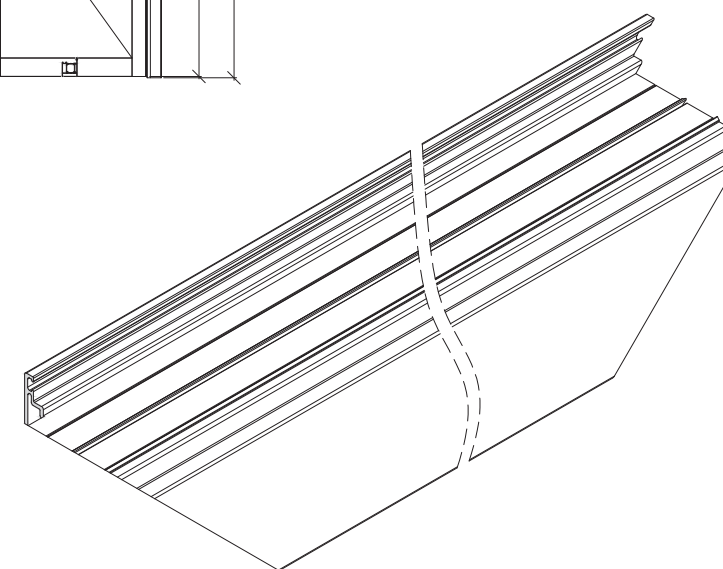

E75210 sash-inward

not to scale

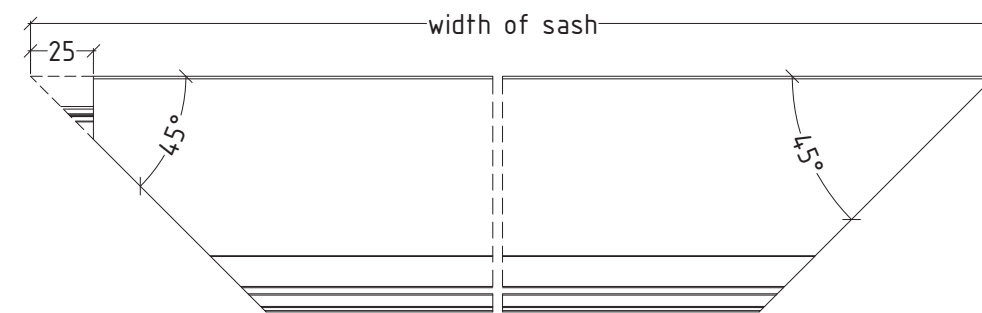

width of sash =  $\frac{W - 94}{2}$

M75D-29

inward opening - double sash door

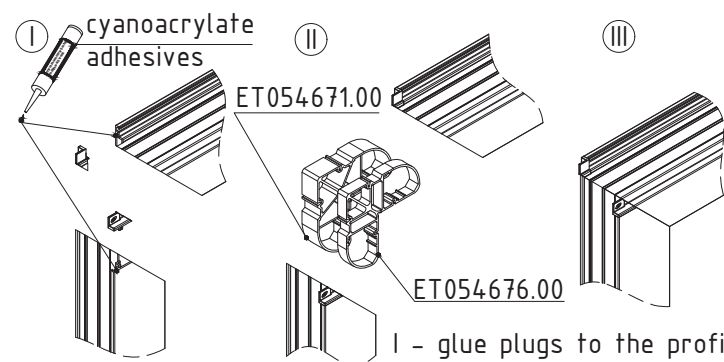
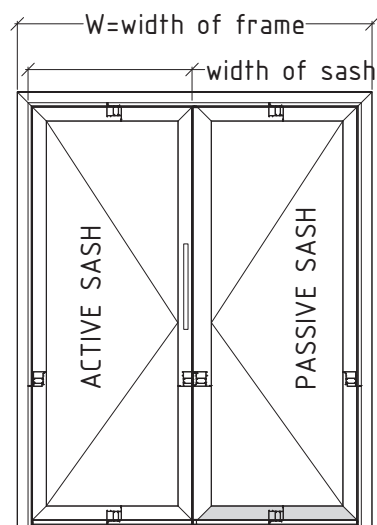

Sequence of assembly between sash-inward and sash-outward and specific joint corners usage

- I - glue plugs to the profile
- II - insert corner brackets in combination ET054671.00 + ET054676.00 for sash E75210 sash-inward + E75211 sash-outward
- III - crimp profiles

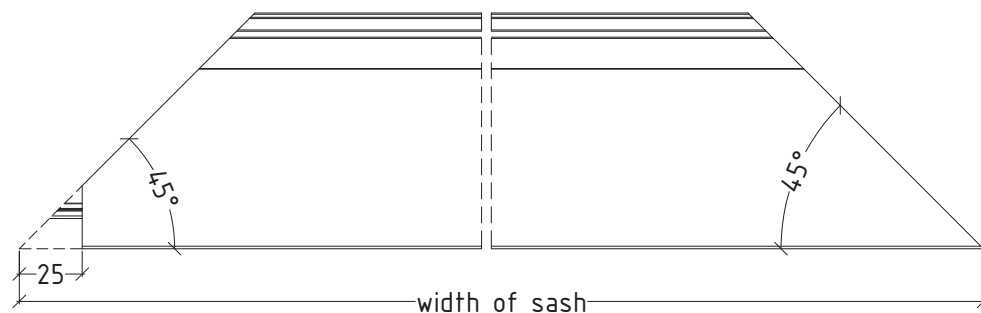
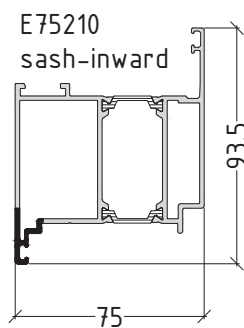
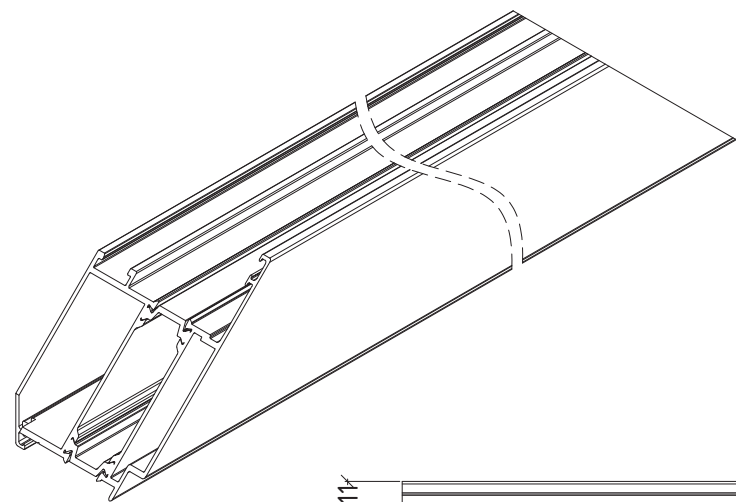

$$\text{width of sash} = \frac{W - 94}{2}$$

not to scale

M75D-30

inward opening - double sash door

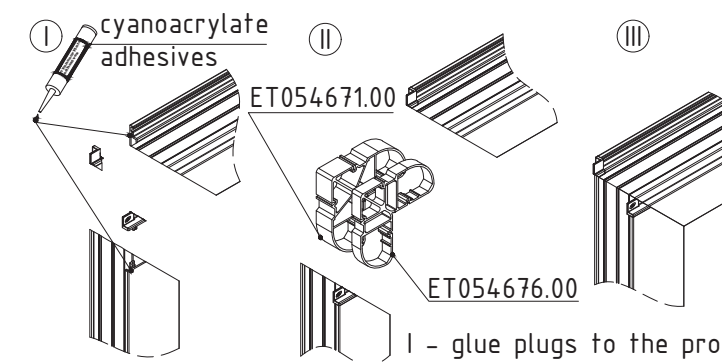
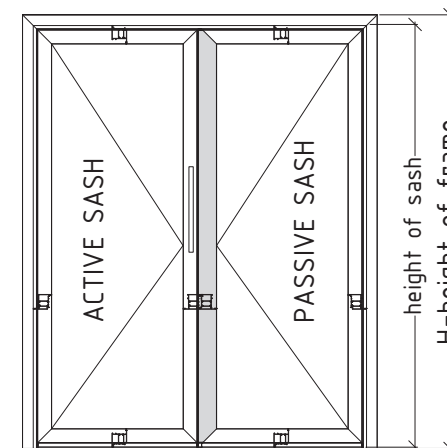

Sequence of assembly between sash-inward and sash-outward and specific joint corners usage

- I - glue plugs to the profile
- II - insert corner brackets in combination ET054671.00 + ET054676.00 for sash E75210 sash-inward + E75211 sash-outward
- III - crimp profiles

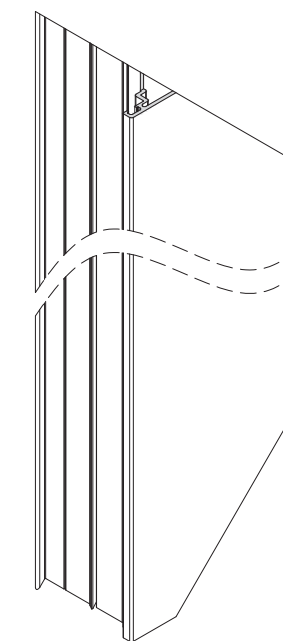
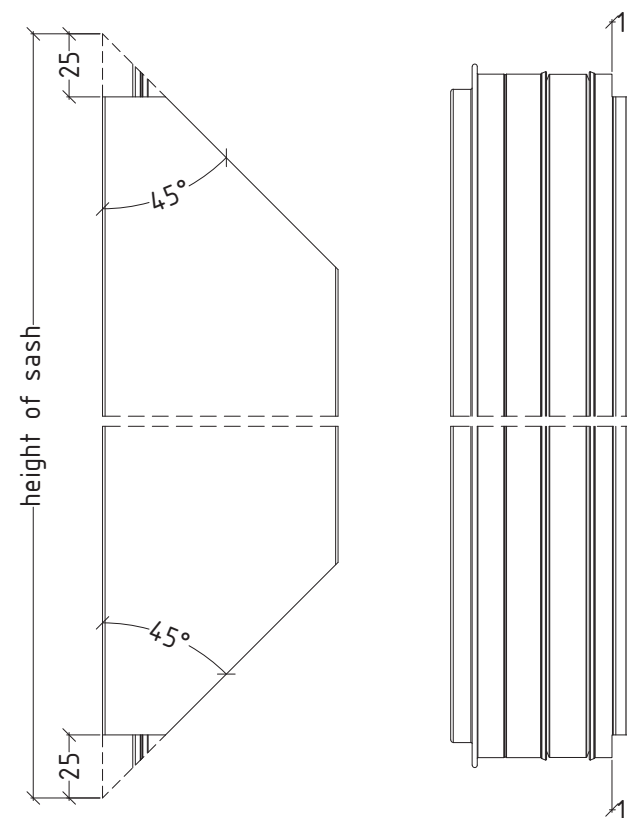

These machinings are for door with brush holder E75800 and E75805 threshold

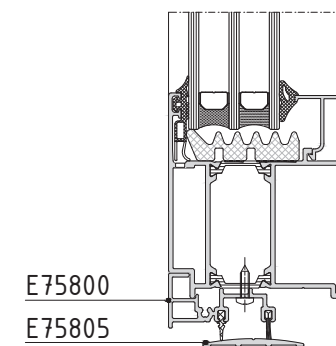
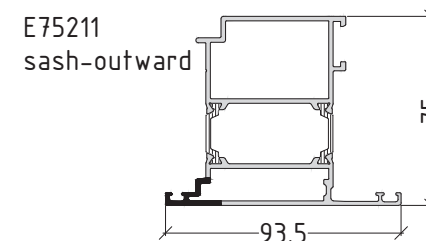

not to scale

height of sash = H-61.5

M75D-31

inward opening - double sash door

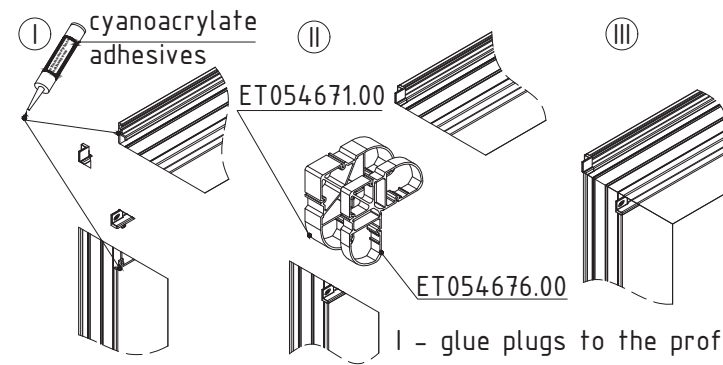
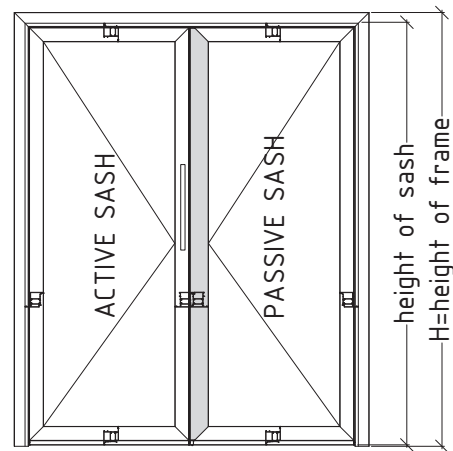

Sequence of assembly between sash-inward and sash-outward and specific joint corners usage

- I - glue plugs to the profile ET054671.00
- II - insert corner brackets in combination ET054671.00 + ET054676.00 for sash E75210 sash-inward + E75211 sash-outward
- III - crimp profiles

Machinings on the bottom and upper side are different

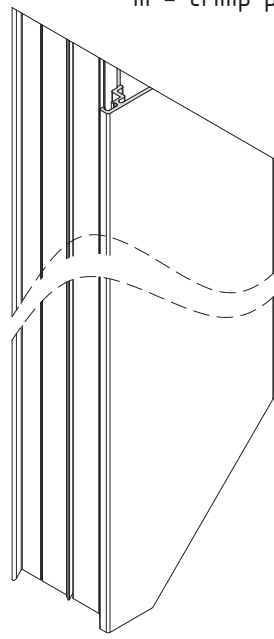
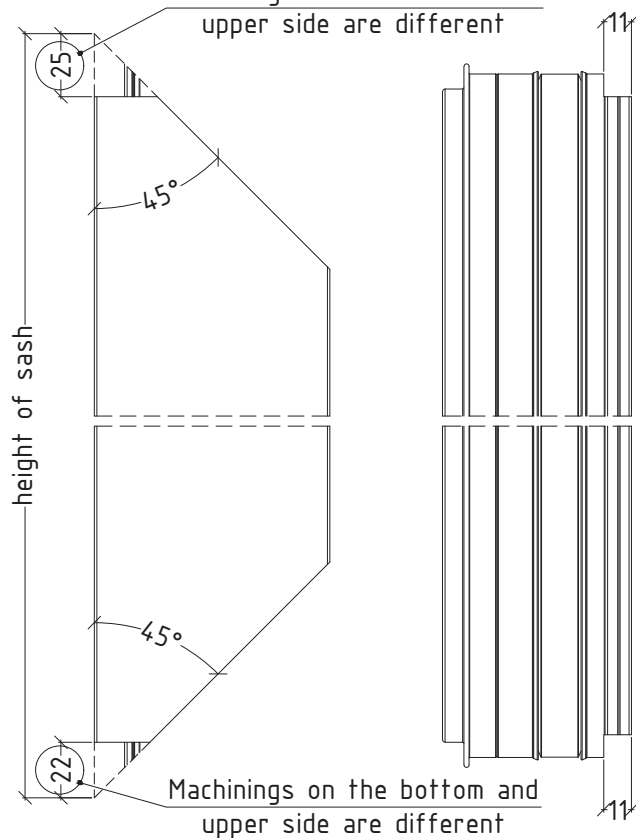

These machinings are for door with threshold E75810 or E75811

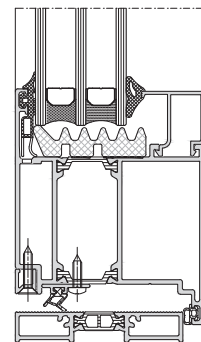

height of sash = H-61.5

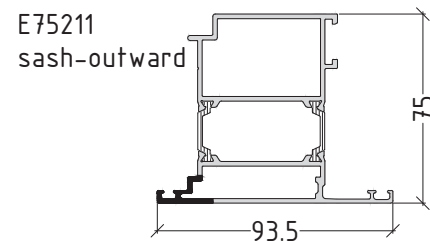

not to scale

M75D-32

inward opening - double sash door

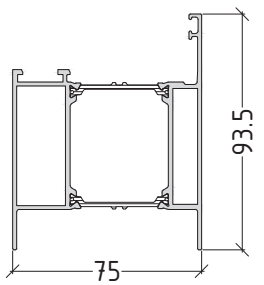
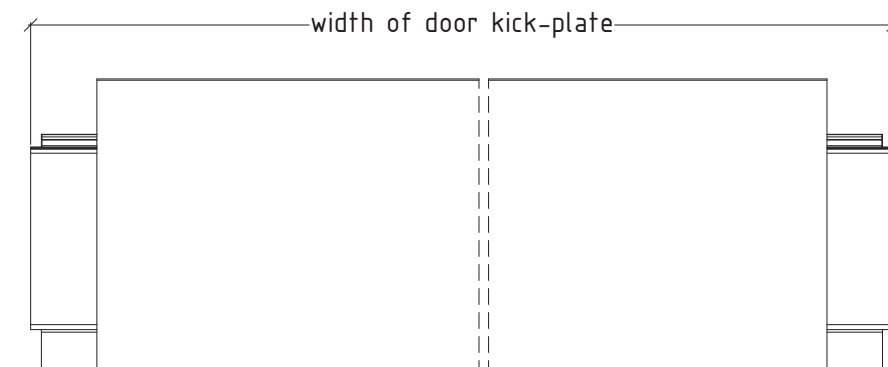
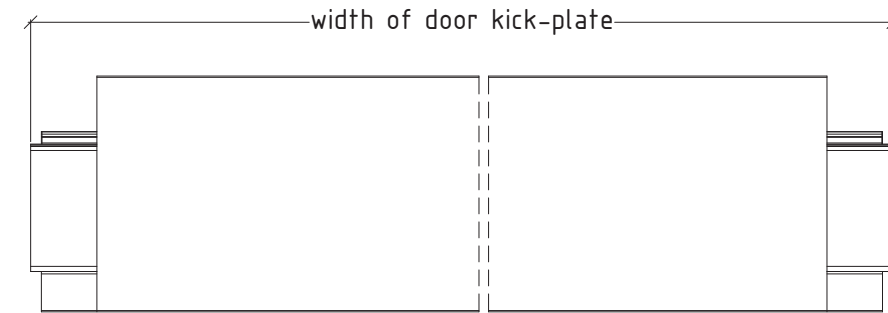
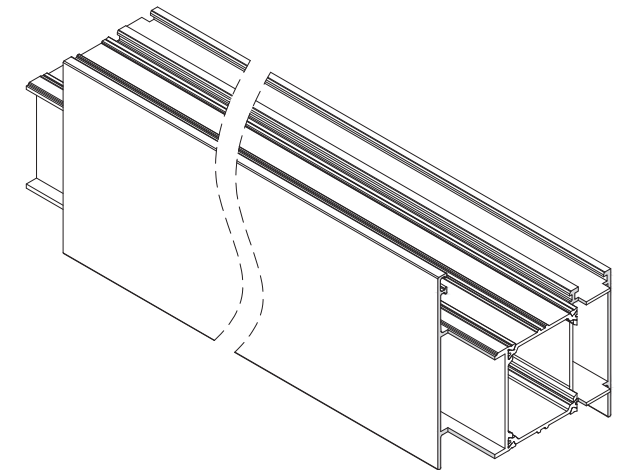
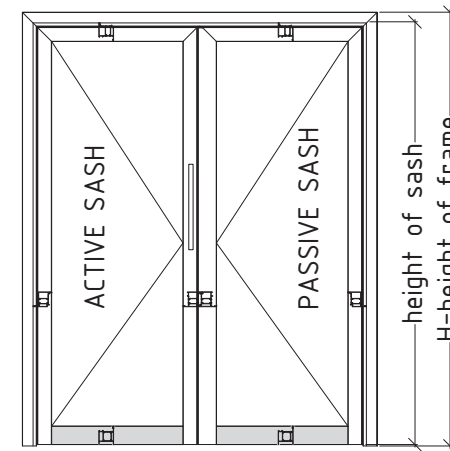

E75120 or E75121 door kick-plate

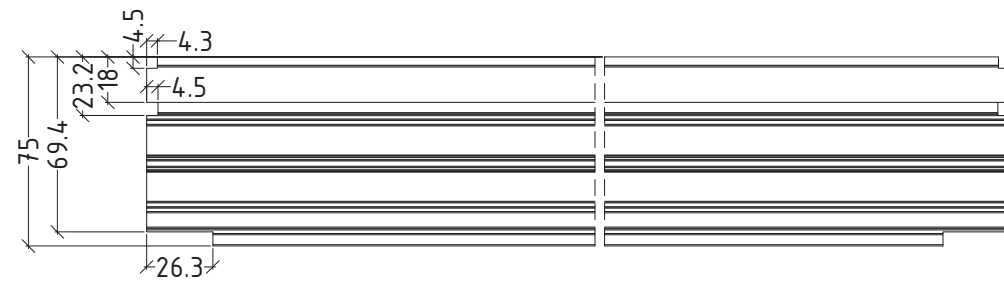
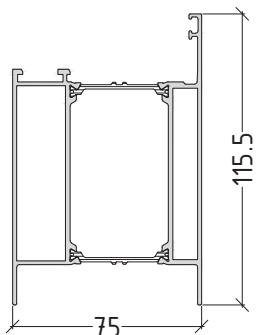

not to scale

width of door kick-plate= width of sash-134,5

M75D-33

outward opening double sash door

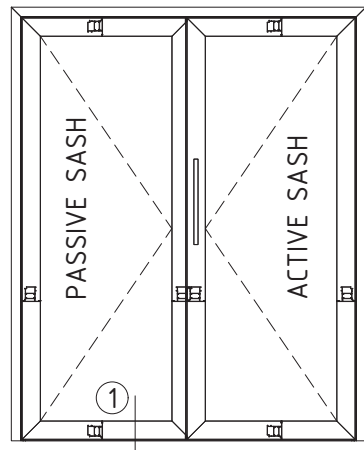

inward opening double sash door

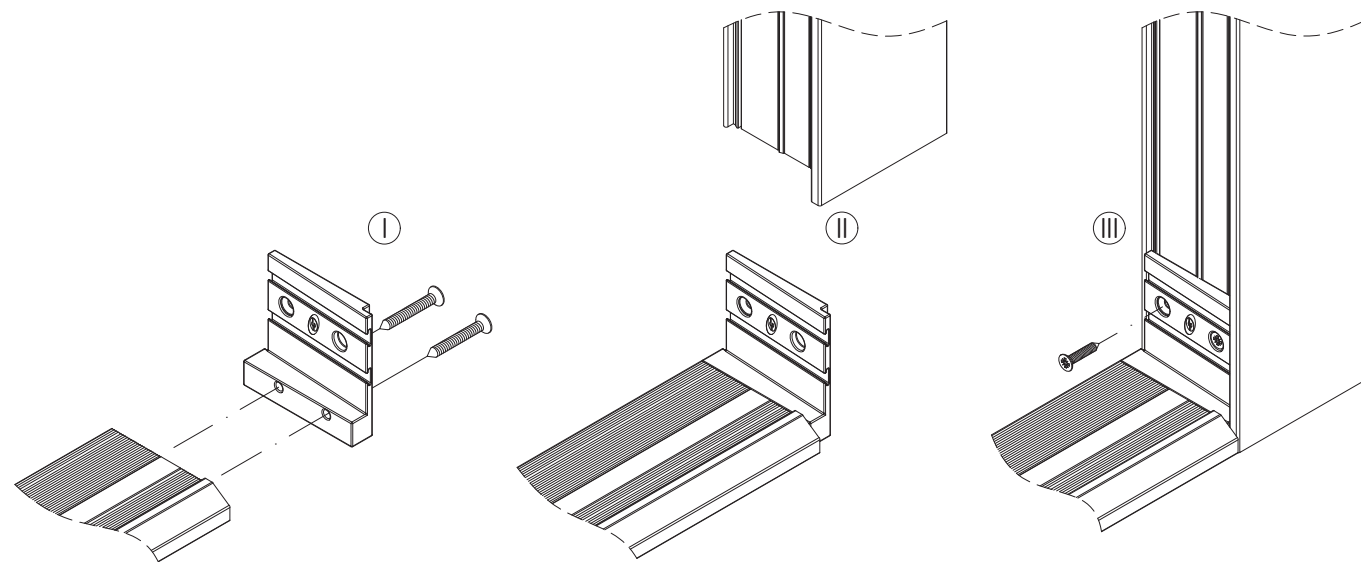
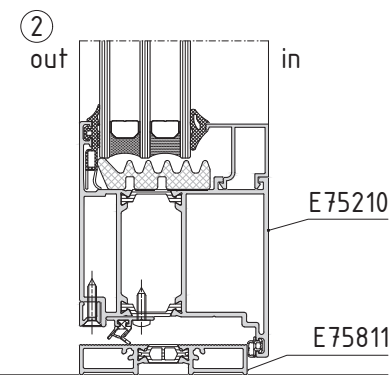
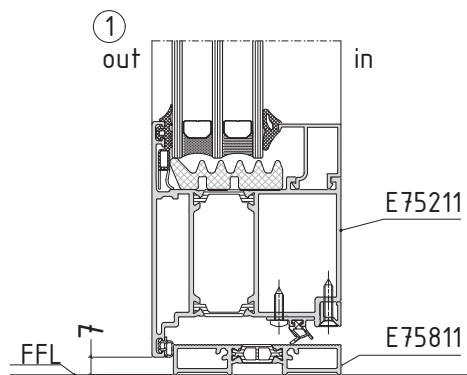
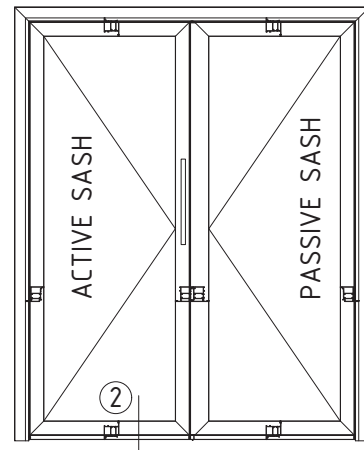

not to scale

M75D-34

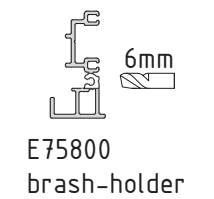
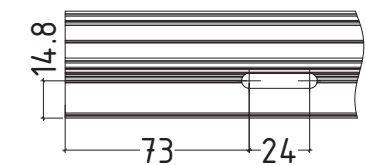
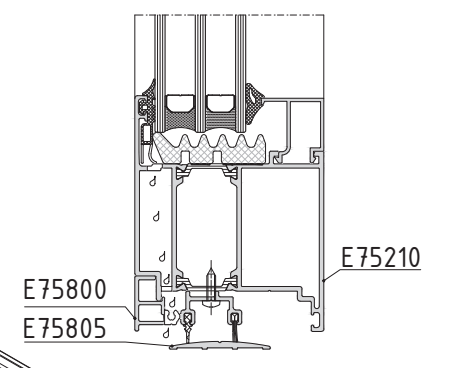
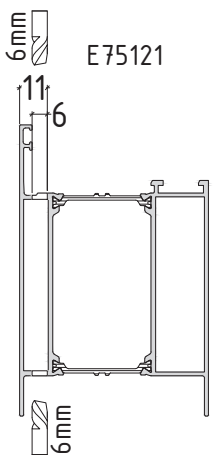
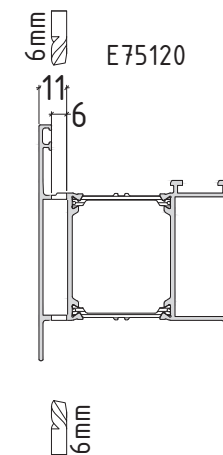
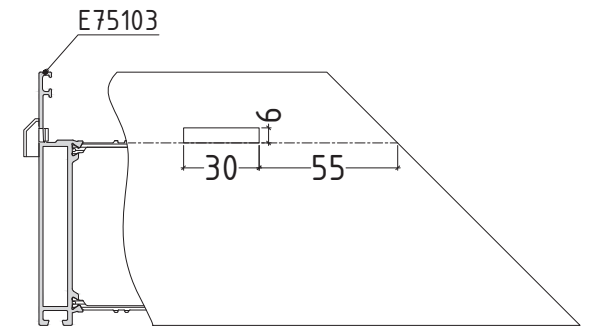
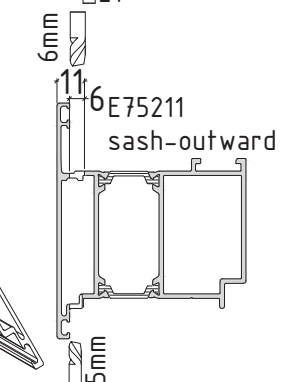
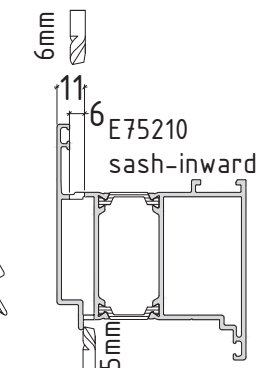
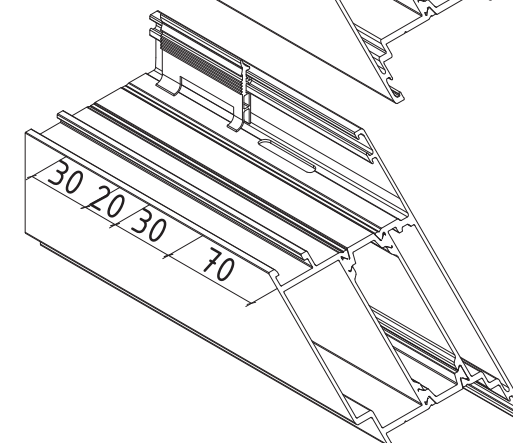
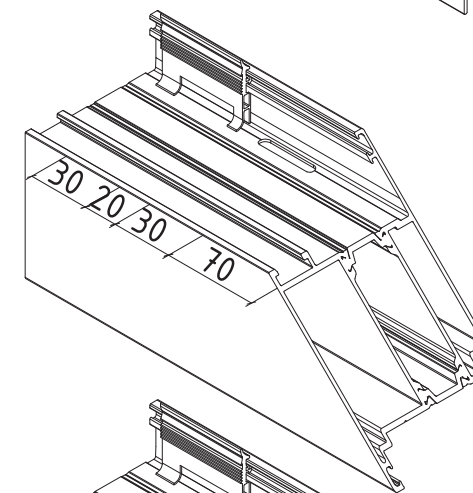
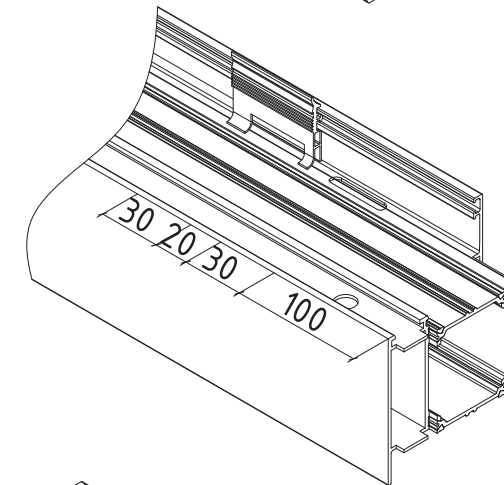
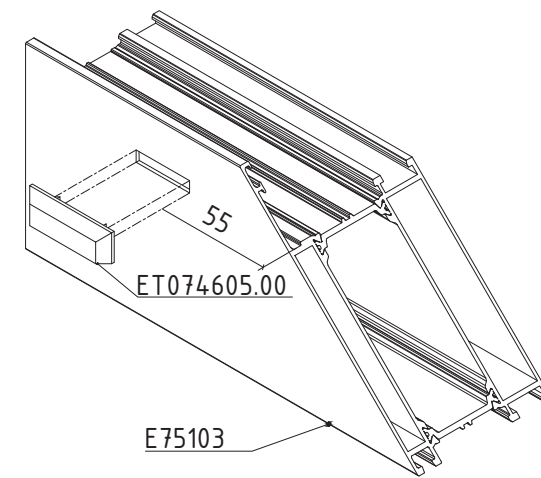

not to scale

M75D-35

flat door system with thermal break

E75FD

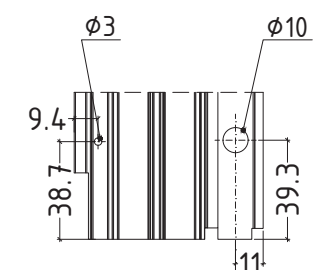
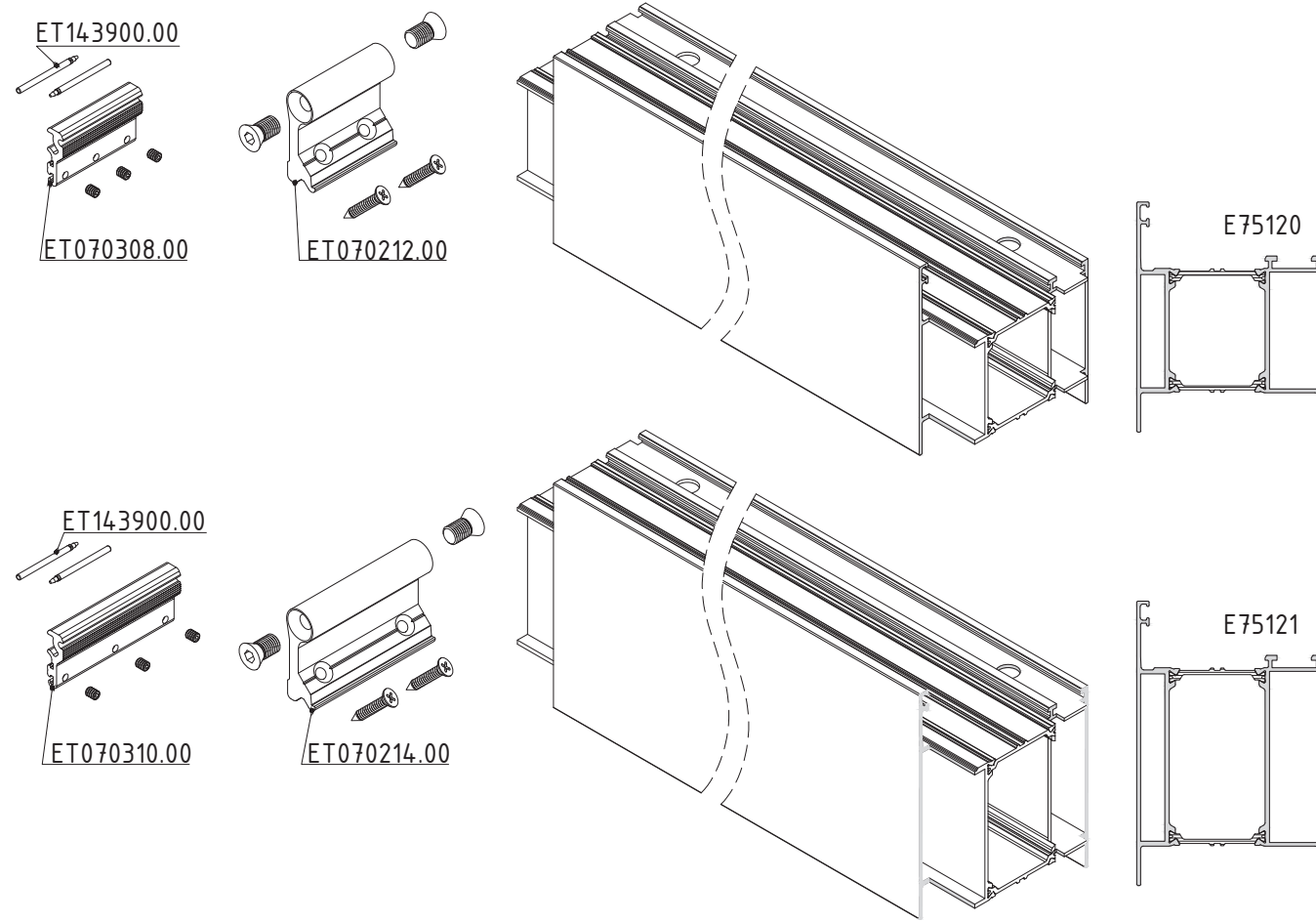

Apply silicone to the indicated place before final frame assembly

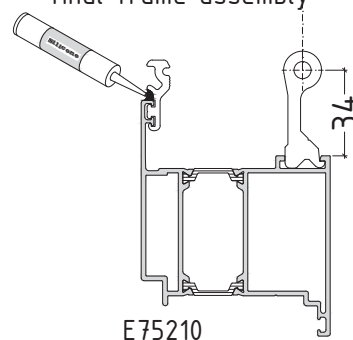

E75210  
sash-inward

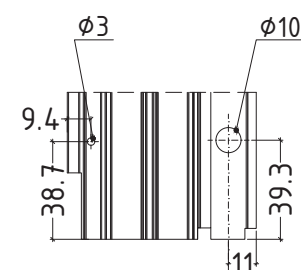

Apply silicone to the indicated place before final frame assembly

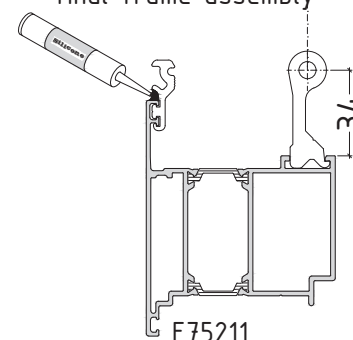

E75211  
sash-outward

not to scale

M75D-36

flat door system with thermal break

E75FD

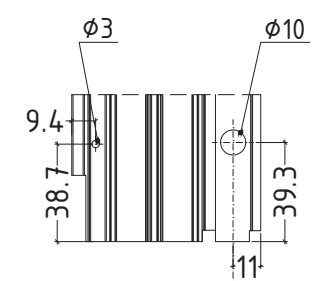
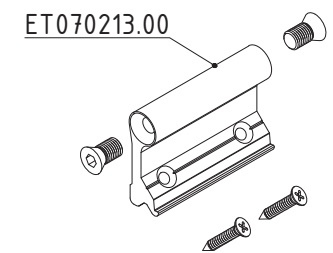
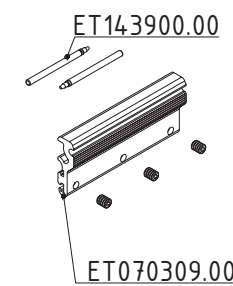
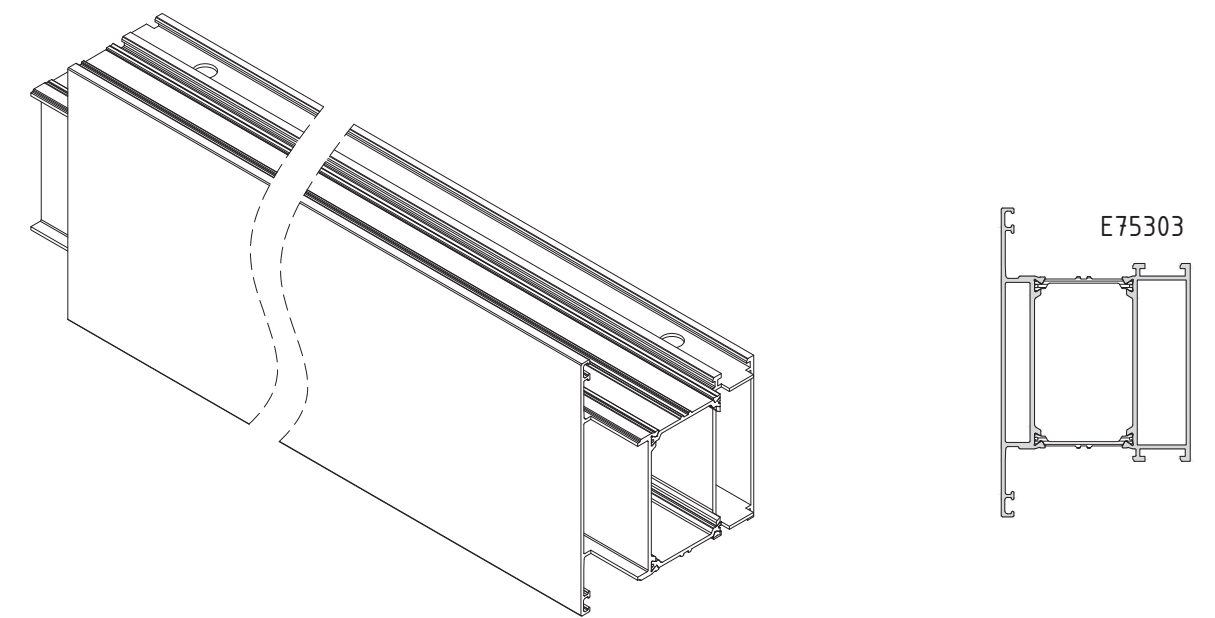

Apply silicone to the indicated place before final frame assembly

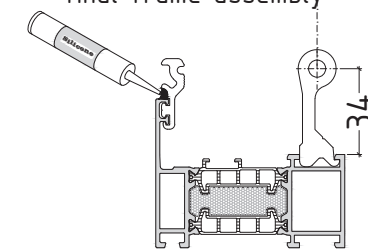

E75100  
E75101  
E75102  
E75105  
frame

not to scale

M75D-37

outward opening  
double sash door

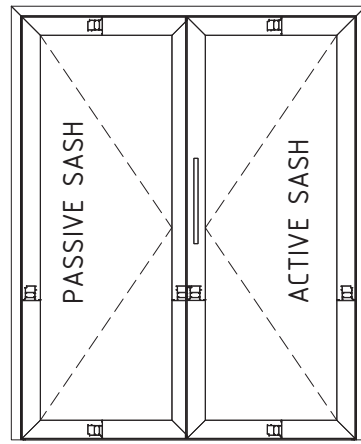

inward opening  
double sash door

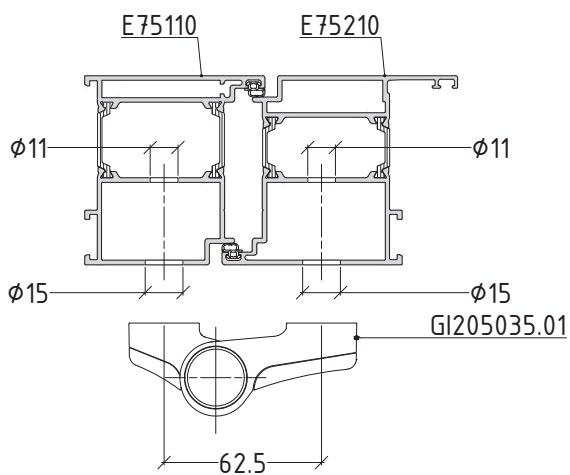
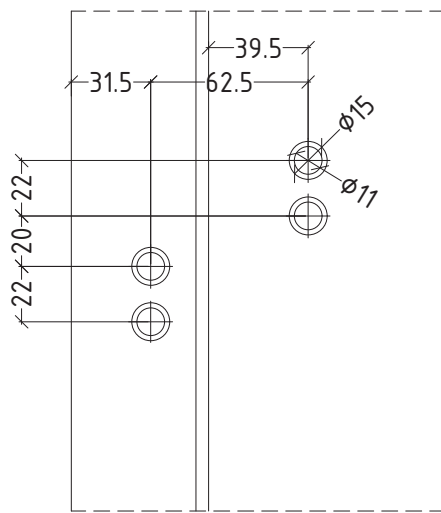
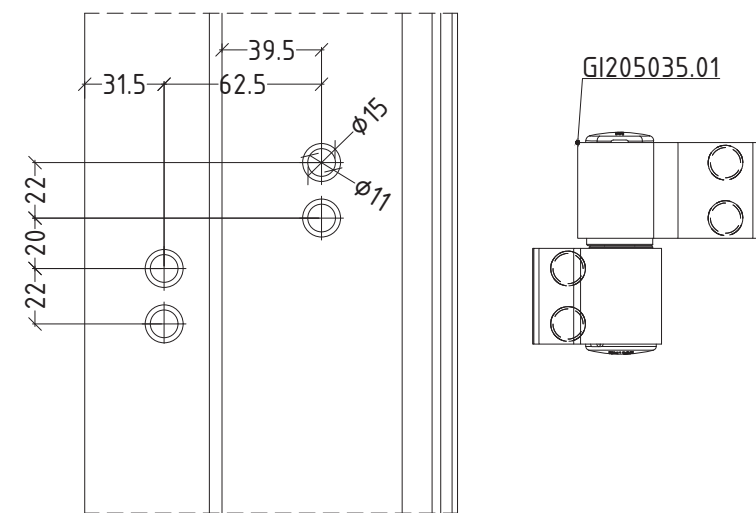
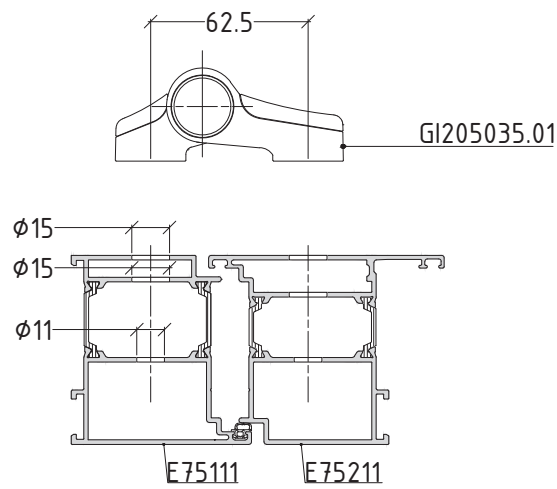
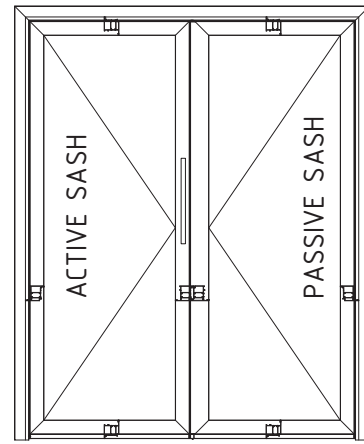

\* The dimensions refer to anodized and mill-finished profiles!

For powder coated profiles, the thickness of the coating must be taken into account!  
not to scale

M75D-38

outward opening  
double sash door

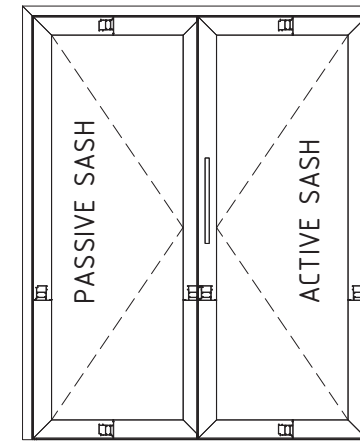

inward opening  
double sash door

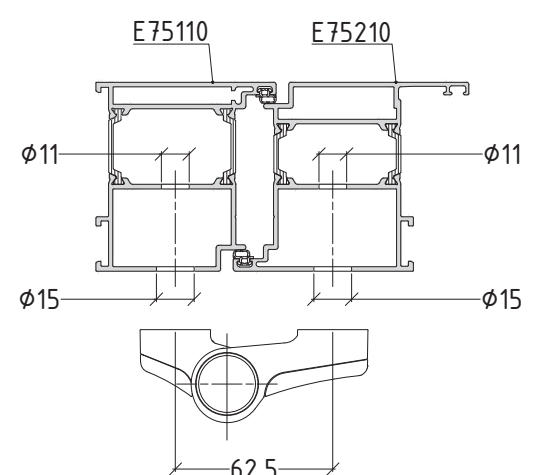
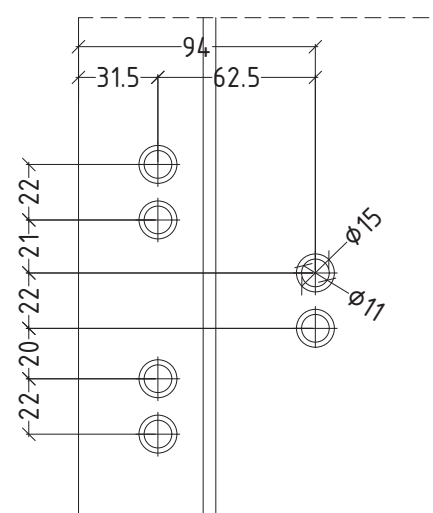
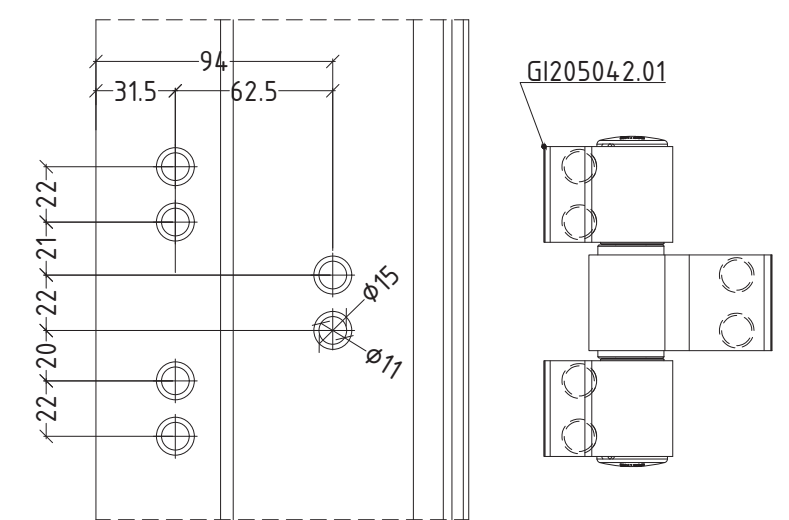
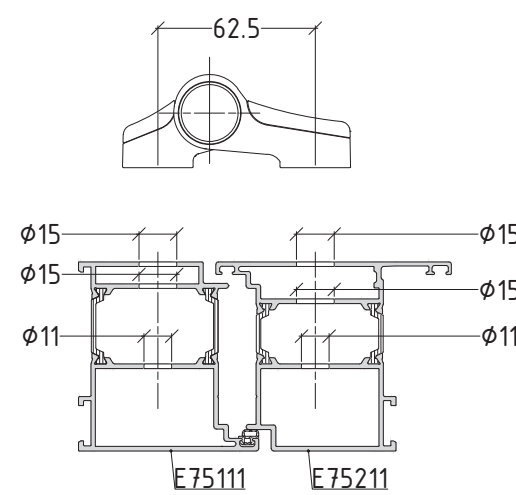
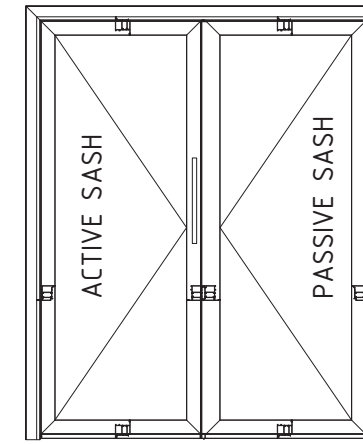

\* The dimensions refer to anodized and mill-finished profiles!

For powder coated profiles, the thickness of the coating must be taken into account!  
not to scale

M75D-39



outward opening  
double sash door

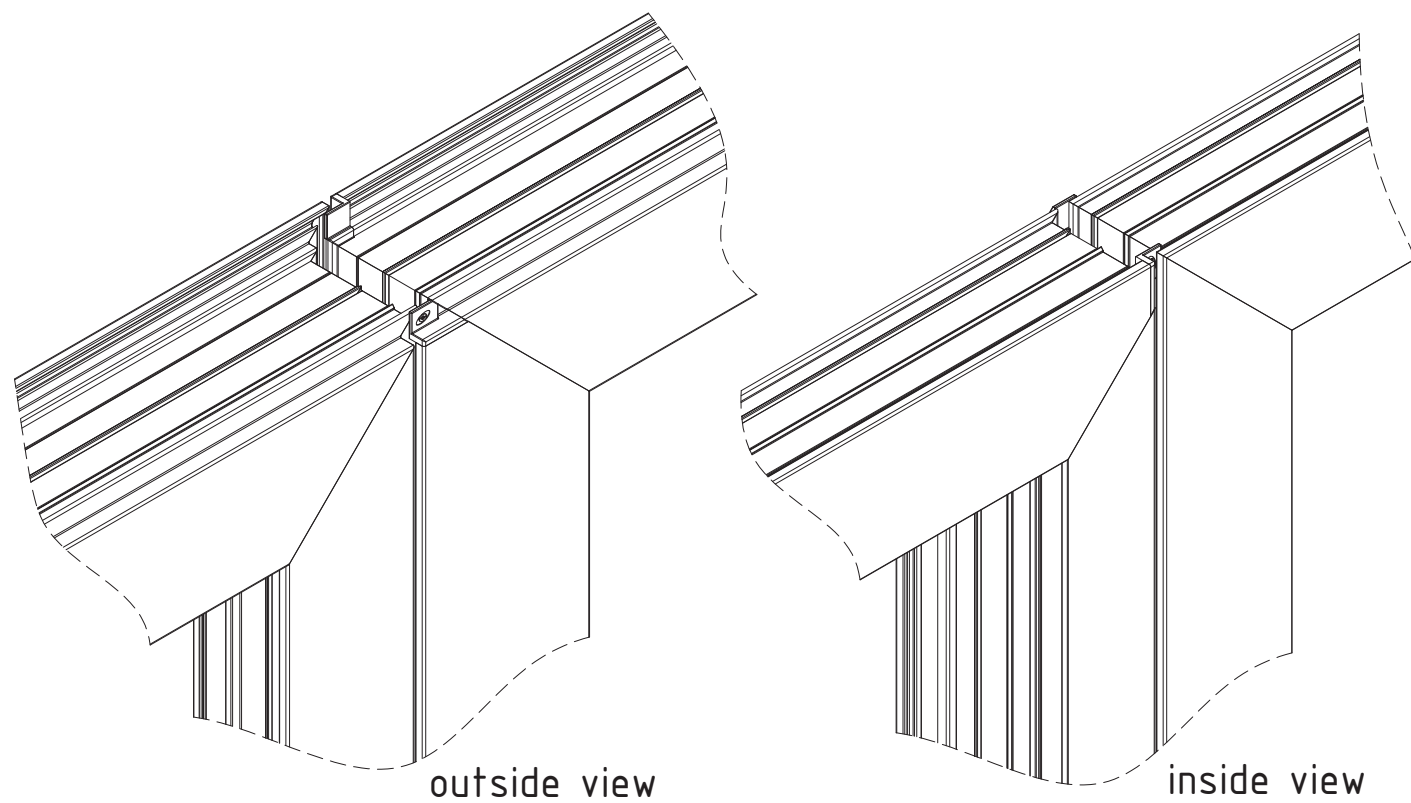
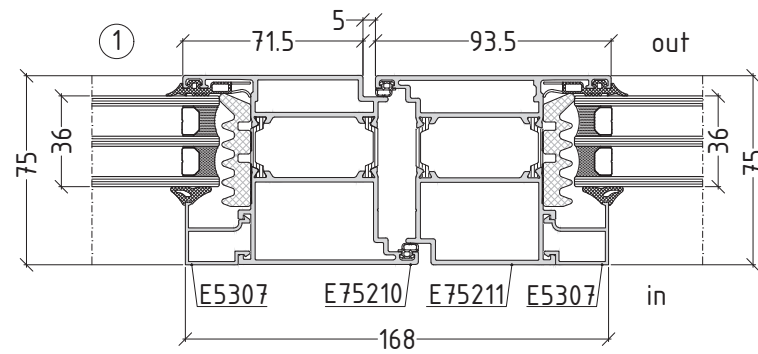
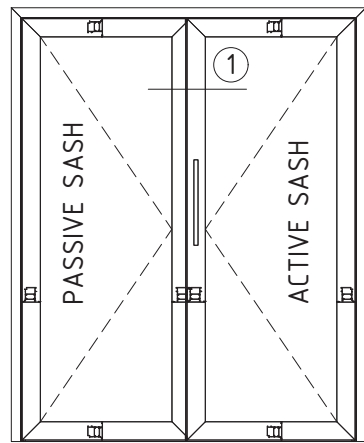

Note:

This central section of double sash door is equal for outward opening and inward opening.

not to scale

M75D-40

outward opening - double sash door  
combination - E75 flat door + E75

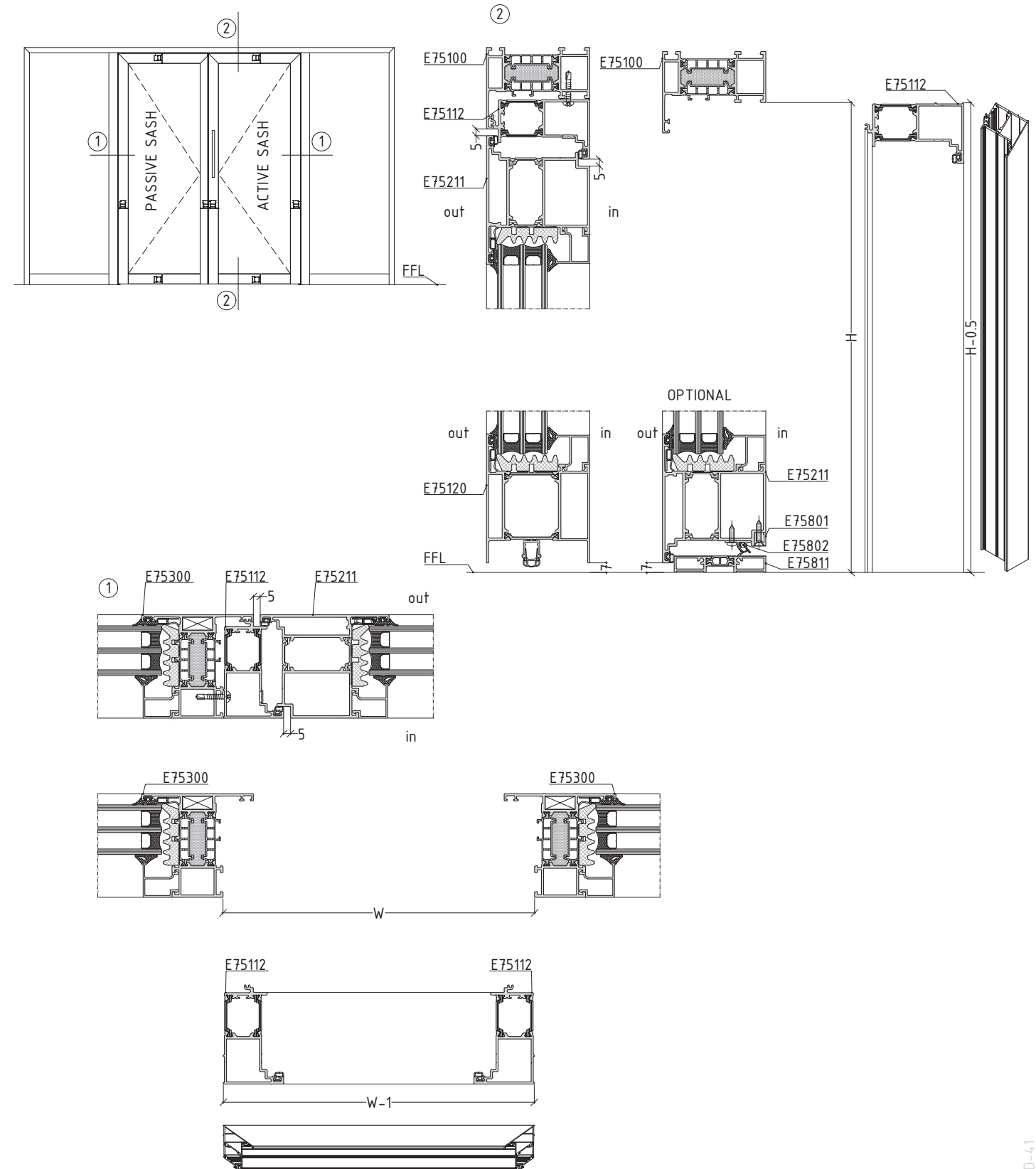

not to scale

M75D-41

flat door system with thermal break

E75FD

inward opening - double sash door  
combination - E75 flat door + E75

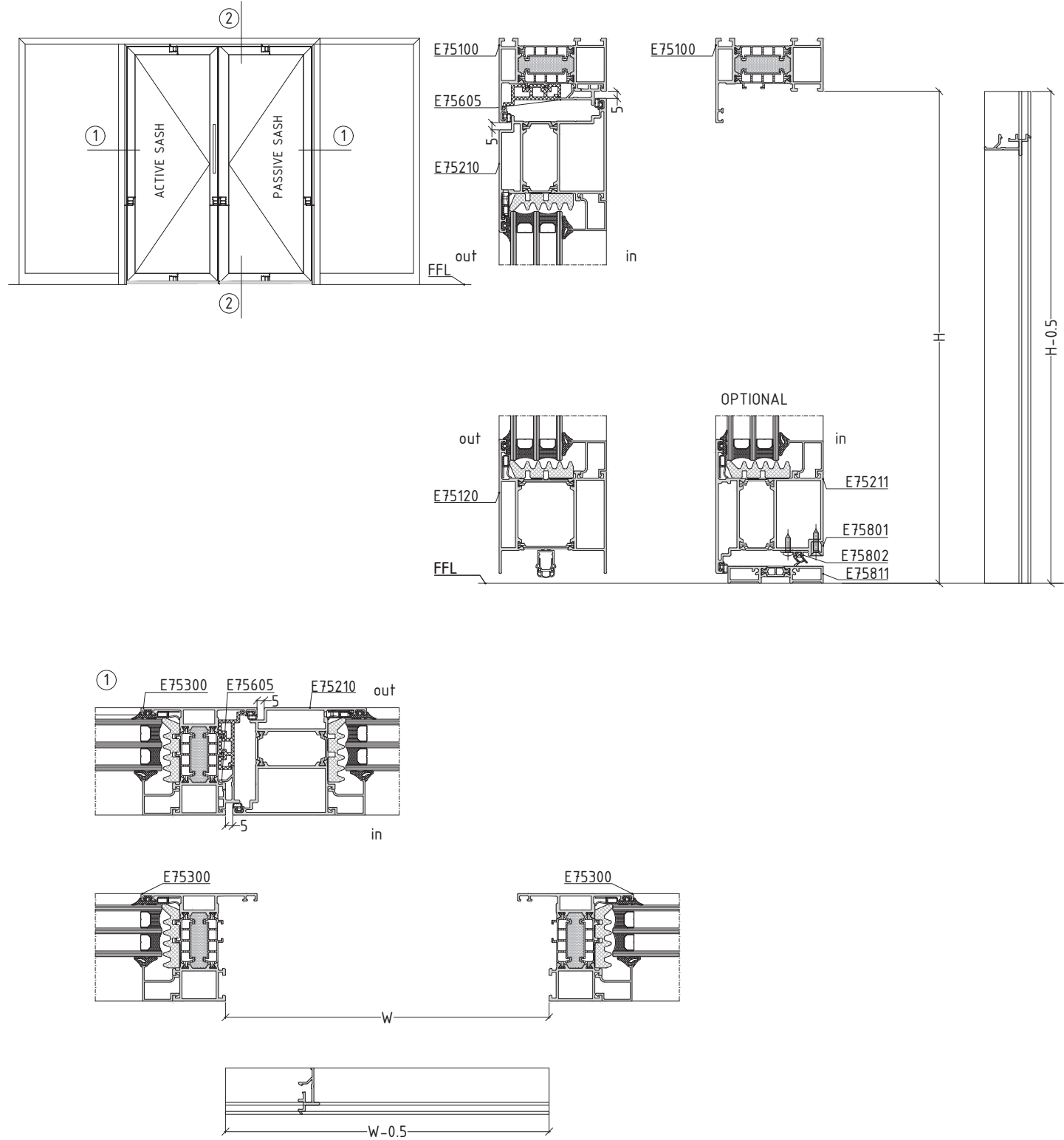

not to scale

M75D-42

flat door system with thermal break

E75FD

inward opening door combination  
E75 flat door + E75

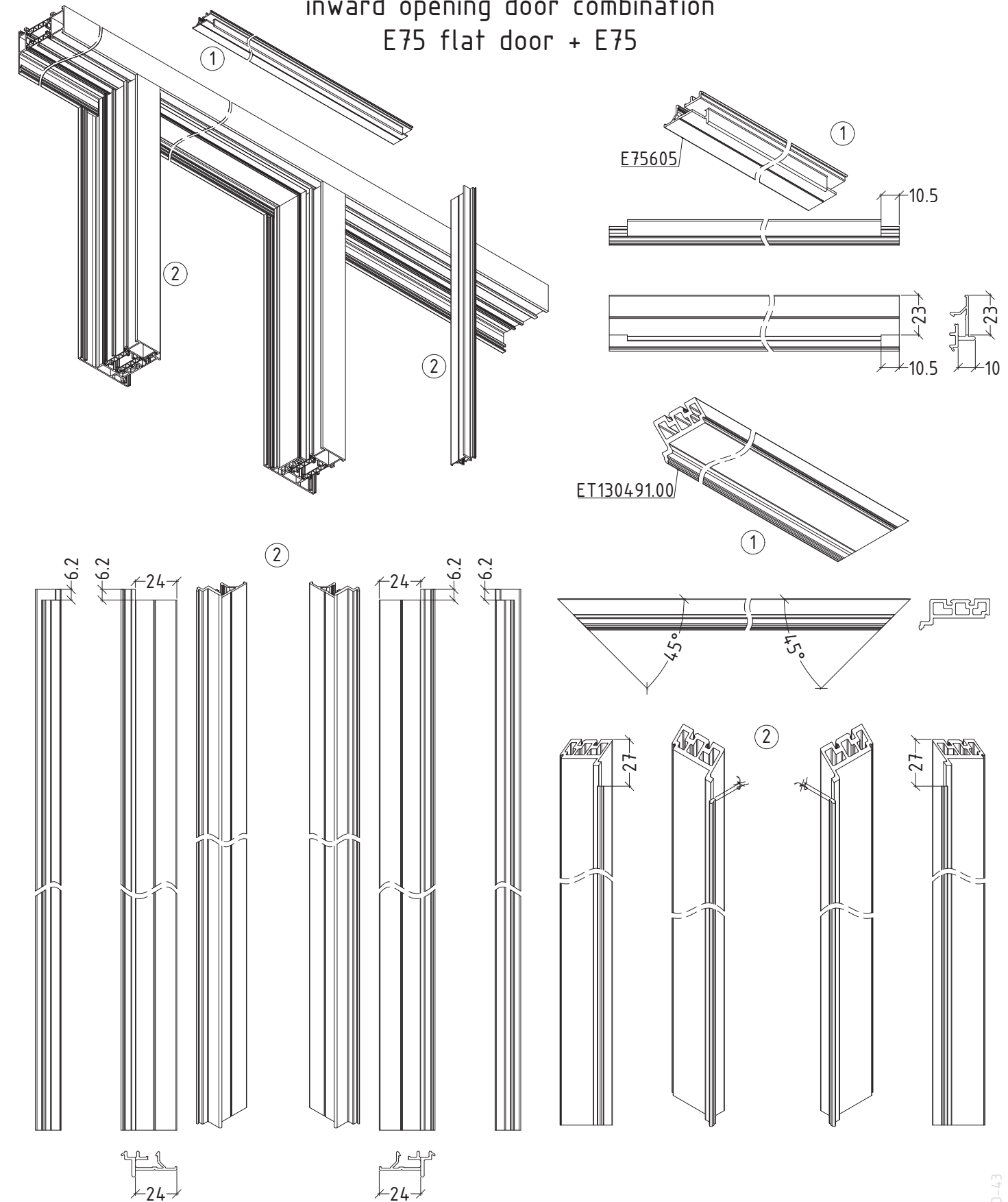

not to scale

M75D-43

machining required on E75211 for lock

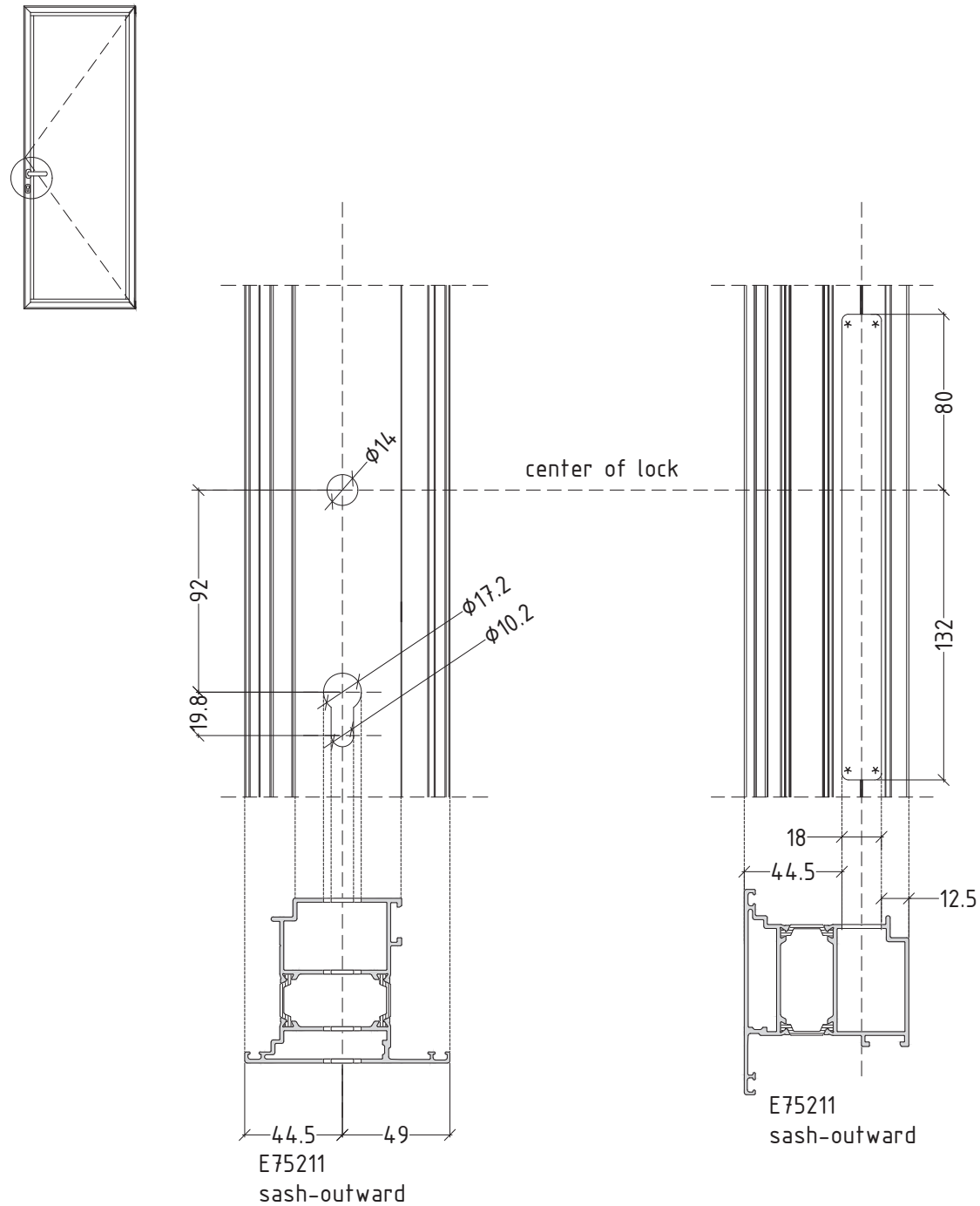

\* The dimensions refer to anodized and mill-finished profiles!

For powder coated profiles, the thickness of the coating must be taken into account!  
not to scale

\*  
R=3mm

M75D-44

machining required on E75111 & E75211 for lock

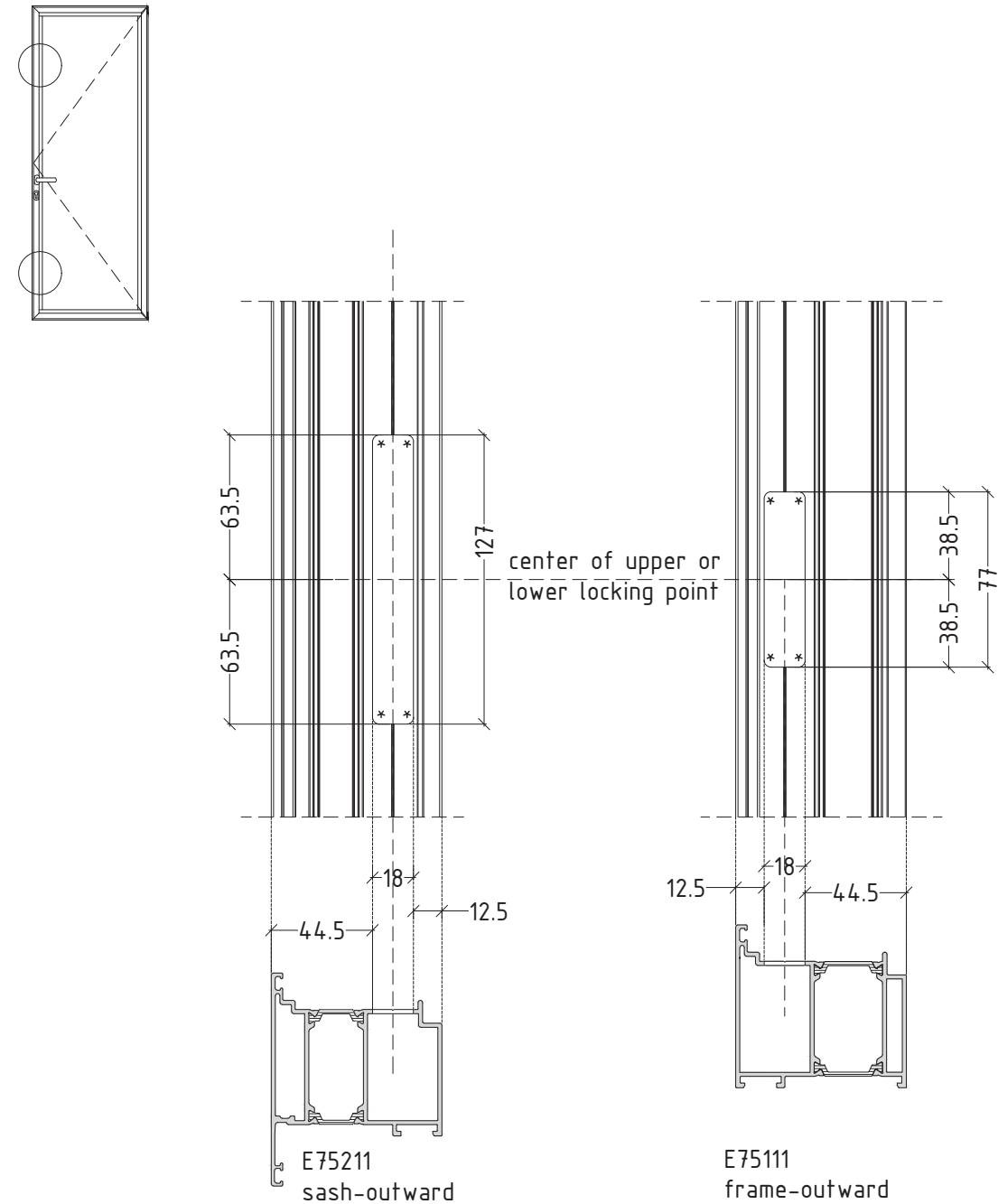

\* The dimensions refer to anodized and mill-finished profiles!

For powder coated profiles, the thickness of the coating must be taken into account!  
not to scale

\*  
R=3mm

M75D-45

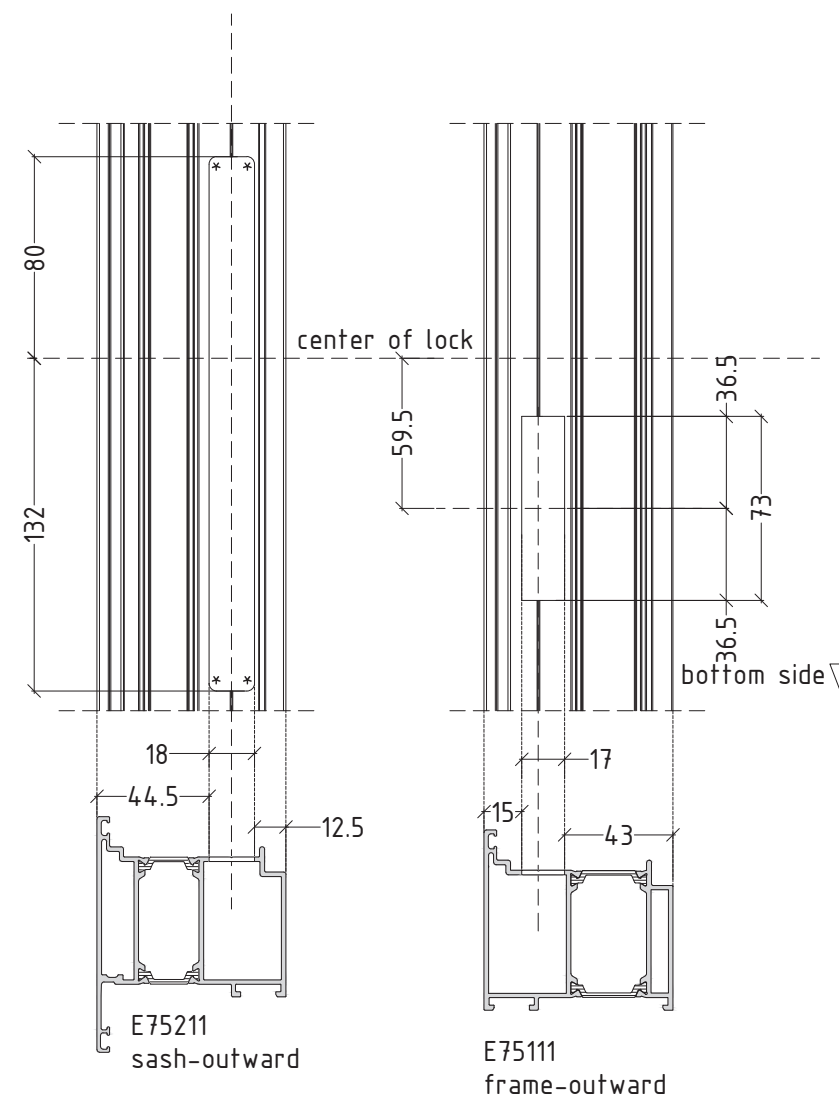
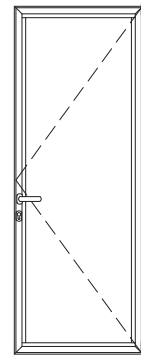

\* The dimensions refer to anodized and mill-finished profiles!

For powder coated profiles, the thickness of the coating must be taken into account!  
not to scale

\*  
R=3mm

M75D-46

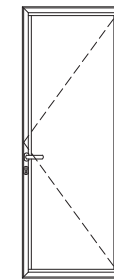

machining required on E75111 & E75211 for lock

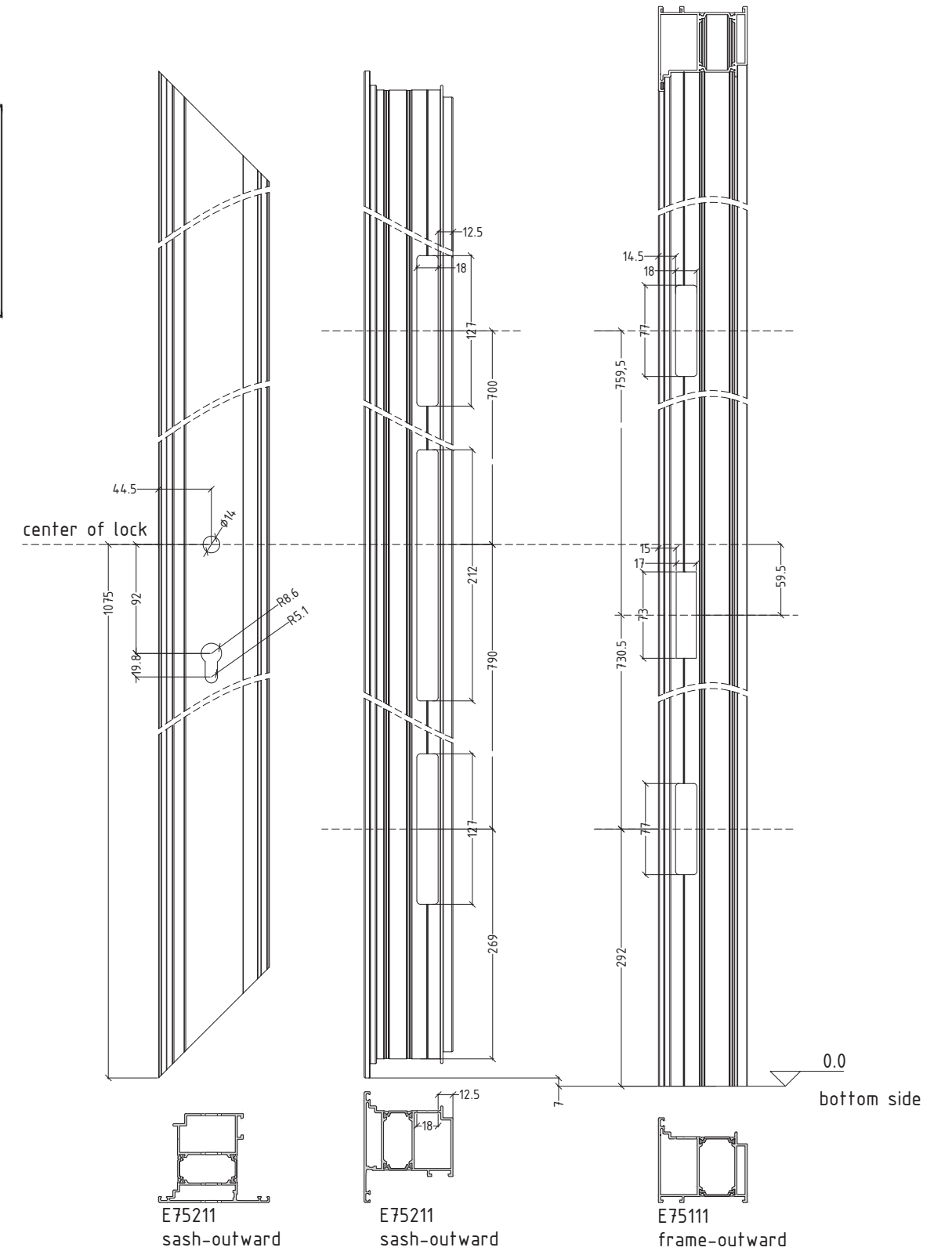

\* The dimensions refer to anodized and mill-finished profiles!

For powder coated profiles, the thickness of the coating must be taken into account!

not to scale

M75D-47

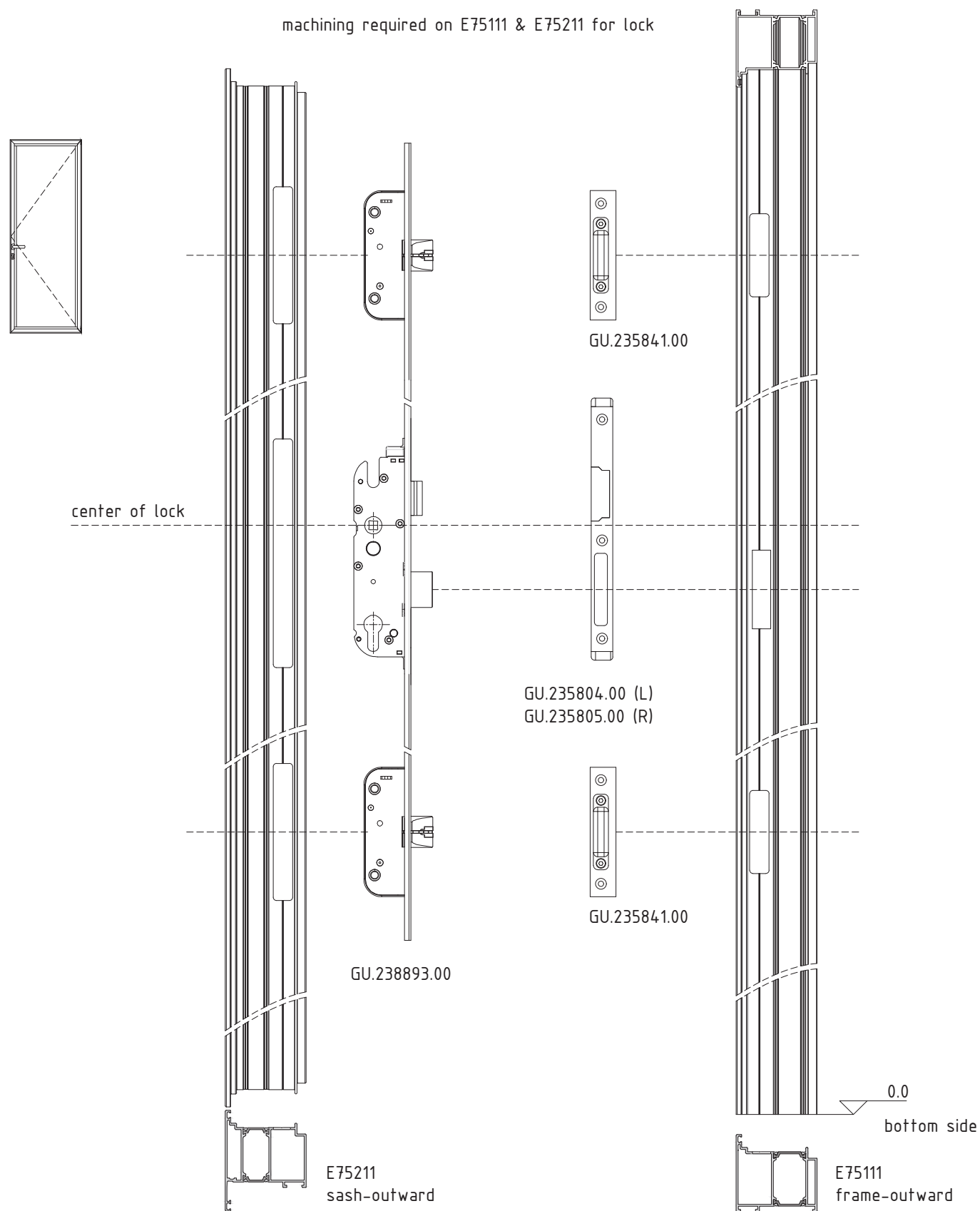

\* The dimensions refer to anodized and mill-finished profiles!

For powder coated profiles, the thickness of the coating must be taken into account!

not to scale

M75D-48

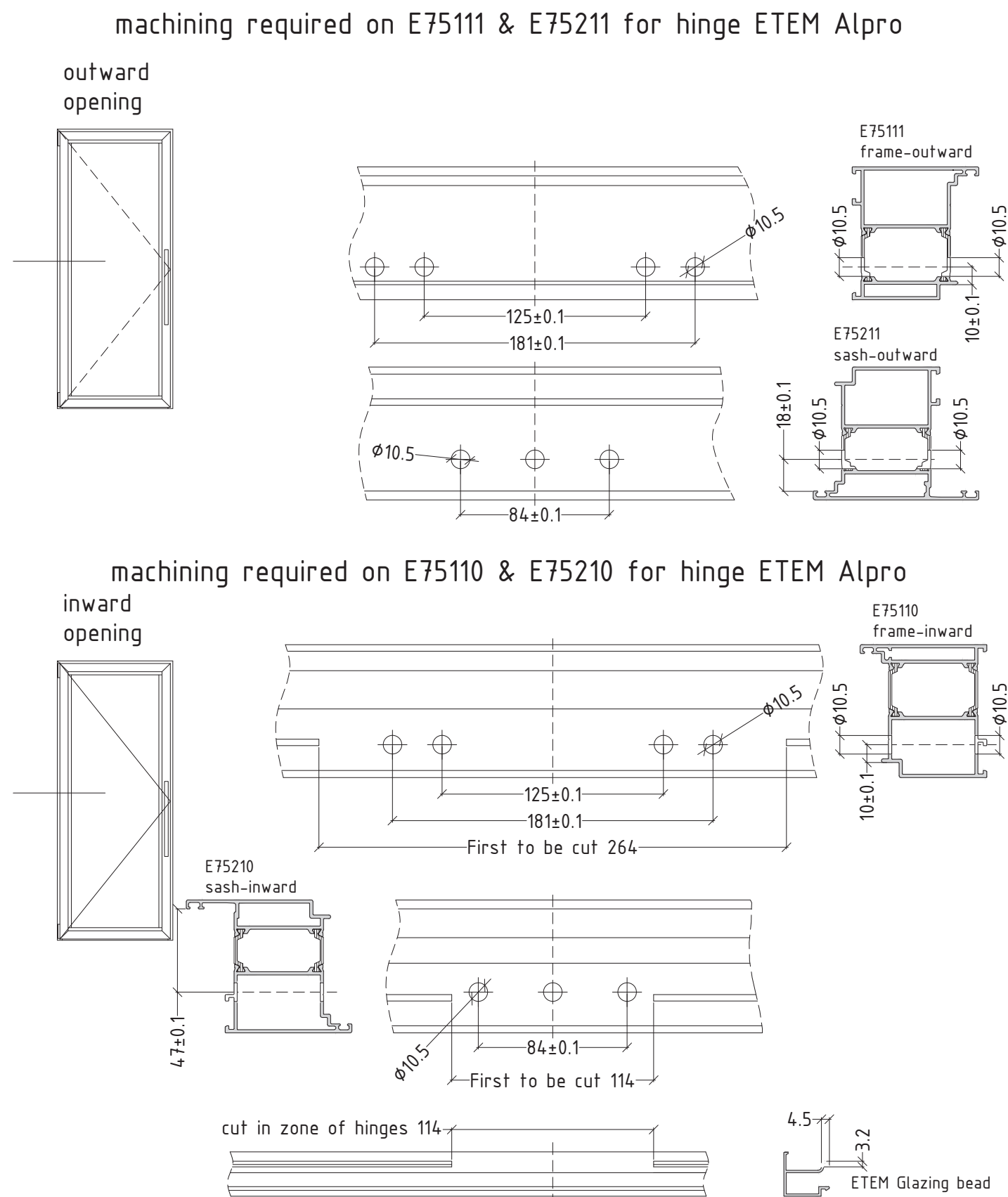

\* The dimensions refer to anodized and mill-finished profiles!

For powder coated profiles, the thickness of the coating must be taken into account!

not to scale

M75D-49

sequence of assembly and adjustment for hinge ETEM Alpro

outward opening

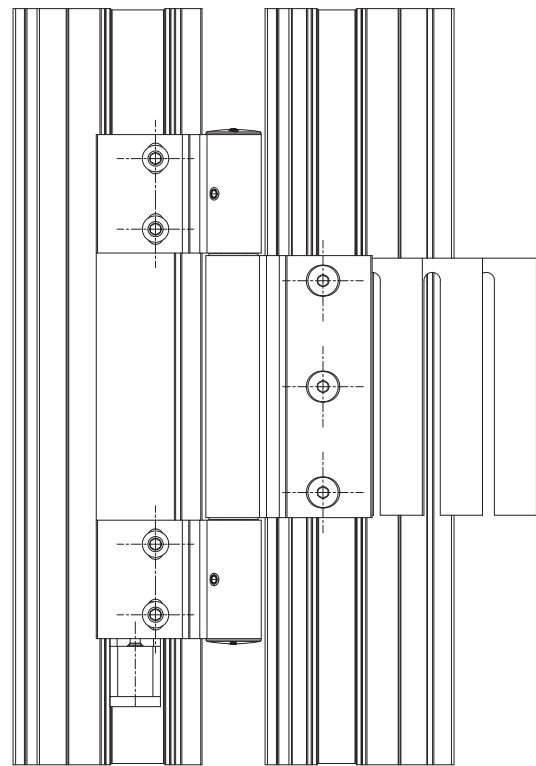
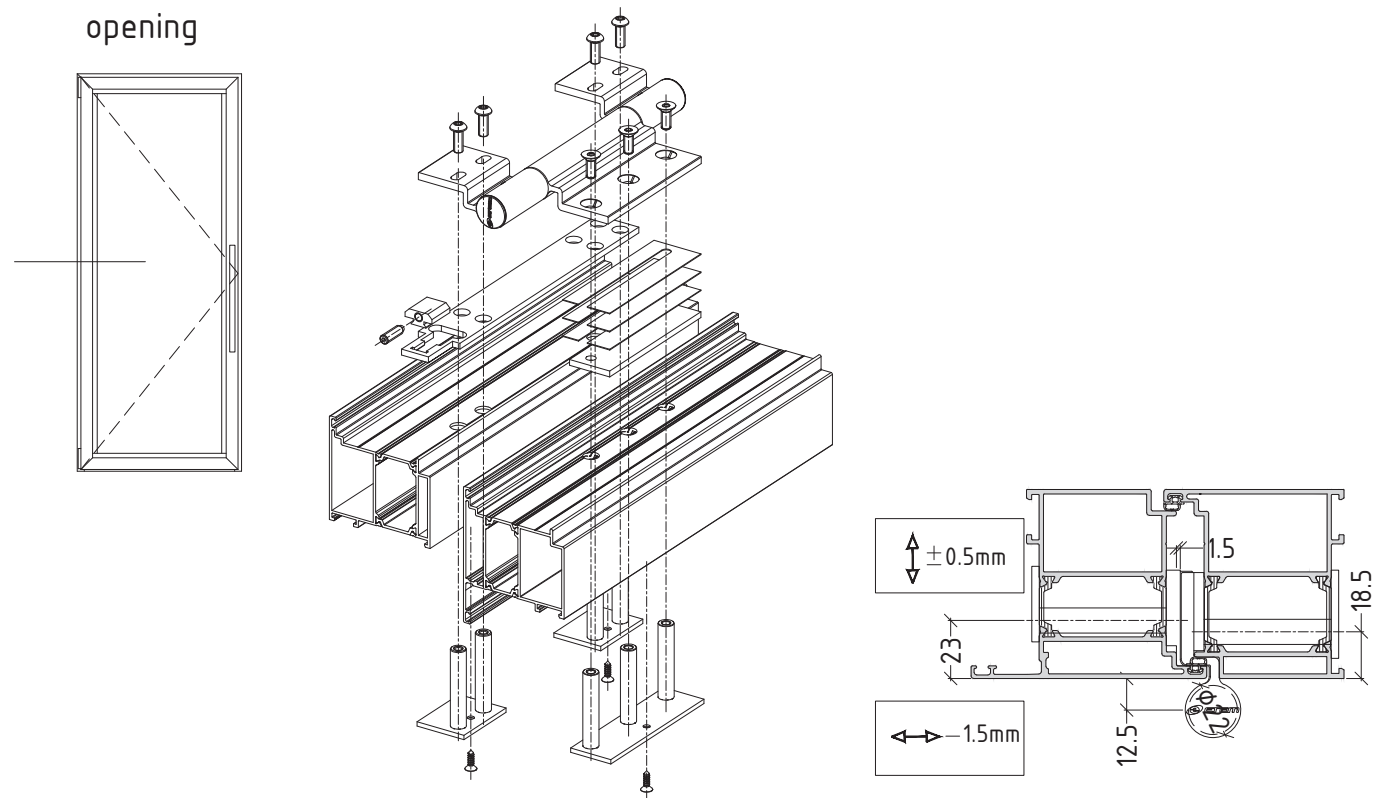

not to scale

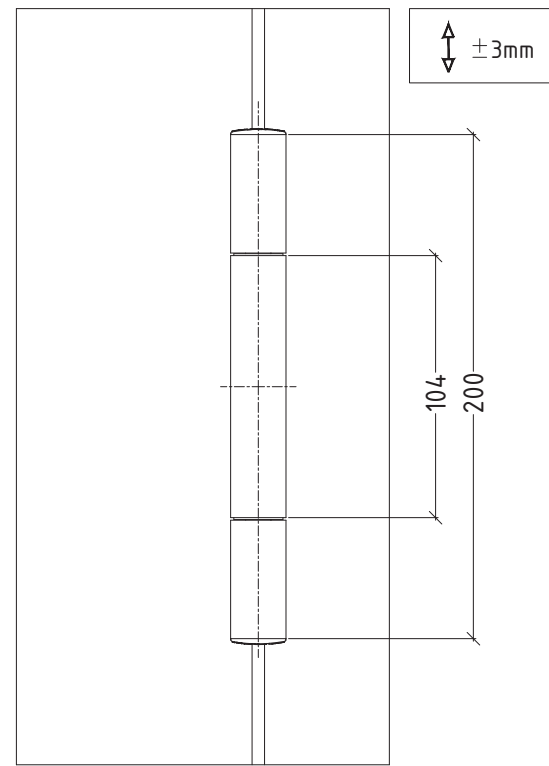

M75D-50

machining required on frame E75111 and sash E75211 for hidden hinge Simonswerk TECTUS

outward opening

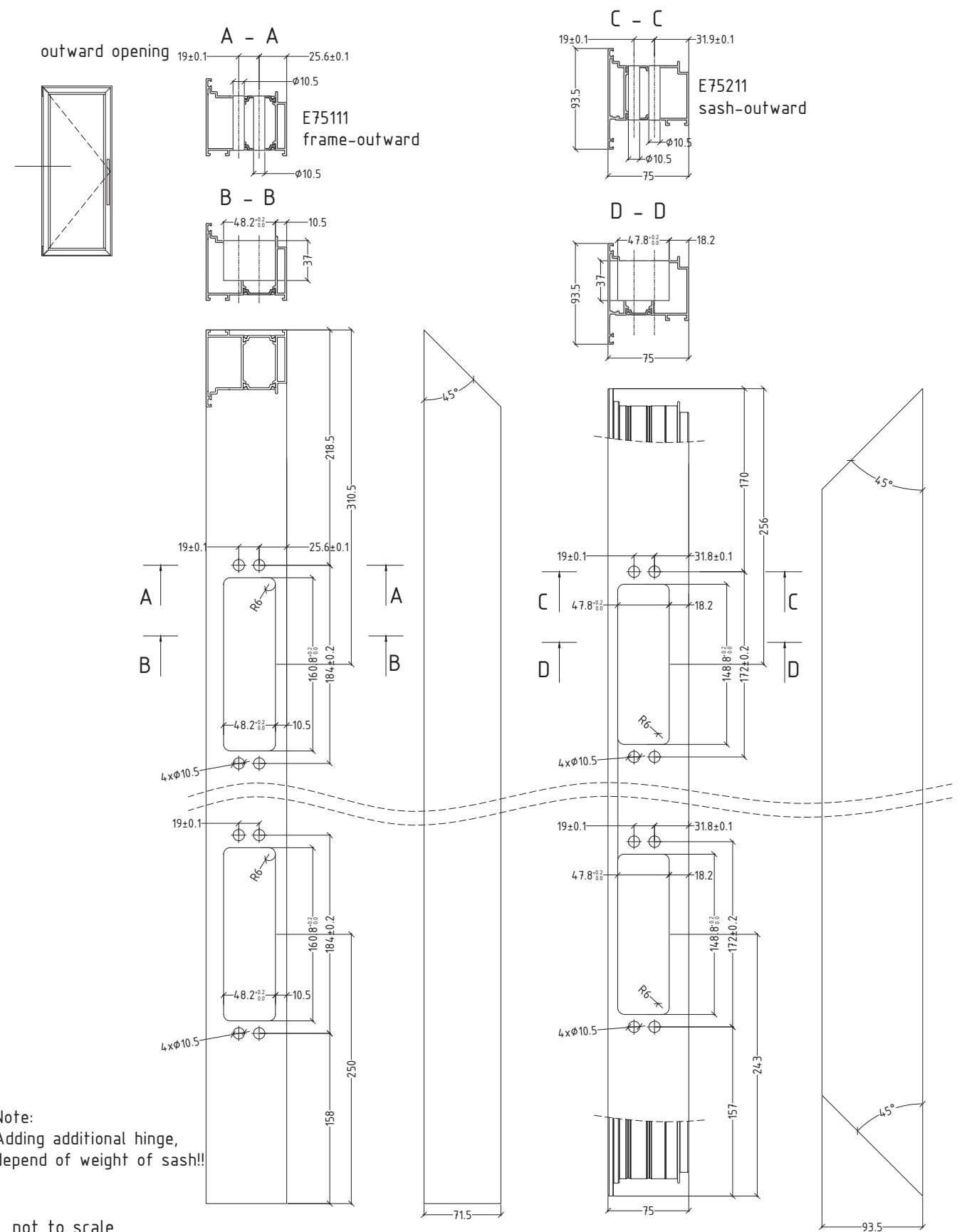

Note:  
Adding additional hinge,  
depend of weight of sash!!

not to scale

M75D-51

machining required on frame E75110 and sash E75210 for hidden hinge Simonswerk TECTUS

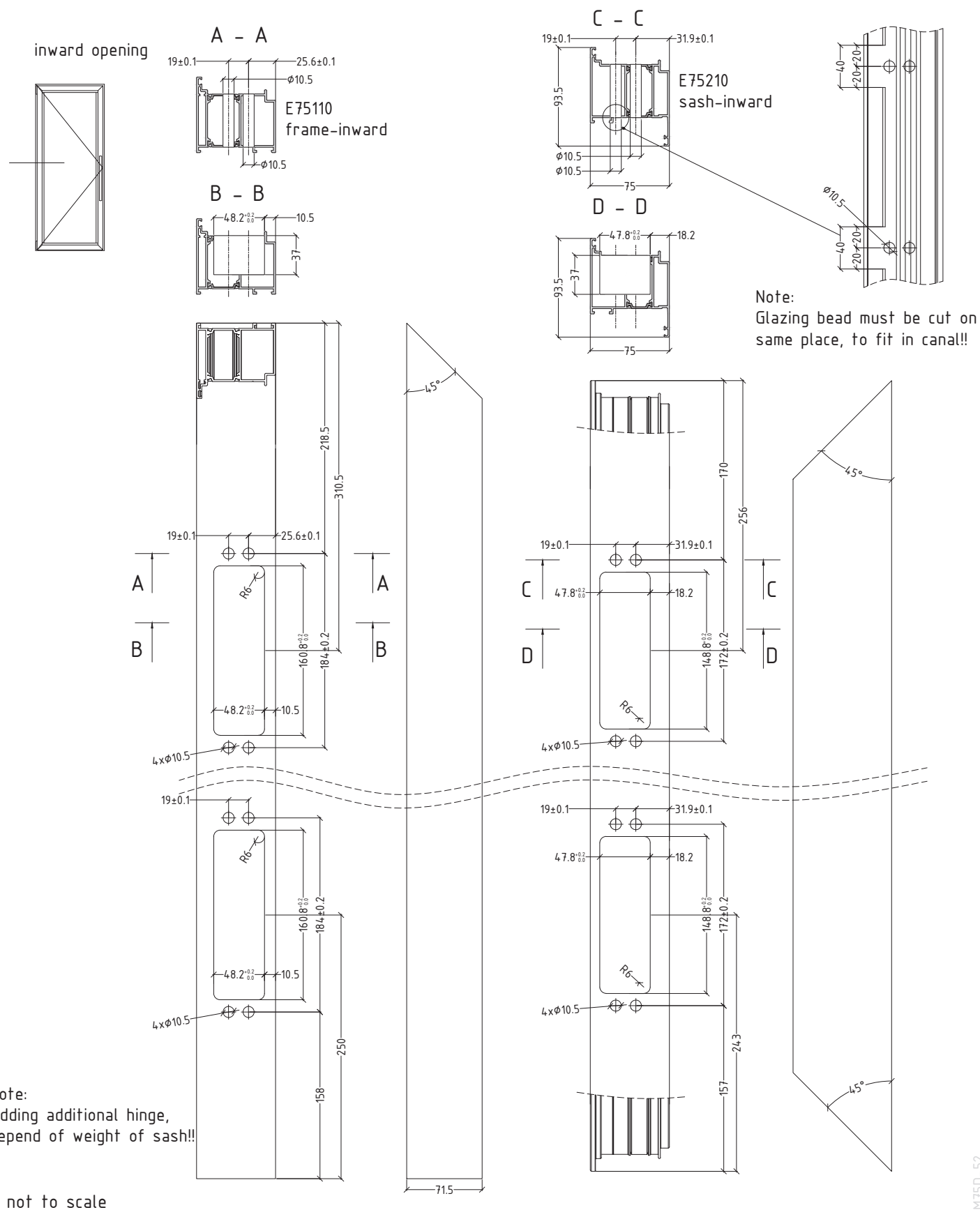

TYPE 1: Mounting door sealing system for E75FP double-sash with four side E75211 with brush holder

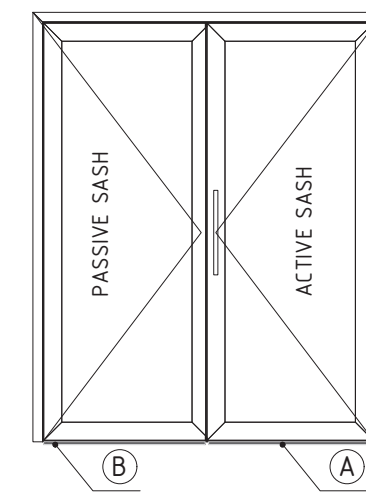

Ⓐ Sealing system for active sash. Install cap A<sub>1</sub>

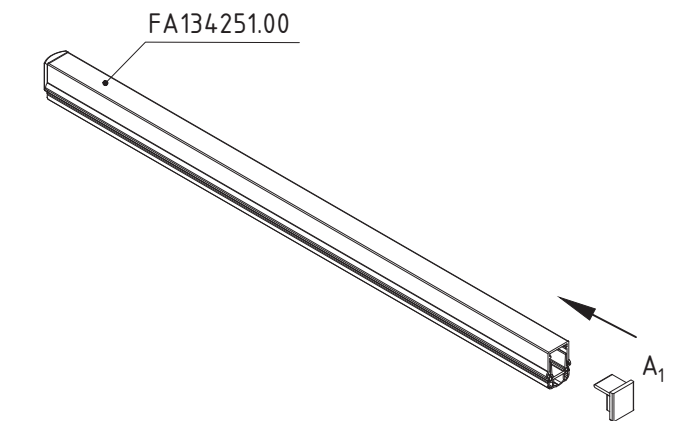

Ⓑ Sealing system for passive sash. Install cap B<sub>1</sub>

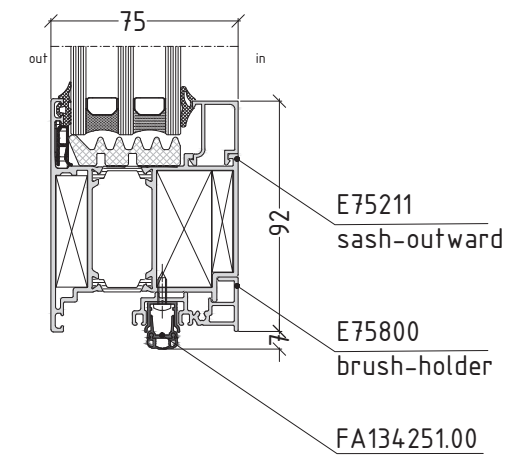
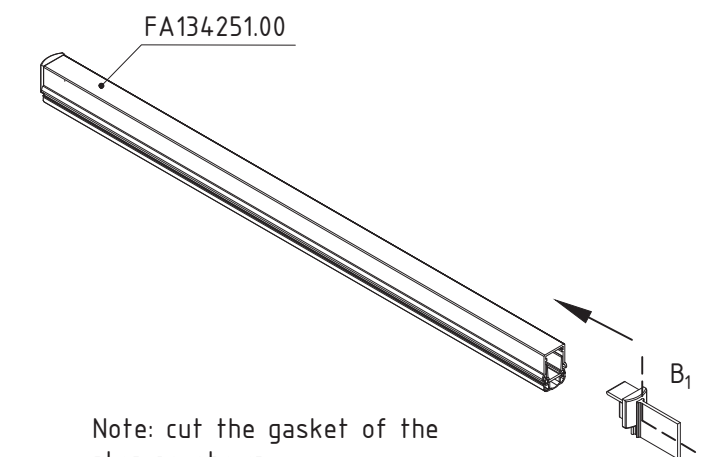

Caps in the package for door sealing system

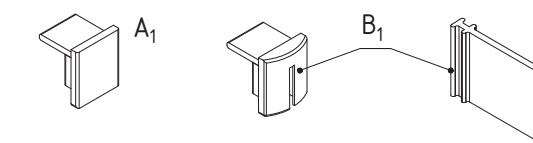

not to scale

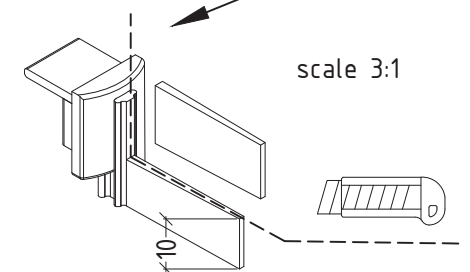

flat door system with thermal break

E75FD

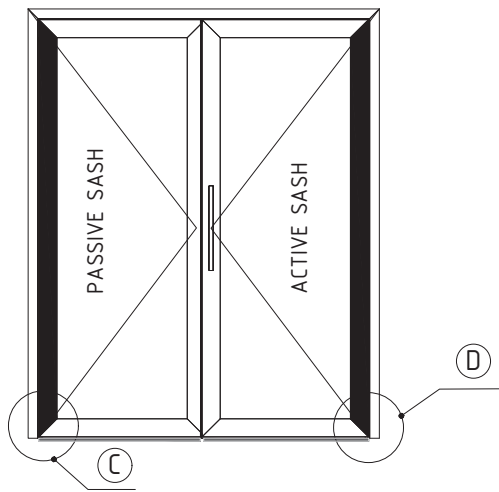

Note:  
Install the caps on both wings but only on the sash - frame side. In the middle the caps are different.

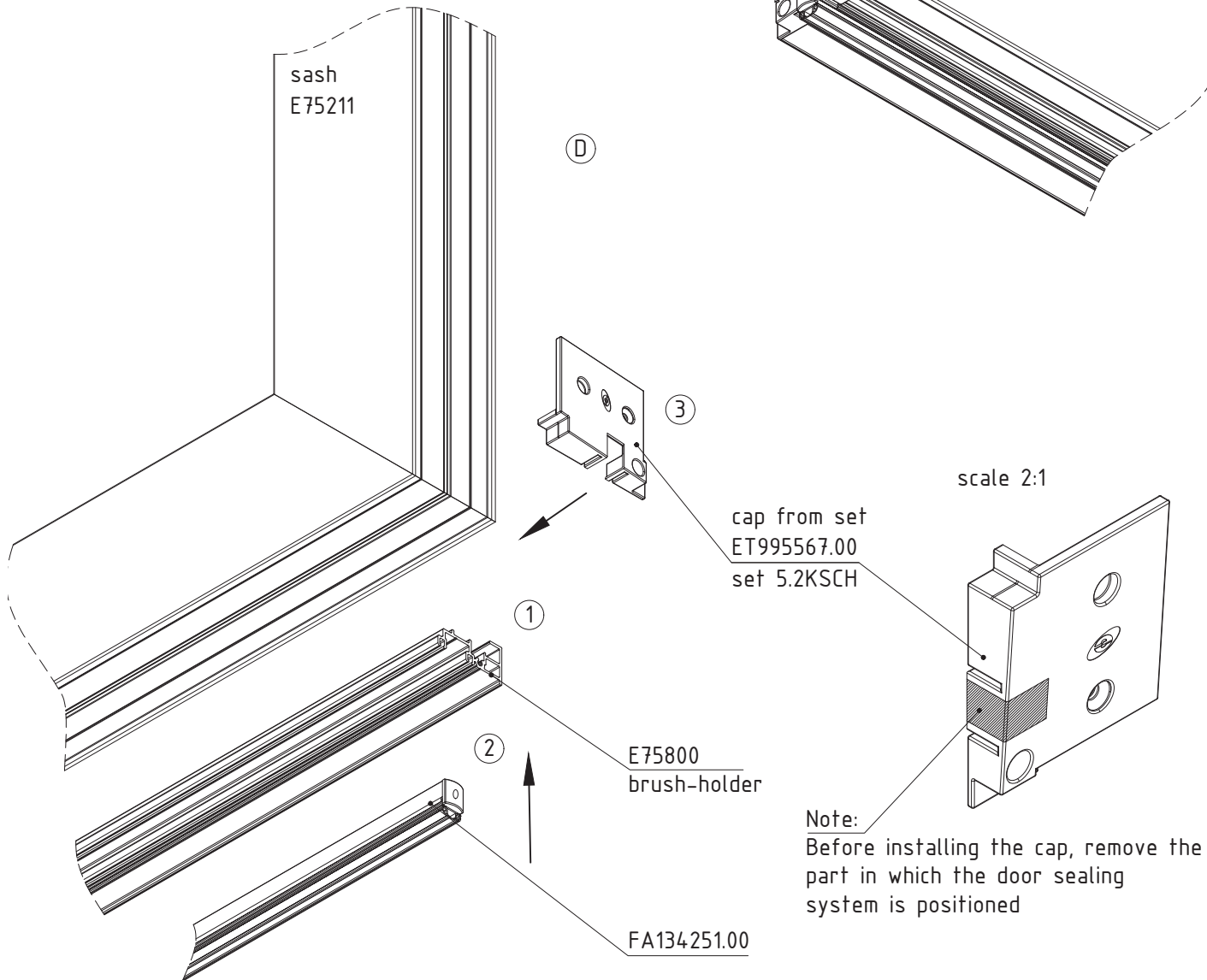
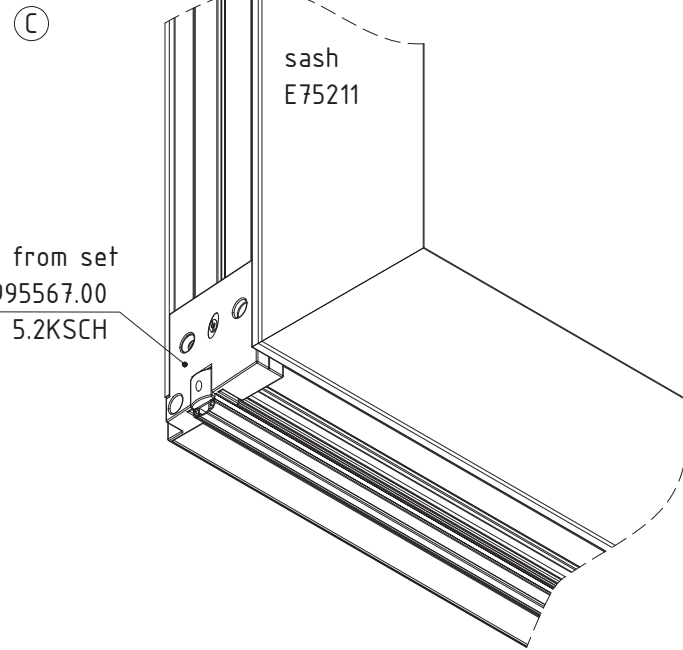

not to scale

M75D-54

flat door system with thermal break

E75FD

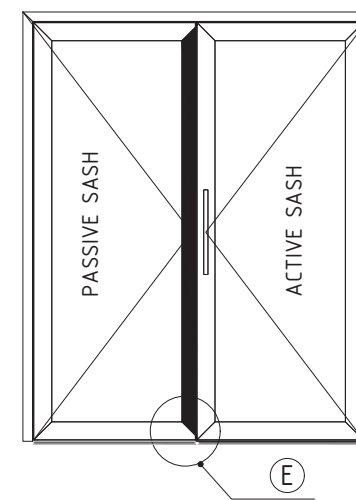

Note:  
Install the cap on the vertical profile of the passive sash from the handle side

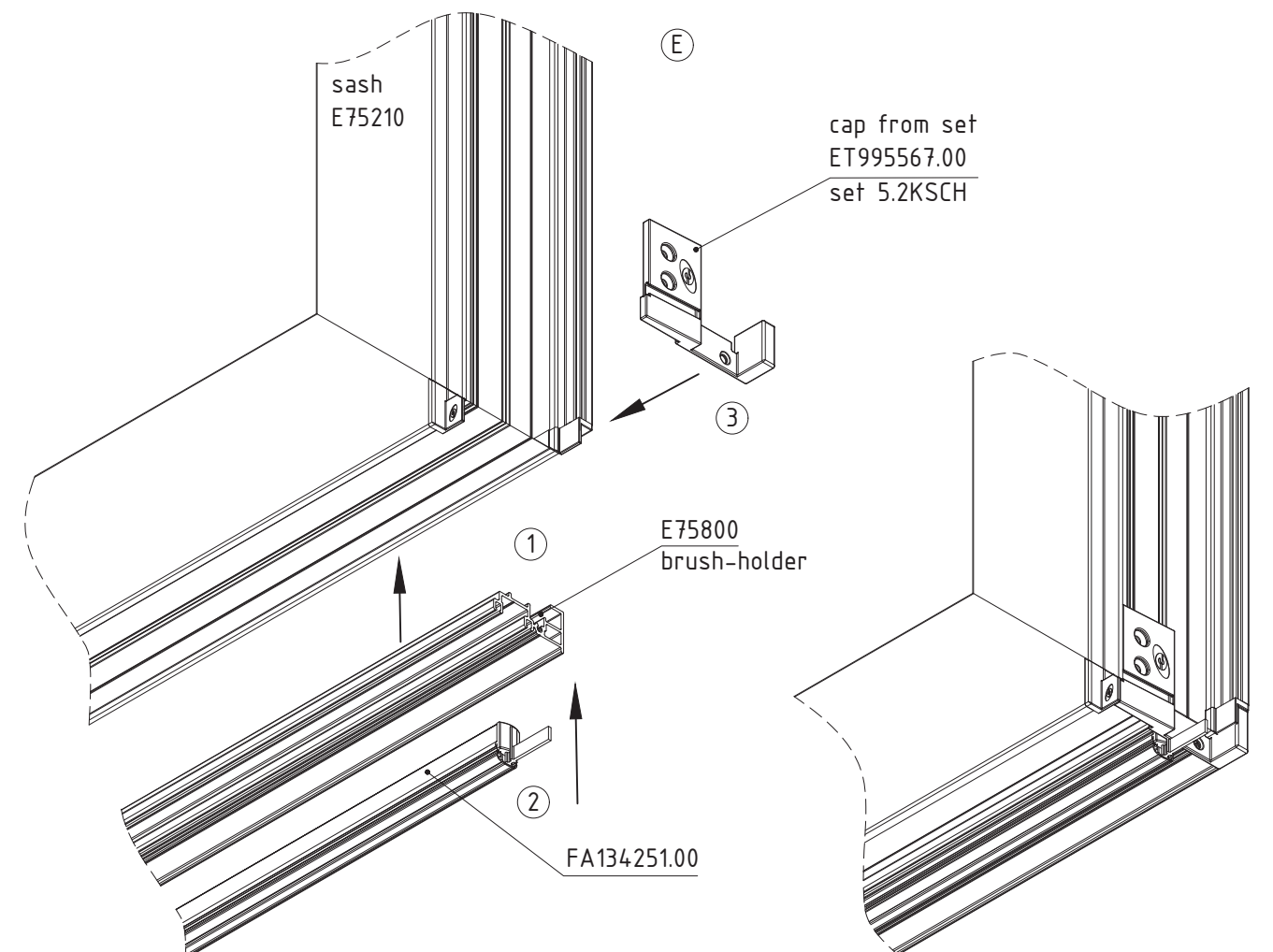
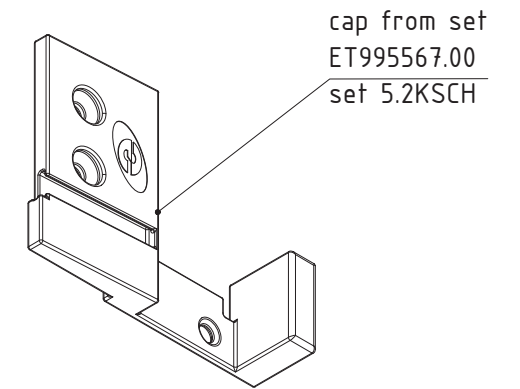

not to scale

M75D-55



TYPE 2: Mounting door sealing system for E75 double-sash flat door with kick plate

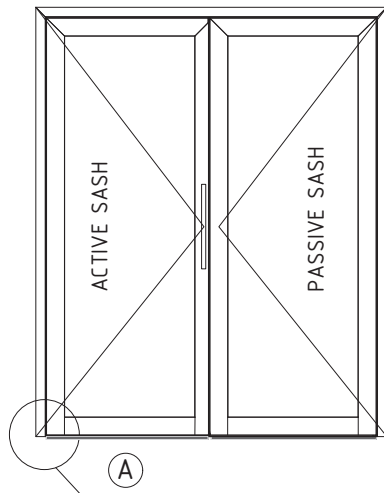

Sealing system for active sash.  
Install cap A<sub>1</sub>

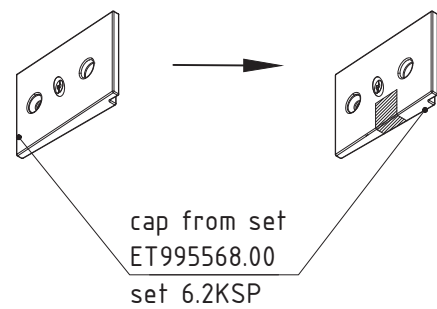
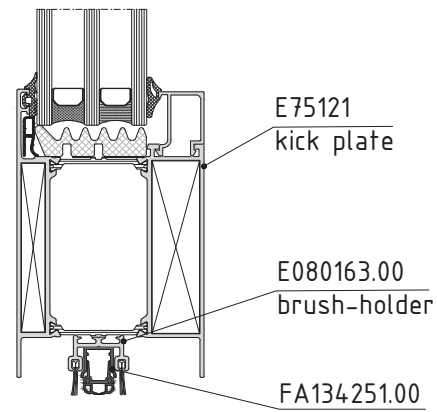
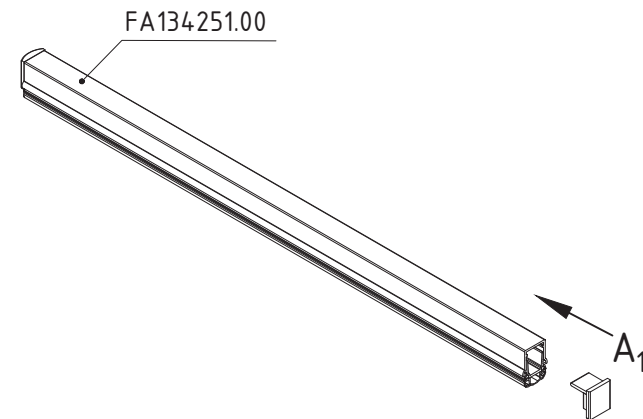

Note:  
Before installing the cap, remove the part in which the door sealing system is positioned

not to scale

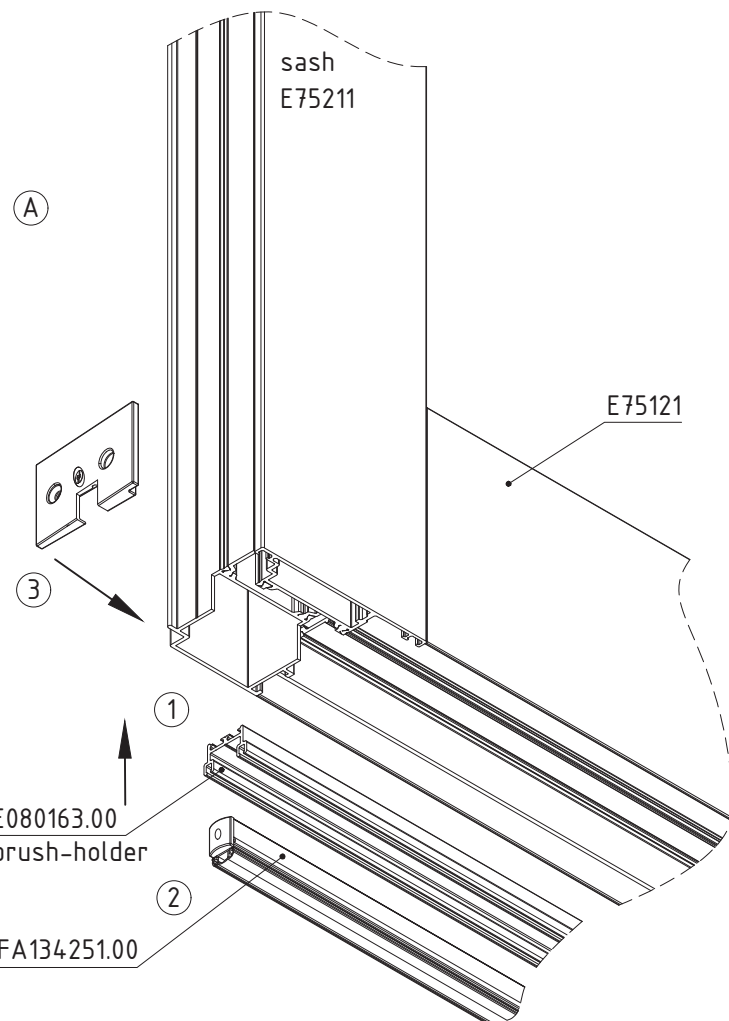

M75D-56

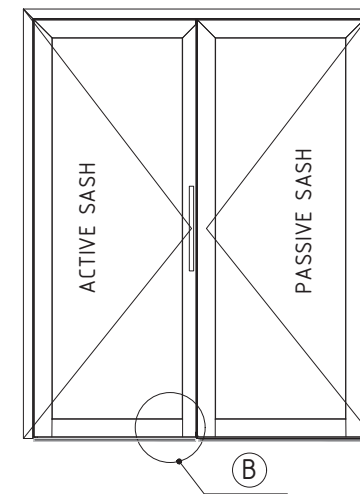

Note:  
Install the cap on the vertical profile of the active wing on the handle side

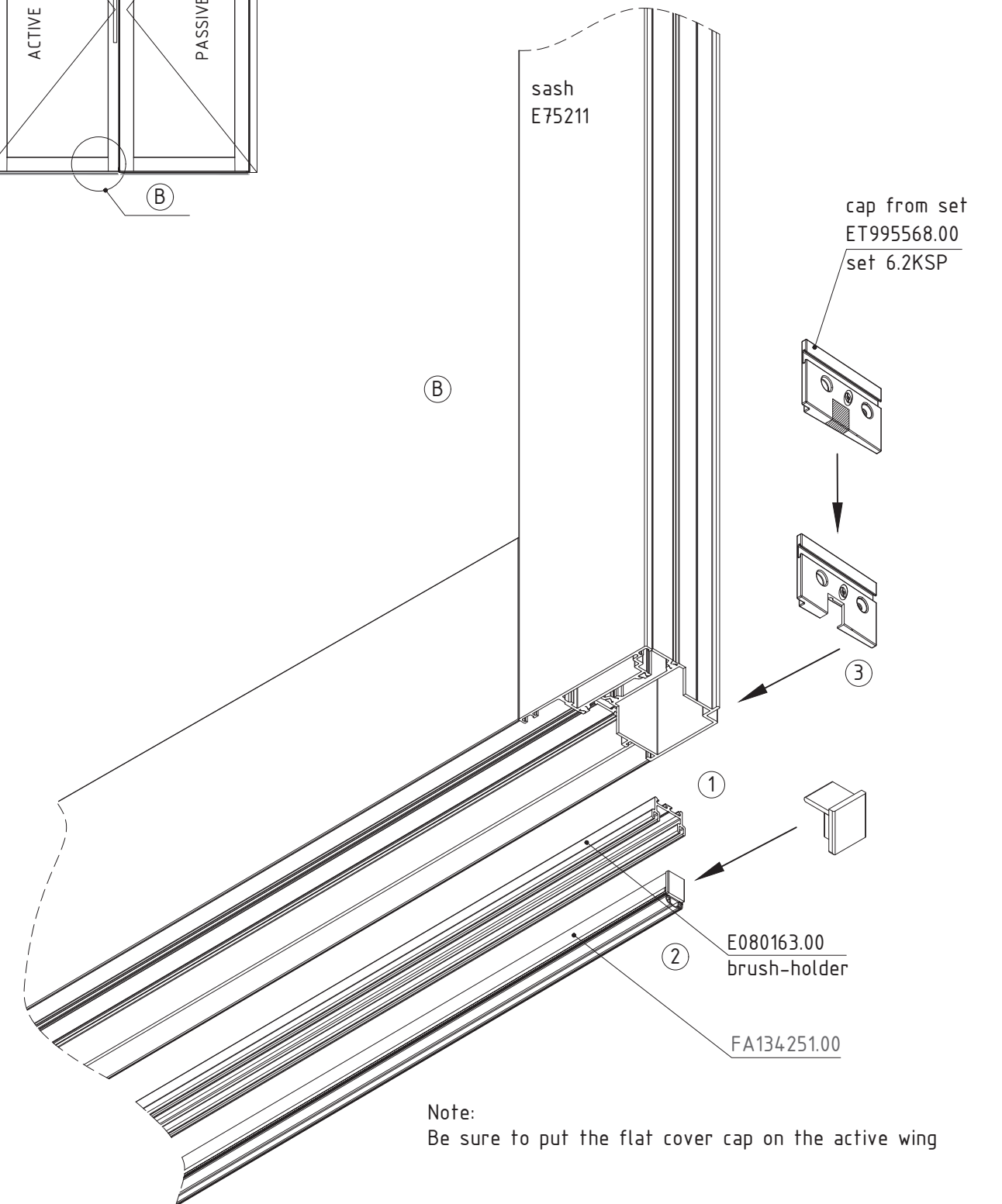

Note:  
Be sure to put the flat cover cap on the active wing

not to scale

M75D-57

Machining for door sealing system for E75 double-sash flat door with kick plate

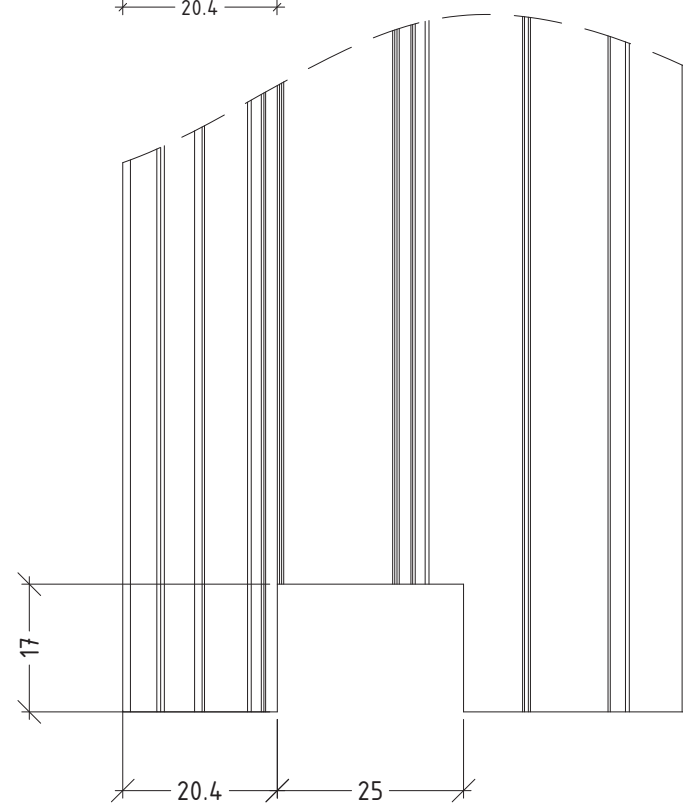
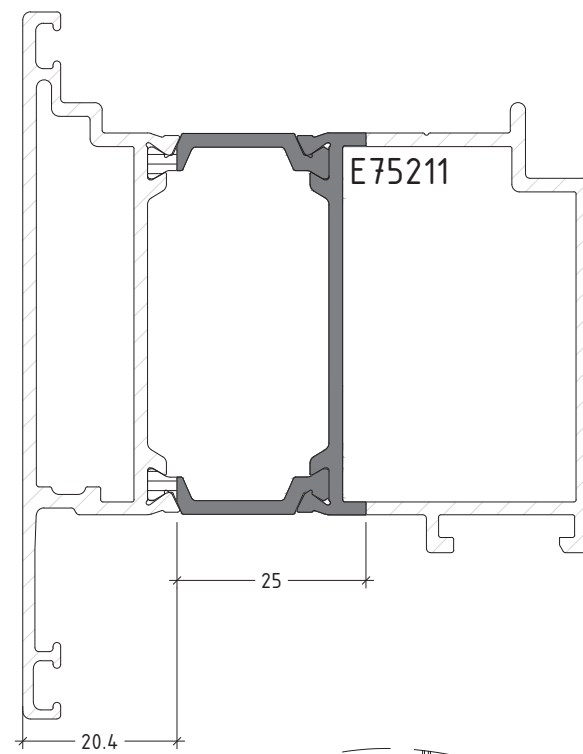
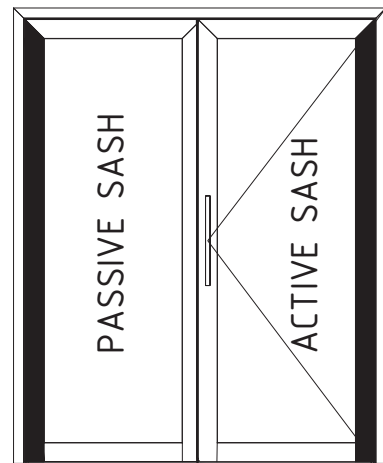

not to scale

M75D-58

Machining for door sealing system for E75 double-sash flat door with kick plate

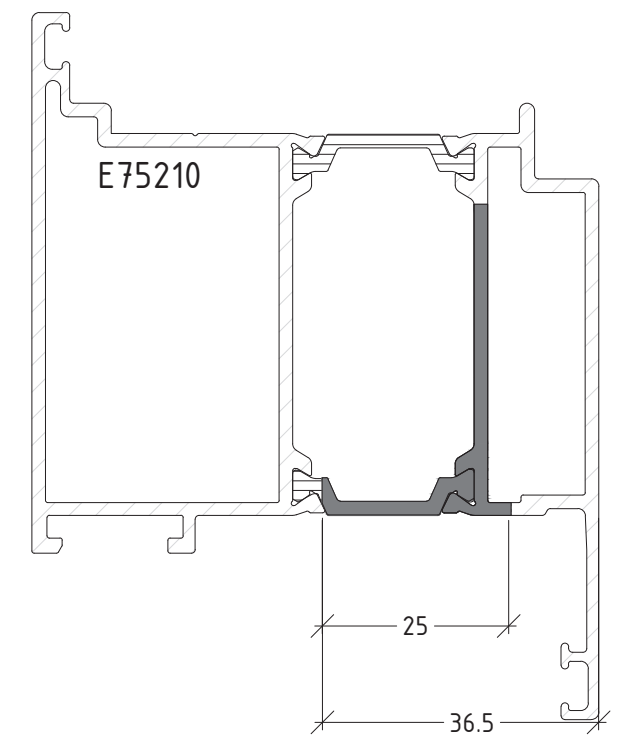
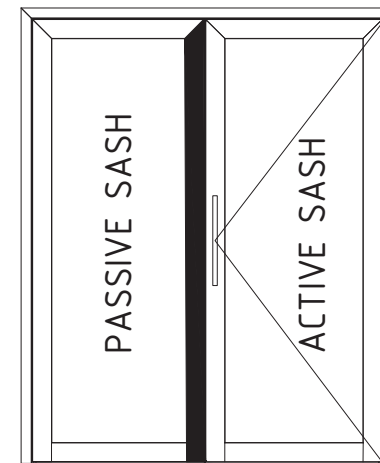

Note:  
Cutting the other wall of the aluminium profile is not obligatory.

scale: 1:2

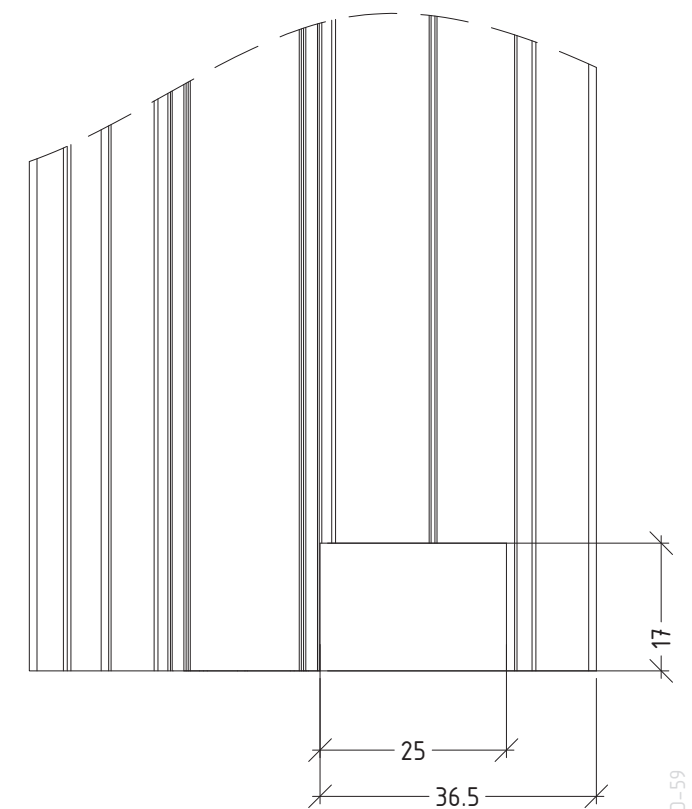
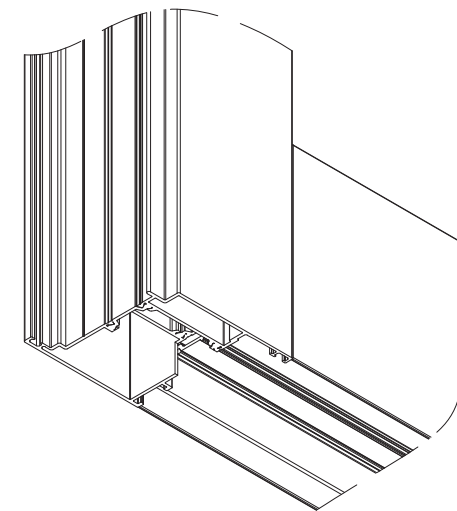

not to scale

M75D-59

TYPE 3: Mounting door sealing system for E75 single-sash flat door with kick plate

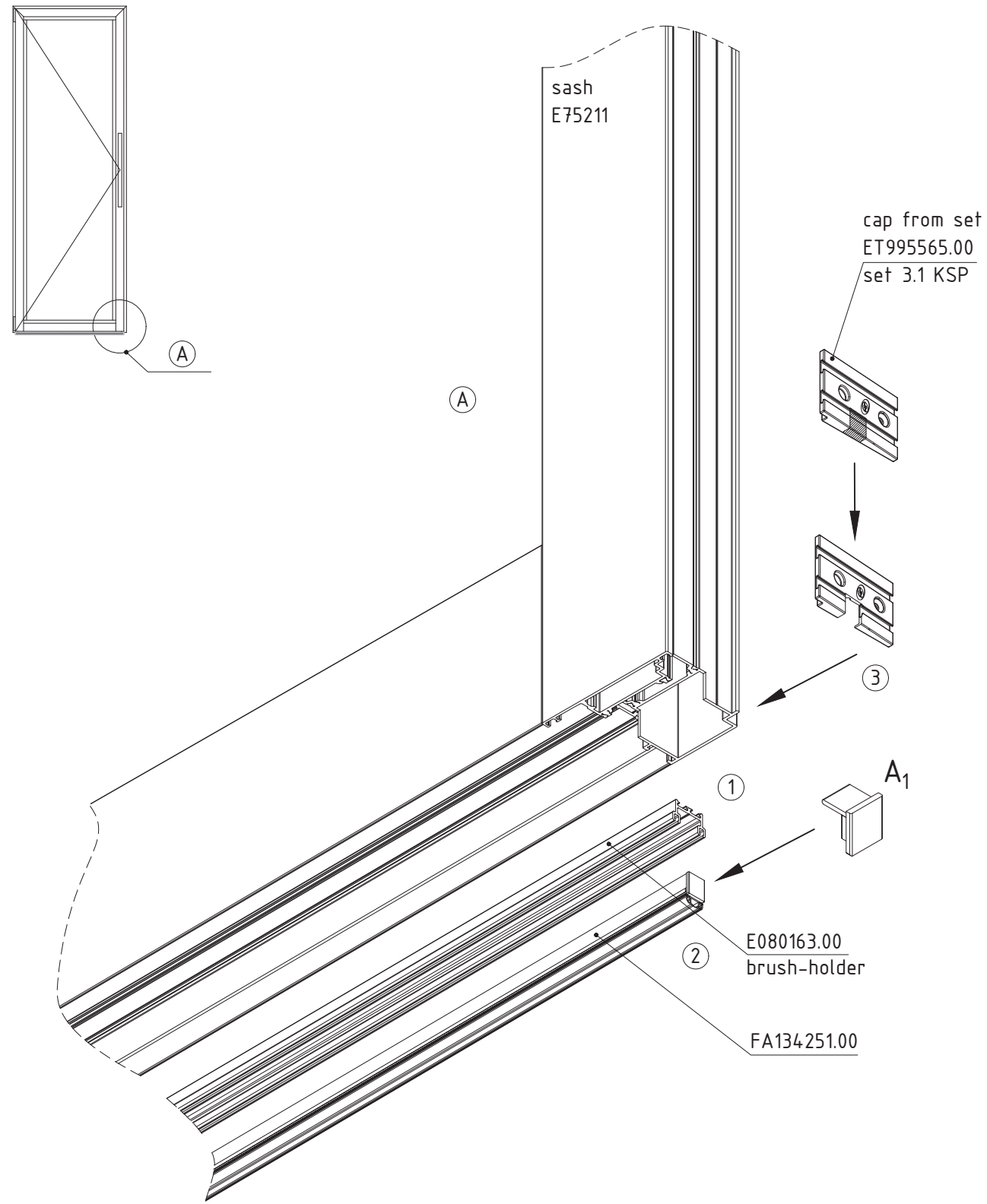

not to scale

M75D-60

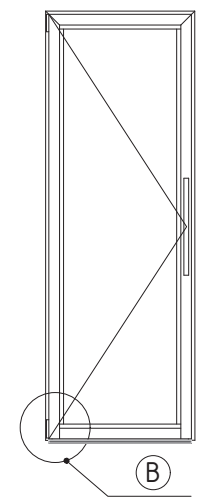

Sealing system for active sash. Install cap A<sub>1</sub>

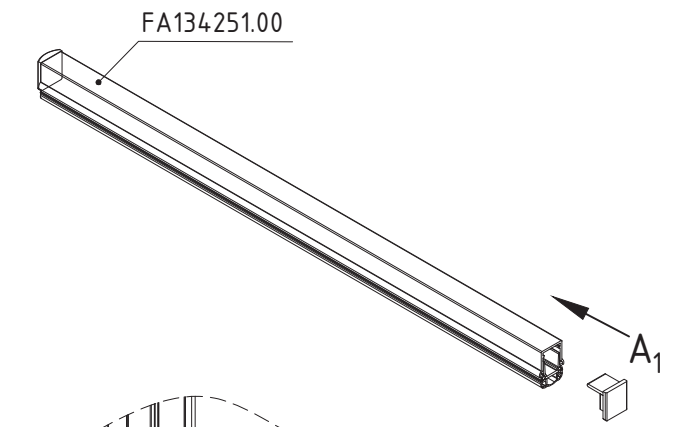

Note: Before installing the cap, remove the part in which the door sealing system is positioned

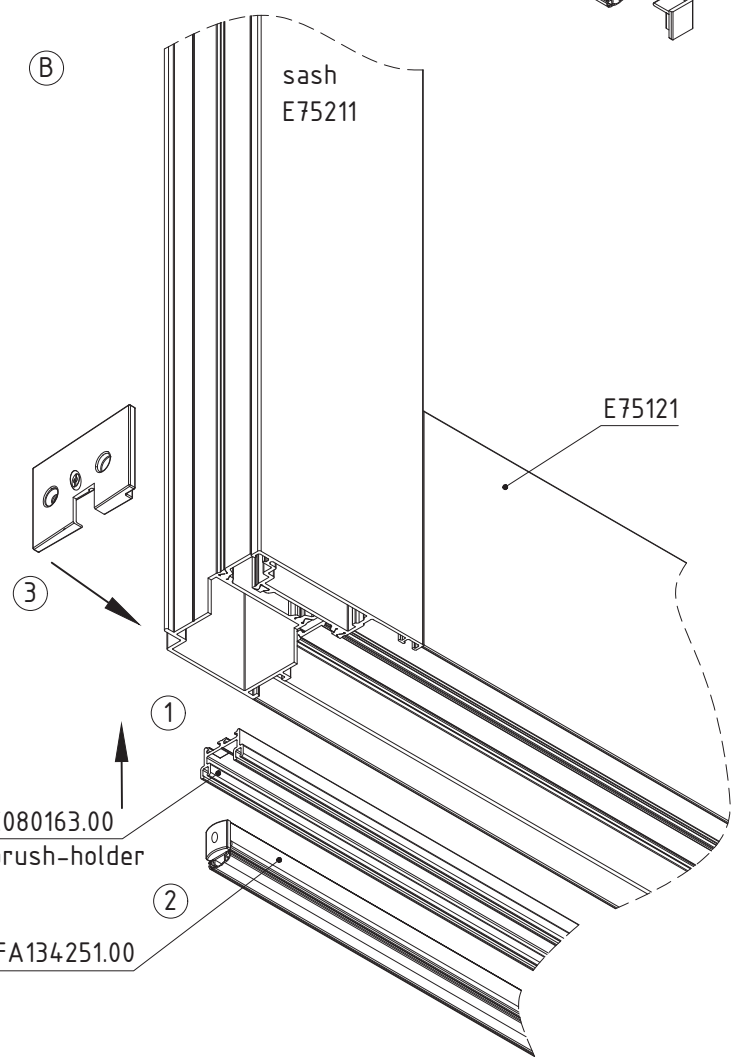
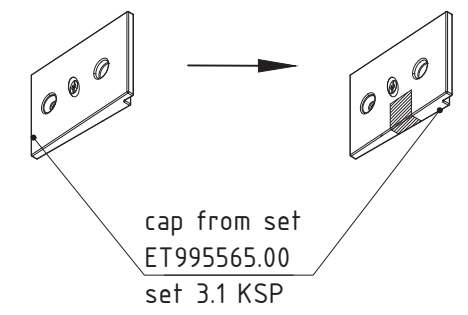

not to scale

M75D-61

TYPE 4: Mounting door sealing system for E75FP single-sash four side E45211 with brush holder

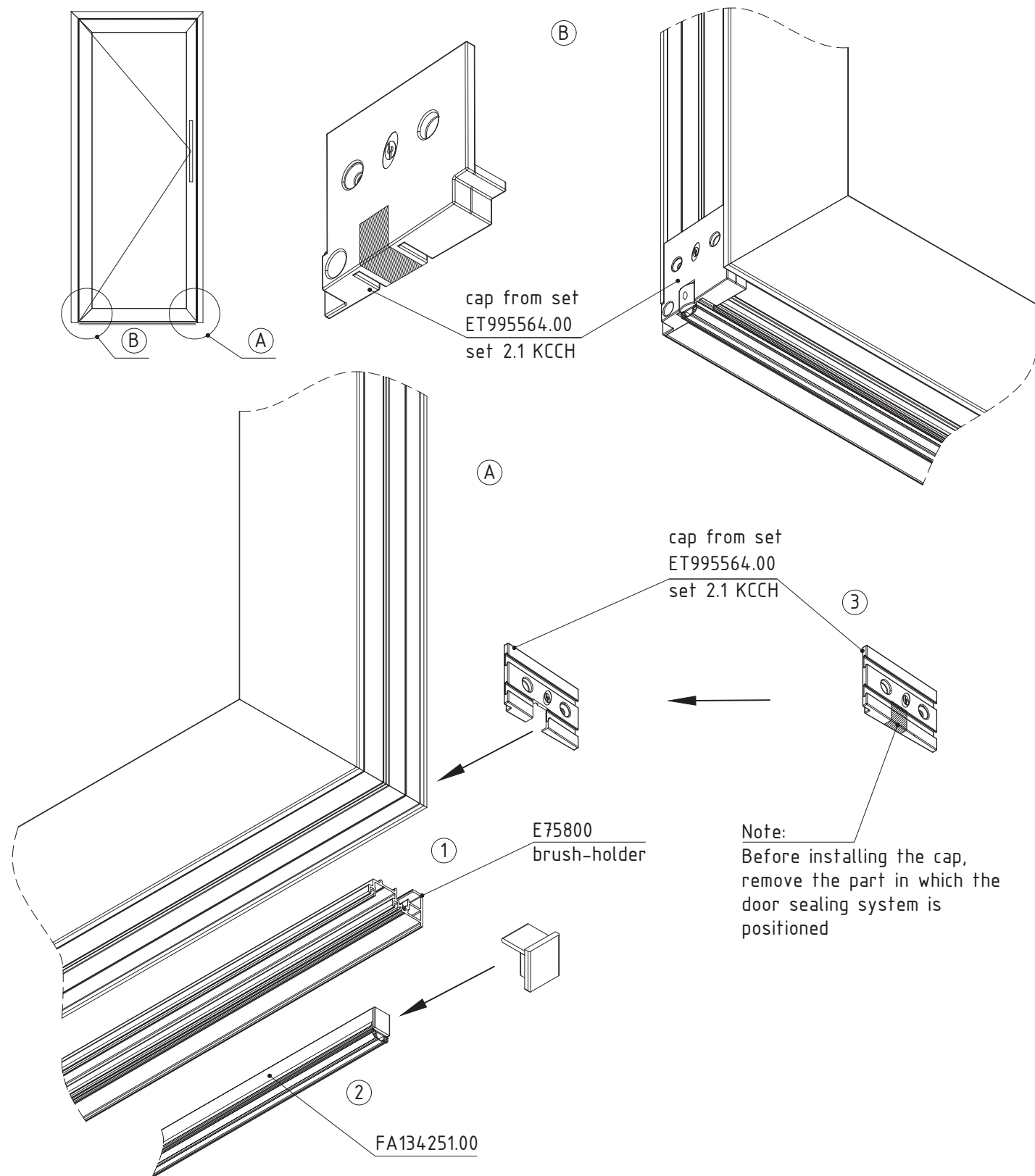

not to scale

M75D-62

machining required on E75111/E75111 & E75211/E75210 for box locking parts on hinge side GU235812.00

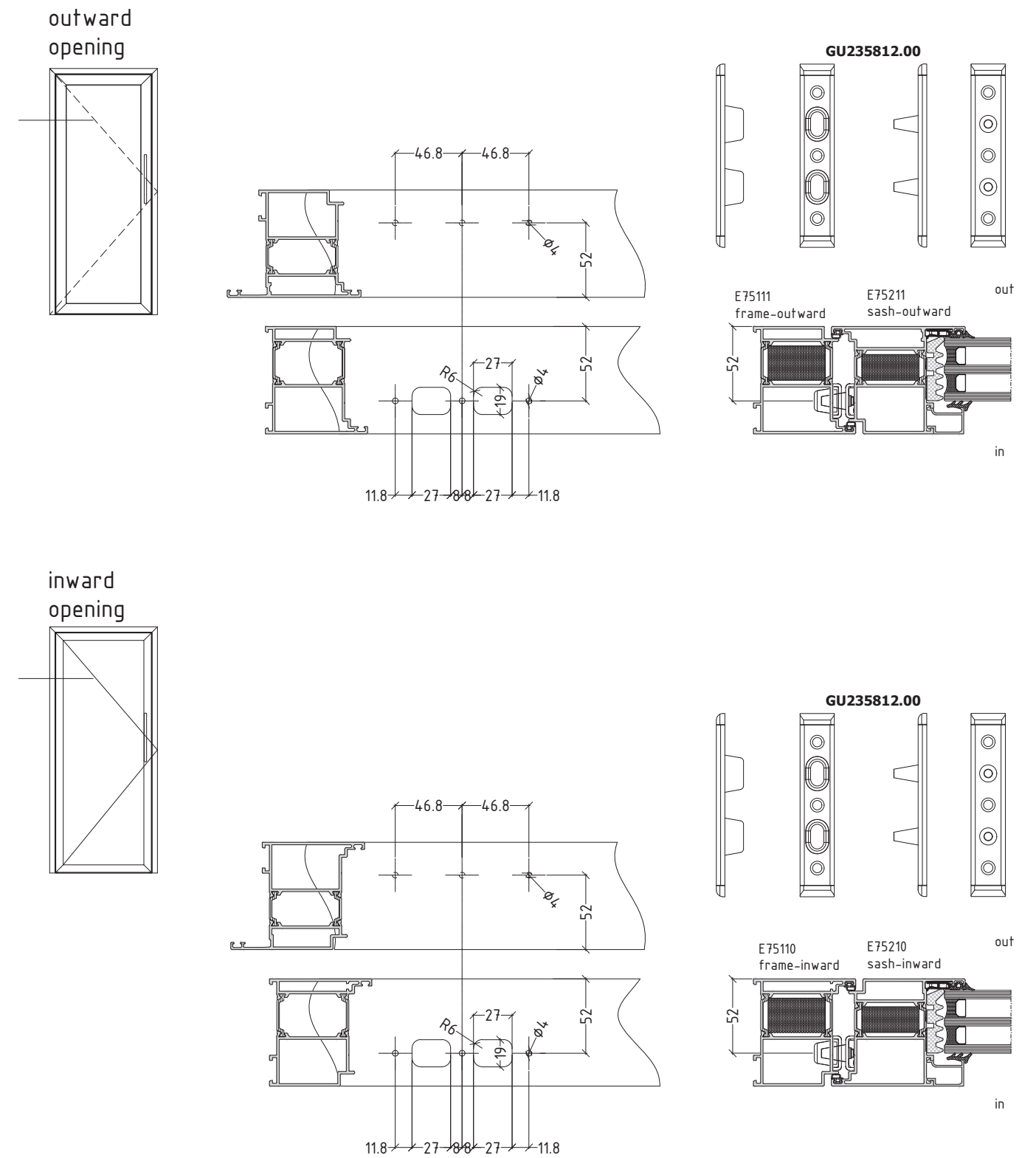

not to scale

M75D-63

# ACCESSORIES

# flat door system with thermal break

E75FD

code/description	package/pcs	colour
ET <b>130476.00</b>	60	●

EPDM gasket for glass  
elongated



ET <b>130153.00</b>	150	●
---------------------	-----	---

glazing EPDM gasket 4 mm



ET <b>130205.00</b>	125	●
---------------------	-----	---

glazing EPDM gasket  
press-in 5 mm



ET <b>990620.00</b>	125	●
---------------------	-----	---

glazing EPDM gasket  
press-in 6 mm



flat door system with thermal break

E75FD

code/description	package/pcs	colour
ET <b>130207.00</b>	75	●

glazing EPDM gasket  
press-in 7 mm



ET <b>130208.00</b>	40	●
---------------------	----	---

glazing EPDM gasket  
press-in 8 mm



ET <b>130210.00</b>	40	●
---------------------	----	---

glazing EPDM gasket  
press-in 10 mm



ET <b>130176.00</b>	80	●
---------------------	----	---

glazing EPDM gasket  
press-in 5-6 mm



A75D-2

flat door system with thermal break

E75FD

code/description	package/pcs	colour
ET <b>130177.00</b>	60	●

glazing EPDM gasket  
press-in 7-8 mm

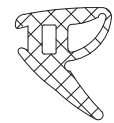

ET <b>130157.00</b>	200	●
---------------------	-----	---

EPDM gasket



ET <b>080751.00</b>	2	●
---------------------	---	---

additional insulator for E75

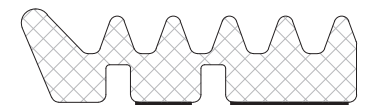

ET <b>130433.00</b>	70	●
---------------------	----	---

gasket for variable angle  
E75

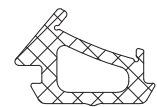

A75D-3

**flat door system with thermal break**

**E75FD**

code/description	package/pcs	colour
ET <b>130468.00</b>	100	●

outside silicone gasket



ET <b>130748.00</b>	100	●
---------------------	-----	---

EPDM gasket



ET <b>130491.00</b>	40	●
---------------------	----	---

EPDM gasket

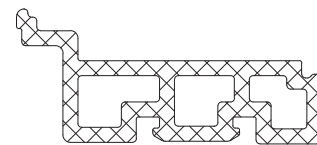

ET <b>995563.00</b>	1	●
---------------------	---	---

SET 1.1KSTP

set pl. plugs for  
single-sash flat door with  
thermal threshold

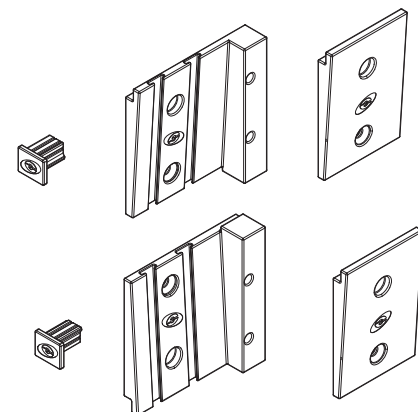

A75D-4

**flat door system with thermal break**

**E75FD**

code/description	package/pcs	colour
ET <b>995564.00</b>	1	●

SET 2.1KCCH

set pl. plugs for  
single-sash flat door with  
brush holder

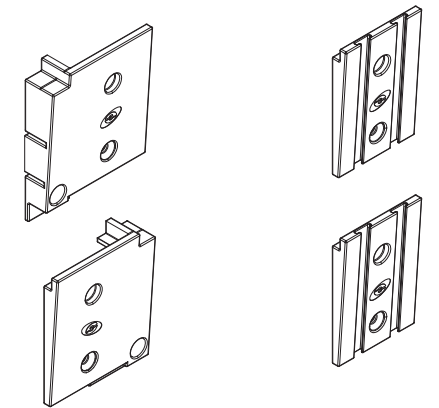

ET <b>995565.00</b>	1	●
---------------------	---	---

SET 3.1KSP

set pl. plugs for  
single-sash flat door with  
kick-plate

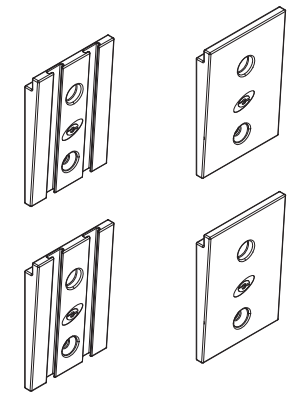

ET <b>995566.00</b>	1	●
---------------------	---	---

SET 4.2KSTP

set pl. plugs for  
double-sash flat door with  
thermal threshold

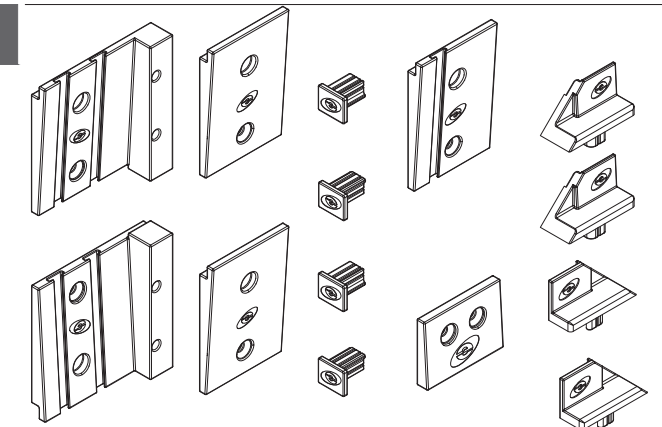

ET <b>995567.00</b>	1	●
---------------------	---	---

SET 5.2KSCH

set pl. plugs for  
double-sash flat door with  
brush holder

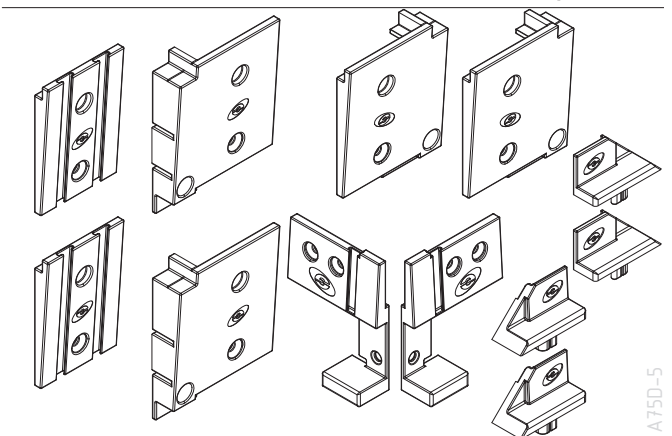

A75D-5



**flat door system with thermal break**

**E75FD**

code/description	package/pcs	colour
ET <b>995568.00</b>	1	●

SET 6.2KSP

set pl. plugs for  
double-sash flat door with  
kick-plate

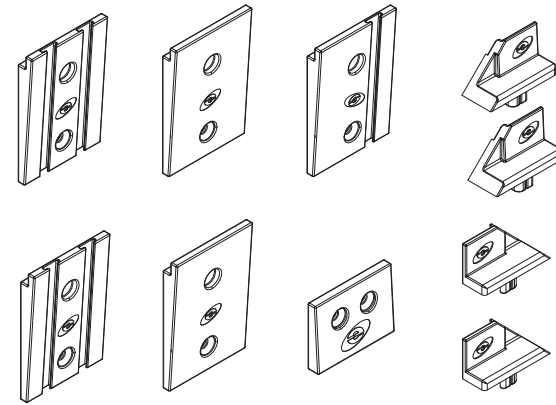

ET <b>991306.00</b>	200	●
---------------------	-----	---

equalizing shim 6 mm

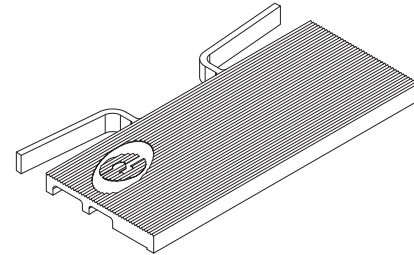

ET <b>074306.00</b>	100	●
---------------------	-----	---

plastic drainage cap 30x6mm

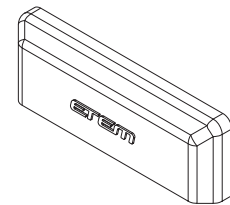

ET <b>074307.00</b>	100	●
---------------------	-----	---

flap for drainage cap

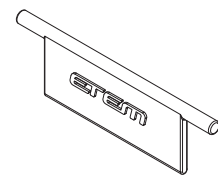

A75D-6

**flat door system with thermal break**

**E75FD**

code/description	package/pcs	colour
ET <b>074629.00</b>	200	nickel

plastic plug for drip profile  
E2357

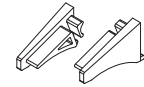

ET <b>055516.00</b>	1	-
---------------------	---	---

Steel anchor for E75

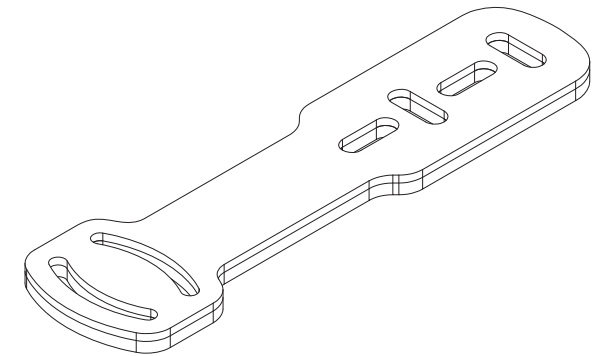

ET <b>054674.00</b>	200	MF
---------------------	-----	----

extruded aluminium corner  
bracket 6.4 mm for  
E75111

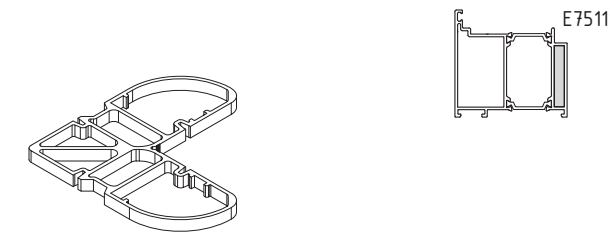

attention  
always use epoxy resin  
for long lasting joining

ET <b>054675.00</b>	50	MF
---------------------	----	----

extruded aluminium corner  
bracket 30.4 mm for  
E75111/E75210

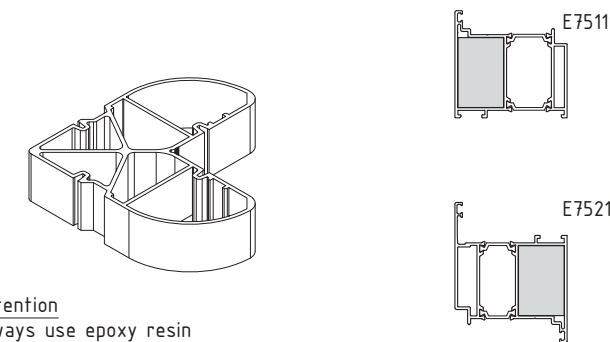

attention  
always use epoxy resin  
for long lasting joining

A75D-7

flat door system with thermal break

E75FD

code/description	package/pcs	colour
ET <b>054676.00</b>	200	MF

extruded aluminium corner bracket 3.9 mm for E75210

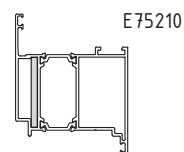
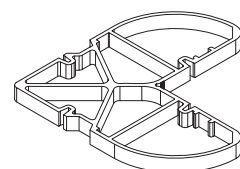

attention  
always use epoxy resin  
for long lasting joining

ET <b>054670.00</b>	150	MF
---------------------	-----	----

extruded aluminium corner bracket 6.4 mm for E75110

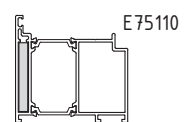
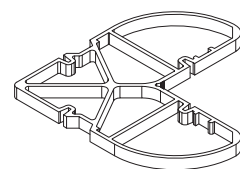

attention  
always use epoxy resin  
for long lasting joining

ET <b>054671.00</b>	100	MF
---------------------	-----	----

extruded aluminium corner bracket 21.9 mm for E75110/E75211

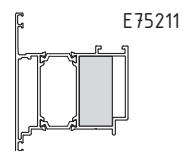
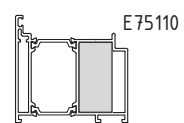
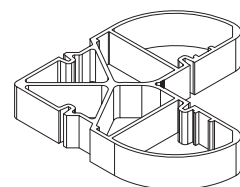

attention  
always use epoxy resin  
for long lasting joining

ET <b>054672.00</b>	100	MF
---------------------	-----	----

extruded aluminium corner bracket 8.2 mm for E75110/E75211

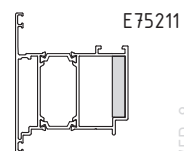
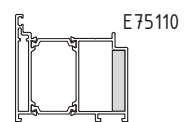
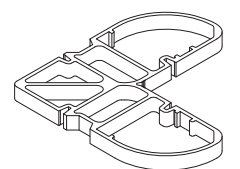

attention  
always use epoxy resin  
for long lasting joining

A75D-8

flat door system with thermal break

E75FD

code/description	package/pcs	colour
ET <b>054673.00</b>	100	MF

extruded aluminium corner bracket 12.4 mm for E75211

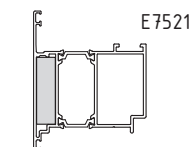
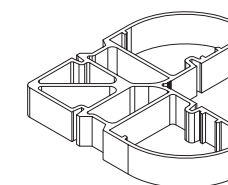

attention  
always use epoxy resin  
for long lasting joining

ET <b>054553.00</b>	100	MF
---------------------	-----	----

extruded aluminium corner bracket

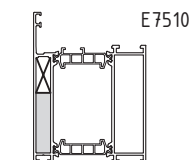
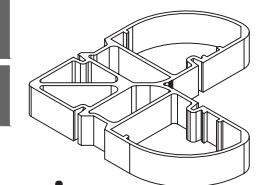

+

extruded aluminium shimming corner

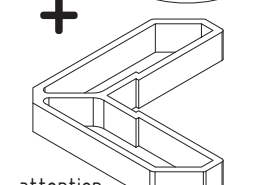

attention  
always use epoxy resin  
for long lasting joining

ET <b>054311.00</b>	100	MF
---------------------	-----	----

extruded aluminium corner bracket

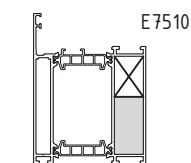
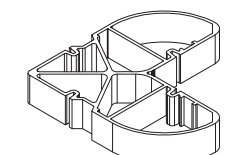

+

extruded aluminium shimming corner

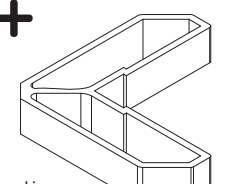

attention  
always use epoxy resin  
for long lasting joining

ET <b>054722.00</b>	75	MF
---------------------	----	----

extruded aluminium corner bracket 30.7 mm for E75112

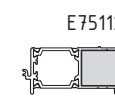
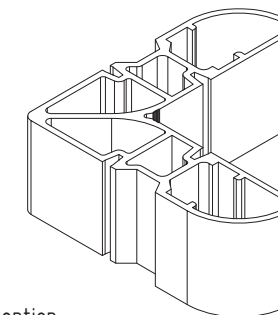

attention  
always use epoxy resin  
for long lasting joining

A75D-9

**flat door system with thermal break**

**E75FD**

code/description	package/pcs	colour
ET <b>055511.00</b>	100	MF

alignment square - inox  
for E75112

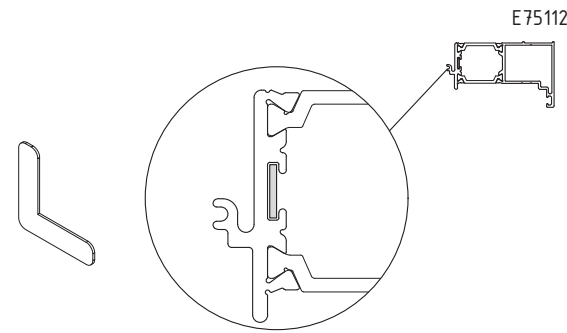

ET <b>058001.00</b>	250	MF
---------------------	-----	----

alignment square with  
locking function

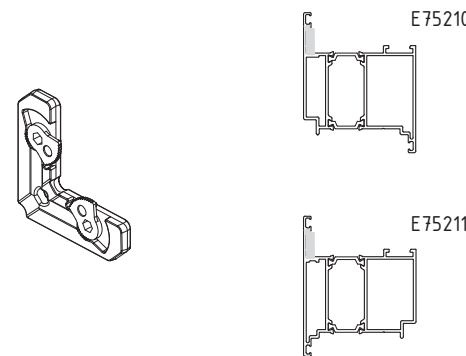

ET <b>991407.00</b>	10	MF
---------------------	----	----

T - bracket external side for  
E75300/E75340

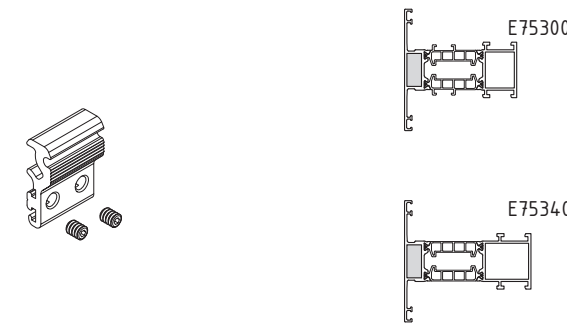

ET <b>070206.00</b>	10	MF
---------------------	----	----

T - bracket internal side for  
E75300/E75340

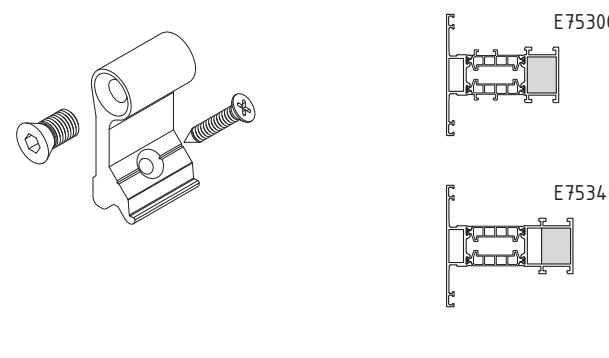

A75D-10

**flat door system with thermal break**

**E75FD**

code/description	package/pcs	colour
ET <b>070308.00</b>	10	MF

T - bracket external side



ET <b>070212.00</b>	10	MF
---------------------	----	----

T - bracket internal side

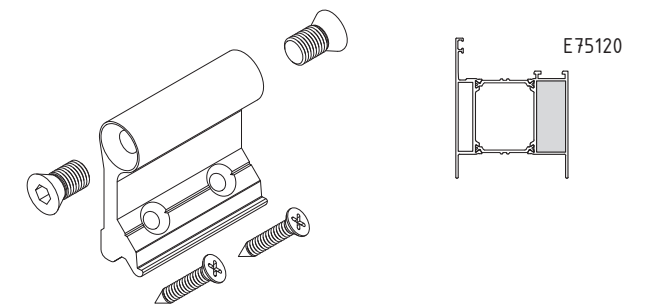

ET <b>070310.00</b>	10	MF
---------------------	----	----

T - bracket external side

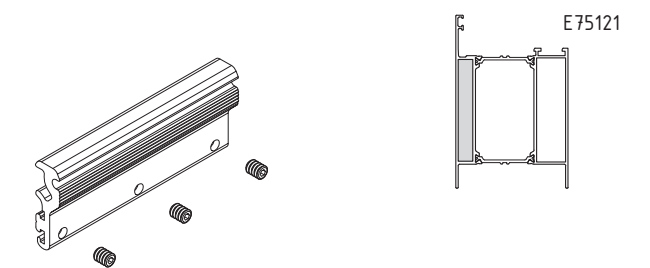

ET <b>070214.00</b>	10	MF
---------------------	----	----

T - bracket internal side

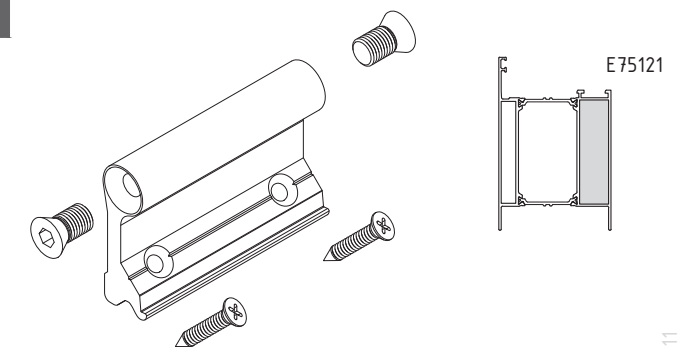

A75D-11

flat door system with thermal break

E75FD

code/description	package/pcs	colour
ET <b>070309.00</b>	10	MF

T - bracket external side

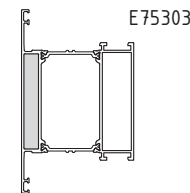
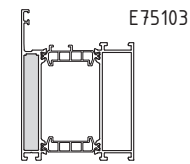
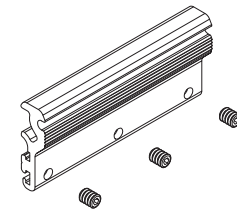

ET <b>070213.00</b>	10	MF
---------------------	----	----

T - bracket internal side

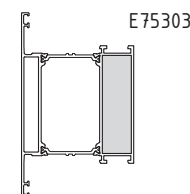
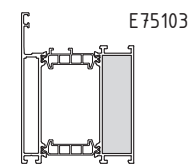
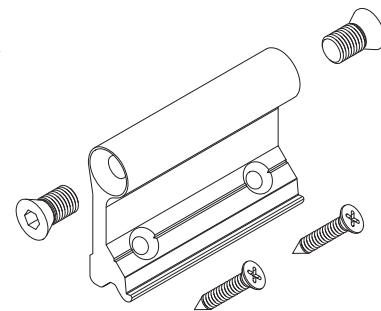

<b>GI205035.01</b>	10	●
<b>GI205035.04</b>	10	●
<b>GI205035.02</b>	10	●

double hinge for flat door  
Domina

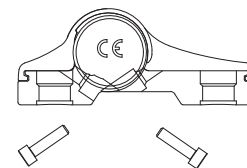
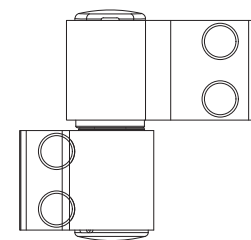

ET <b>GI205042.01</b>	5	●
ET <b>GI205042.02</b>	5	●
ET <b>GI205042.11</b>	5	●

triple hinge for flat door  
Domina

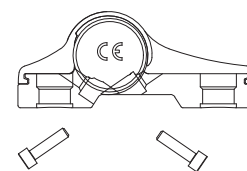
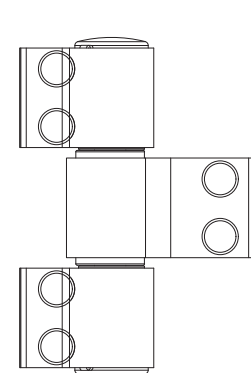

A75D-12

flat door system with thermal break

E75FD

code/description	package/pcs	colour
<b>GI205039.00</b>	24	MF

bolt adjustable spacer 48mm  
for hinge Domina

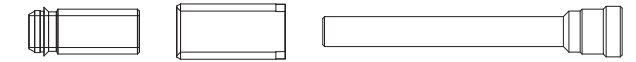

<b>GI255616.00</b>	24	MF
--------------------	----	----

conter plate kit for hinge  
Domina

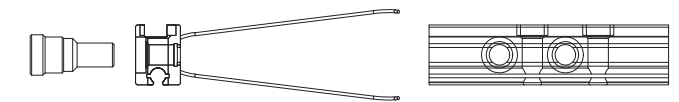

<b>GI051660.01</b>	1	●
<b>GI051660.02</b>	1	●
<b>GI051660.11</b>	1	EV1

double hinge for flat door  
Domina - 84mm

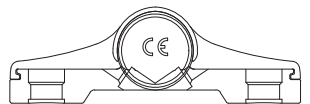
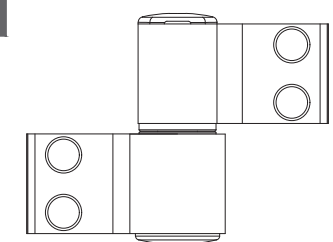

<b>GI205040.01</b>	1	●
<b>GI205040.02</b>	1	●
<b>GI205040.11</b>	-	EV1

triple hinge for flat door  
Domina - 84mm

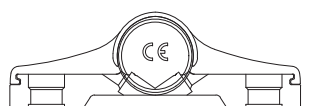
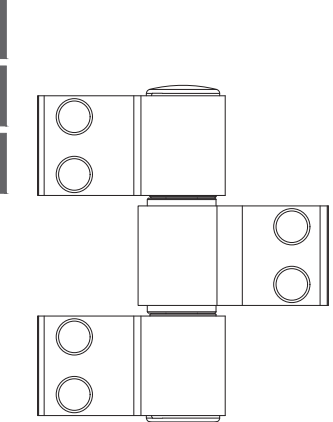

A75D-13

flat door system with thermal break

E75FD

code/description	package/pcs	colour
<b>GI205044.00</b>	24	MF

expansion plugs Domina

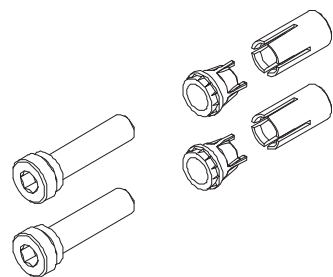

<b>GI 205040.00</b>	20	MF
---------------------	----	----

direct screw 12x75 for hinge Domina

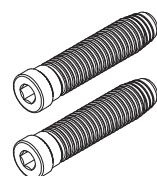

<b>ET 205114.01</b>	2	●
<b>ET 205114.02</b>	2	●
<b>ET 205114.11</b>	2	EV1

hinge ETEM Alpro

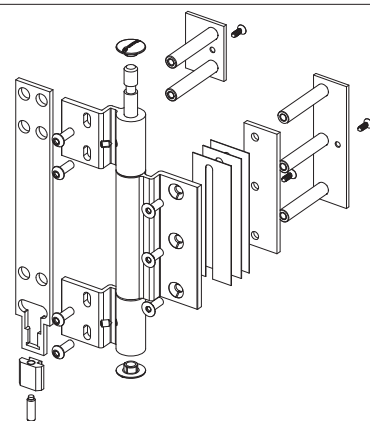

<b>ET 205101.06</b>	1	●
<b>ET 205101.02</b>	1	●

hidden hinge Simonswerk TECTUS

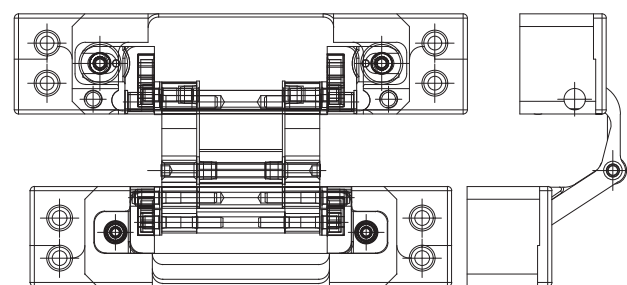

A75D-14

flat door system with thermal break

E75FD

code/description	package/pcs	colour
<b>ET 205102.00</b>	1	MF

fixing set for TECTUS

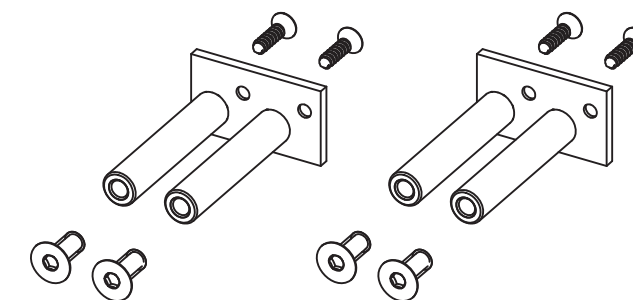

<b>GU235824.00</b>	1	-
--------------------	---	---

cylinder 35/65mm

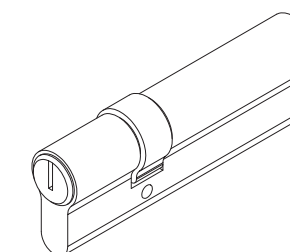

<b>GU 238893.00</b>	1	nickel
---------------------	---	--------

Security lock GU 35/92/240



<b>GU235841.00</b>	1	-
--------------------	---	---

Striker Up/Bottom

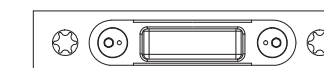

A75D-15

flat door system with thermal break

E75FD

code/description	package/pcs	colour
<b>GU235804.00</b>	1	-

Middle strike plate  
Left

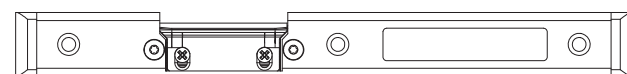

<b>GU235805.00</b>	1	-
--------------------	---	---

Middle strike plate  
Right

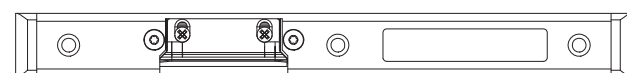

<b>GI02790.01</b>	10	●
<b>GI02790.06</b>	10	●
<b>GI02790.02</b>	10	●

Double handle for door prima

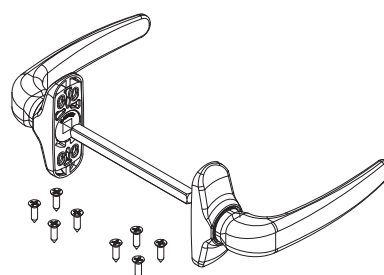

<b>GI206672.01</b>	10	●
<b>GI206670.02</b>	10	●
<b>GI206671.06</b>	10	●

cover plate for cilinder

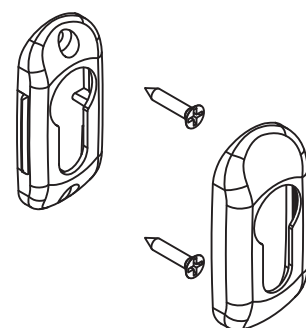

A75D-16

flat door system with thermal break

E75FD

code/description	package/pcs	colour
<b>GI039910.01</b>	10	●
<b>GI039910.02</b>	10	●
<b>GI039910.06</b>	10	●
<b>GI039910.12</b>	10	EV1 brushed

NP ultra door handle squared

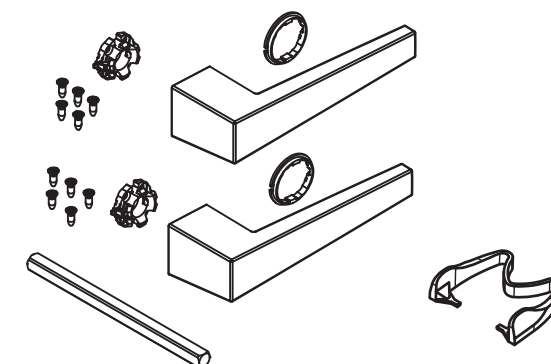

<b>GI039920.01</b>	10	●
<b>GI039920.02</b>	10	●
<b>GI039920.06</b>	10	●
<b>GI039920.12</b>	10	EV1 brushed

NP ultra door handle rounded

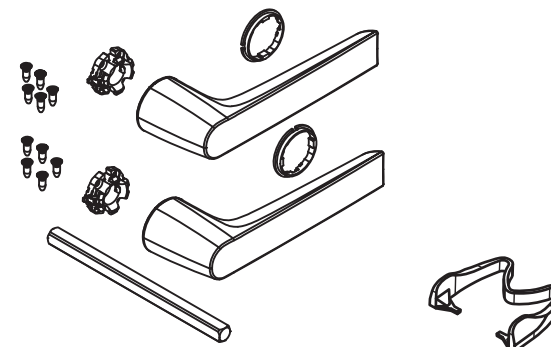

<b>GI050440.01</b>	10	●
<b>GI050440.02</b>	10	●
<b>GI050440.06</b>	10	●
<b>GI050440.12</b>	10	EV1 brushed

NP ultra door handle ETEM

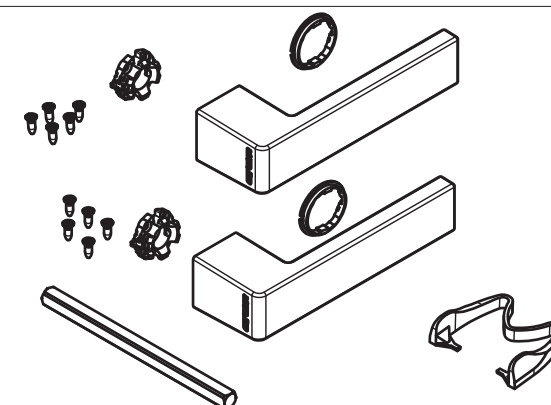

<b>GU24315.01</b>	10	●
<b>GU24315.02</b>	10	●
<b>GU24315.06</b>	10	●
<b>GU24315.12</b>	10	EV1 brushed

cylinder cover squared

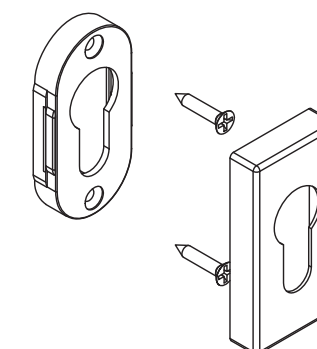

A75D-17

flat door system with thermal break

E75FD

code/description	package/pcs	colour
ET <b>994573.00</b>	10	●

bolt for secondary sash  
GIESSE

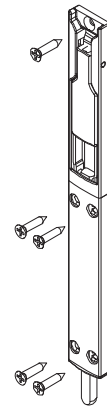

<b>GU235812.00</b>	1	-
--------------------	---	---

box locking parts on hinge  
side U24x6

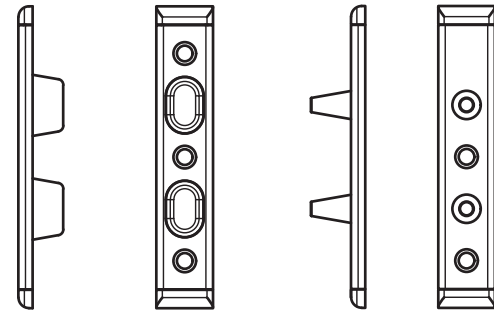

<b>GI206699.00</b>	100	nickel
--------------------	-----	--------

striker for treshold giesse

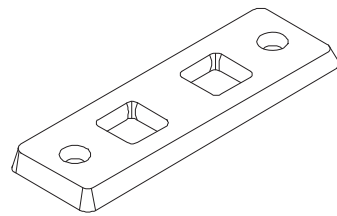

<b>GI206682.00</b>	10	-
--------------------	----	---

bottom striker for side hung  
bolt

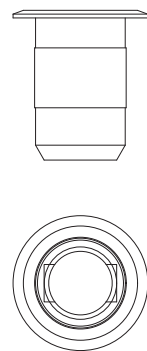

A75D-18

flat door system with thermal break

E75FD

code/description	package/pcs	colour
<b>GI206681.00</b>	10	-

upper striker for side hung  
bolt

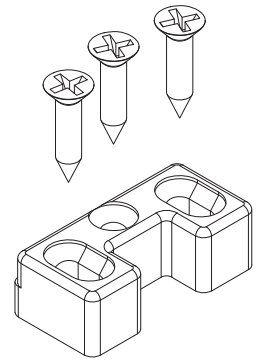

ET <b>074075.00</b>	1	-
---------------------	---	---

striker plate

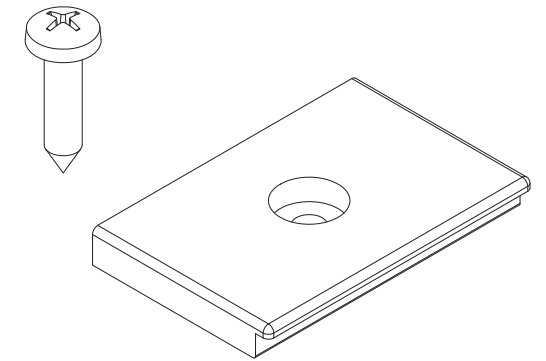

ET <b>080525.00</b>	2m	standard
---------------------	----	----------

additional insulator for  
E75110  
E75111

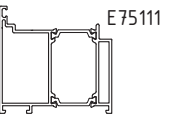
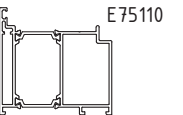
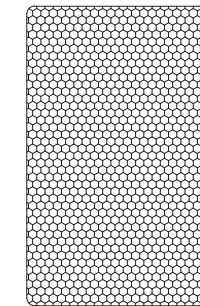

ET <b>080526.00</b>	2m	standard
---------------------	----	----------

additional insulator for  
E75210  
E75211

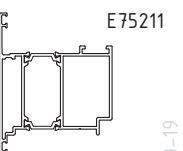
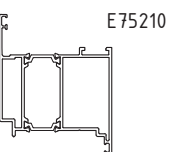
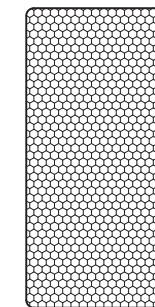

A75D-19

flat door system with thermal break

E75FD

code/description	package/pcs	colour
FA 134251.00	1	-

Automatic door sealing systems - 1000 mm

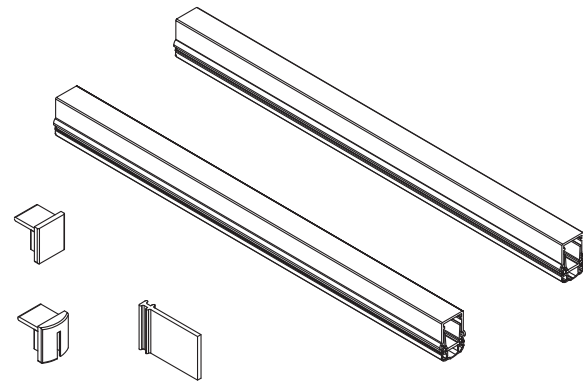

E75FPD

# FLAT PANEL DOOR SYSTEM WITH THERMAL BREAK

A75D-20



# GENERAL INFORMATION

CONCEPT / ADVANTAGES / CERTIFICATES



# E75FPD SYSTEM CONCEPT

**E75FPD** FLAT DOOR SYSTEM IS A PREMIUM SOLUTION ENSURING EXCELLENT THERMAL INSULATION, COMFORT AND EXQUISITE APPEARANCE.

- Elegant straight design
- 75 mm system width allowing usage of triple glazing
- Flushing between opening parts and fixed positions
- Double sash flat doors
- Additional insulator in the thermo-break area
- Additional insulator under the glass
- Anti bi-metal polyamide
- Possibility for automatization
- Opportunity for manufacturing sashes with big dimensions
- Possibility for mounting anti-burglar hardware for good security performance
- Extruded corners for crimping machine with glue allowing greater connections

# TABLES

TYPES / LIST OF PROFILES / CHARACTERISTICS

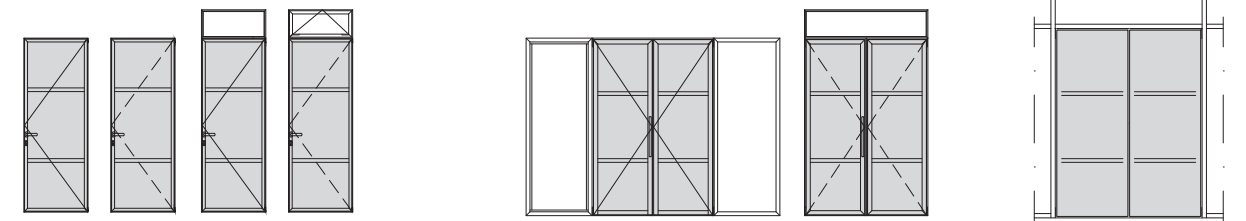

not to scale

# flat door system with thermal break

E75FPD

code	profile	weight length moment of inertia	code	profile	weight length moment of inertia
E75110 frame-inward		L=6.01 m 1932 g/m Ix=27.25 cm <sup>4</sup> Iy=49.95 cm <sup>4</sup>	E75601 adapter for facade		L=6.01 m 897 g/m Ix=1.52 cm <sup>4</sup> Iy=10.95 cm <sup>4</sup>
E75111 frame-outward		L=6.01 m 1891 g/m Ix=26.58 cm <sup>4</sup> Iy=49.88 cm <sup>4</sup>	E75605 adapter		L=6.01 m 274 g/m
E75271 sash-inward		L=6.01 m 1771 g/m Ix=22.44 cm <sup>4</sup> Iy=36.39 cm <sup>4</sup>	E75112 reverse profile		L=6.01 m 1164 g/m Ix=5.14 cm <sup>4</sup> Iy=22.84 cm <sup>4</sup>
E75270 sash-outward		L=6.01 m 1768 g/m Ix=22.45 cm <sup>4</sup> Iy=35.63 cm <sup>4</sup>	E75602 adapter		L=6.01 m 216 g/m
E75372 T-profile		L=6.01 m 1216 g/m Ix=8.03 cm <sup>4</sup> Iy=22.3 cm <sup>4</sup>	E75603 round column		L=6.01 m 2232 g/m Ix=56.34 cm <sup>4</sup> Iy=55.75 cm <sup>4</sup>
E75655 connecting profile		L=6.01 m 941 g/m Ix=0.98 cm <sup>4</sup> Iy=19.48 cm <sup>4</sup>	E75810 door threshold		L=6.01 m 722 g/m

L E75 FPD-01

# flat door system with thermal break

E75FPD

code	profile	weight length moment of inertia	code	profile	weight length moment of inertia
E75811 door threshold		L=6.01 m 723 g/m			
E75800 brush-holder		L=6.01 m 497 g/m			
E75802 bottom rail		L=6.01 m 85 g/m			
E75805 bottom rail		L=6.01 m 210 g/m			

# PROFILES

DRAWINGS

E75110  
1932 g/m

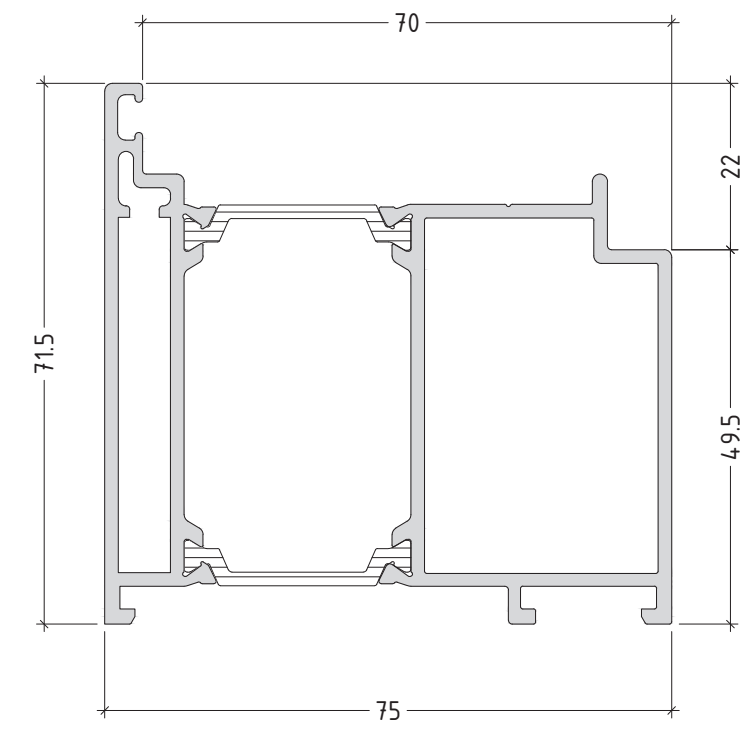

E75111  
1891 g/m

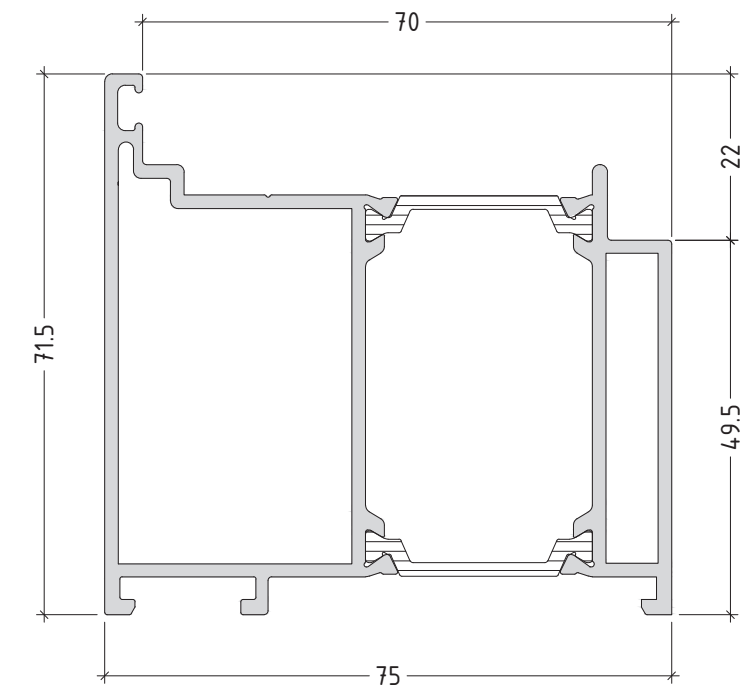

scale : 1:1

flat panel door system with thermal break

E75FPD

E75271  
1771 g/m

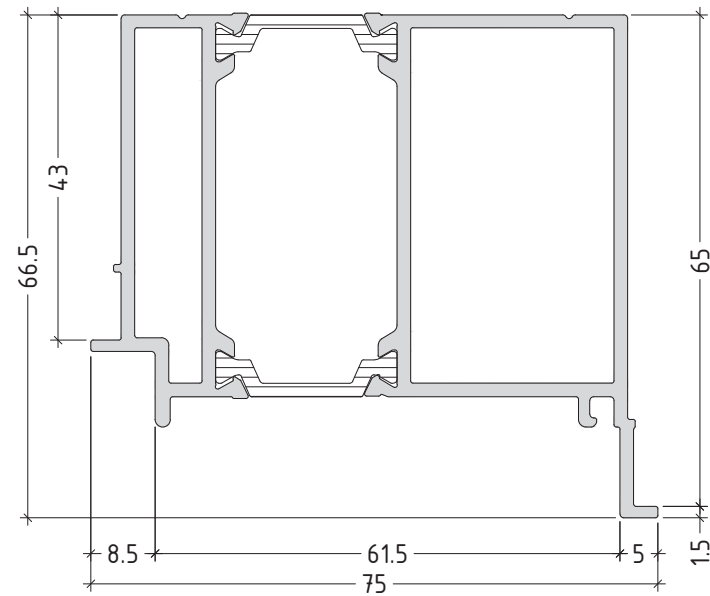

E75270  
1768 g/m

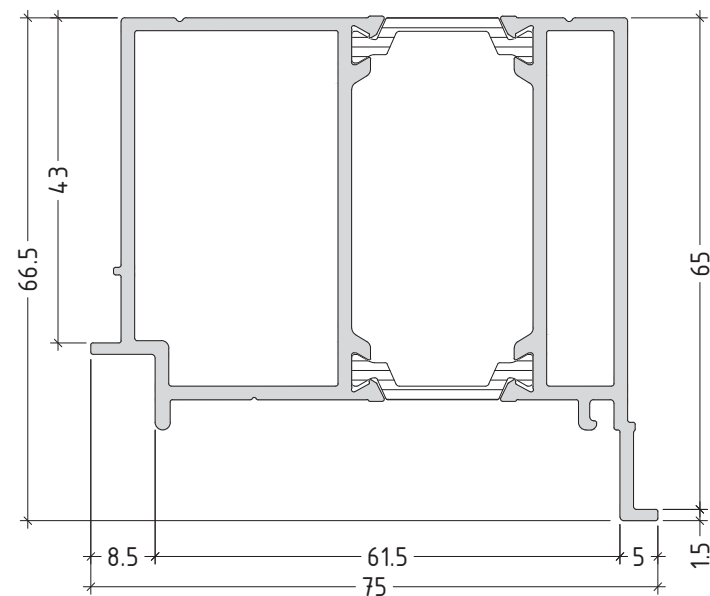

scale : 1:1

P E75 FPD-02

flat panel door system with thermal break

E75FPD

E75372  
1216 g/m

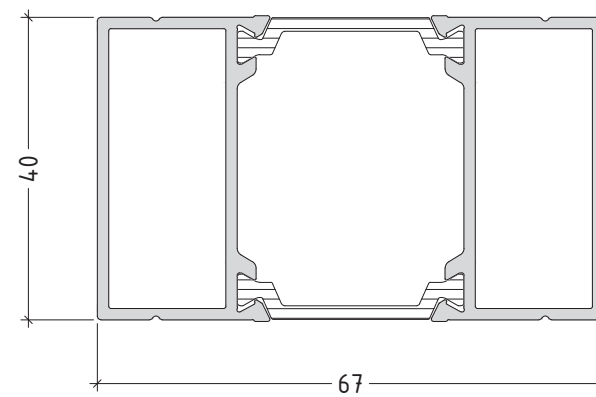

E75655  
941 g/m

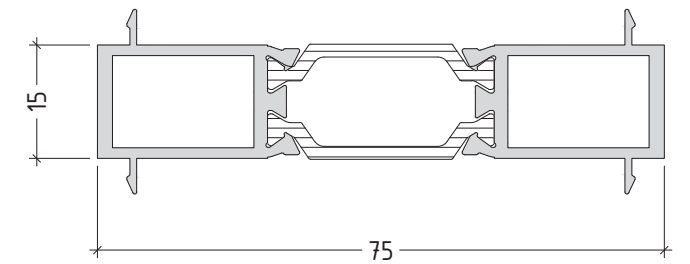

E75601  
897 g/m

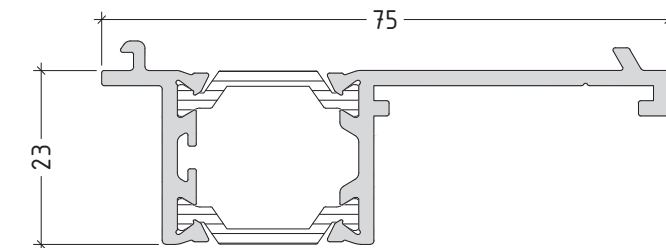

E75605  
274 g/m

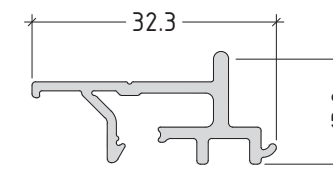

E75112  
1164 g/m

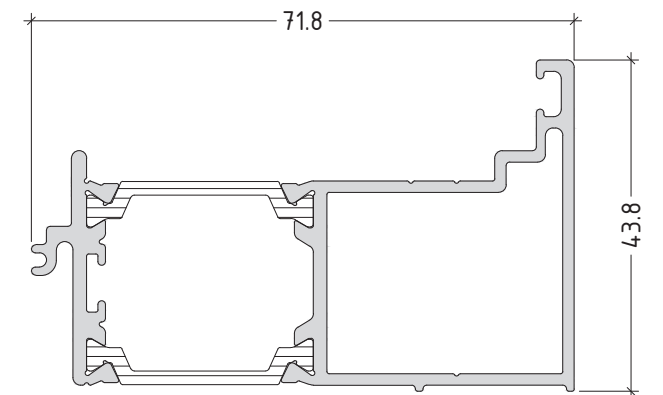

scale : 1:1

P E75 FPD-03



flat panel door system with thermal break

E75FPD

E75602  
216 g/m

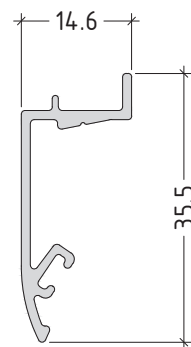

E75603  
2232 g/m

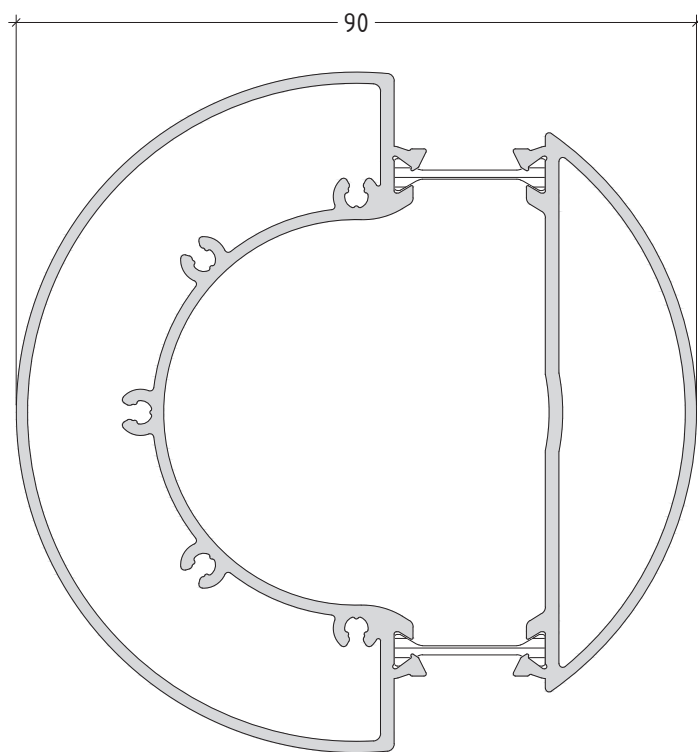

scale : 1:1

P E75 FPD-04

flat panel door system with thermal break

E75FPD

E75810  
722 g/m

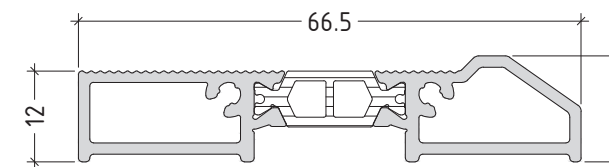

E75811  
723 g/m

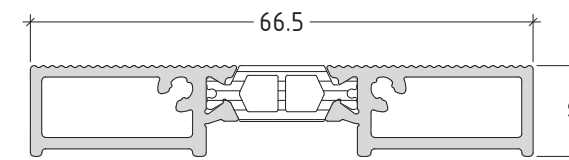

E75805  
210 g/m

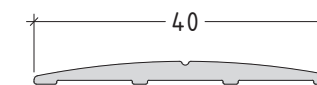

E75800  
497 g/m

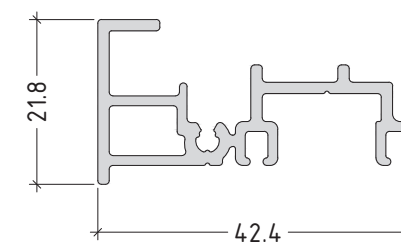

E75802  
85 g/m

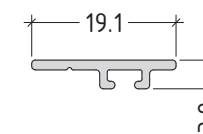

scale : 1:1

P E75 FPD-05

# SECTIONS

SECTIONS / DETAILS

outward opening

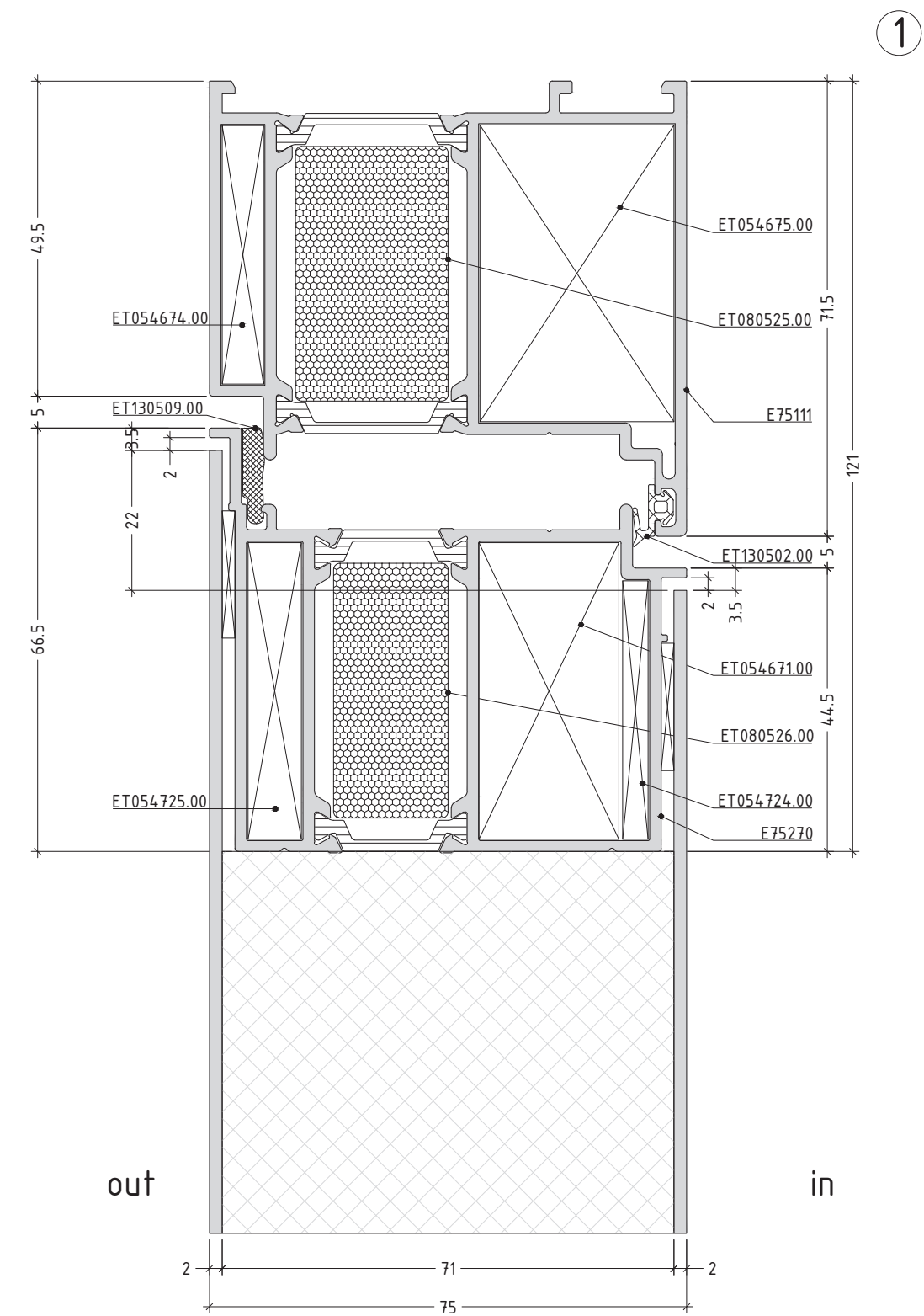
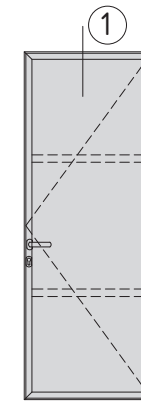

scale : 1:1

flat panel door system with thermal break

E75FPD

outward opening

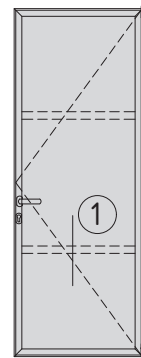

①  
out

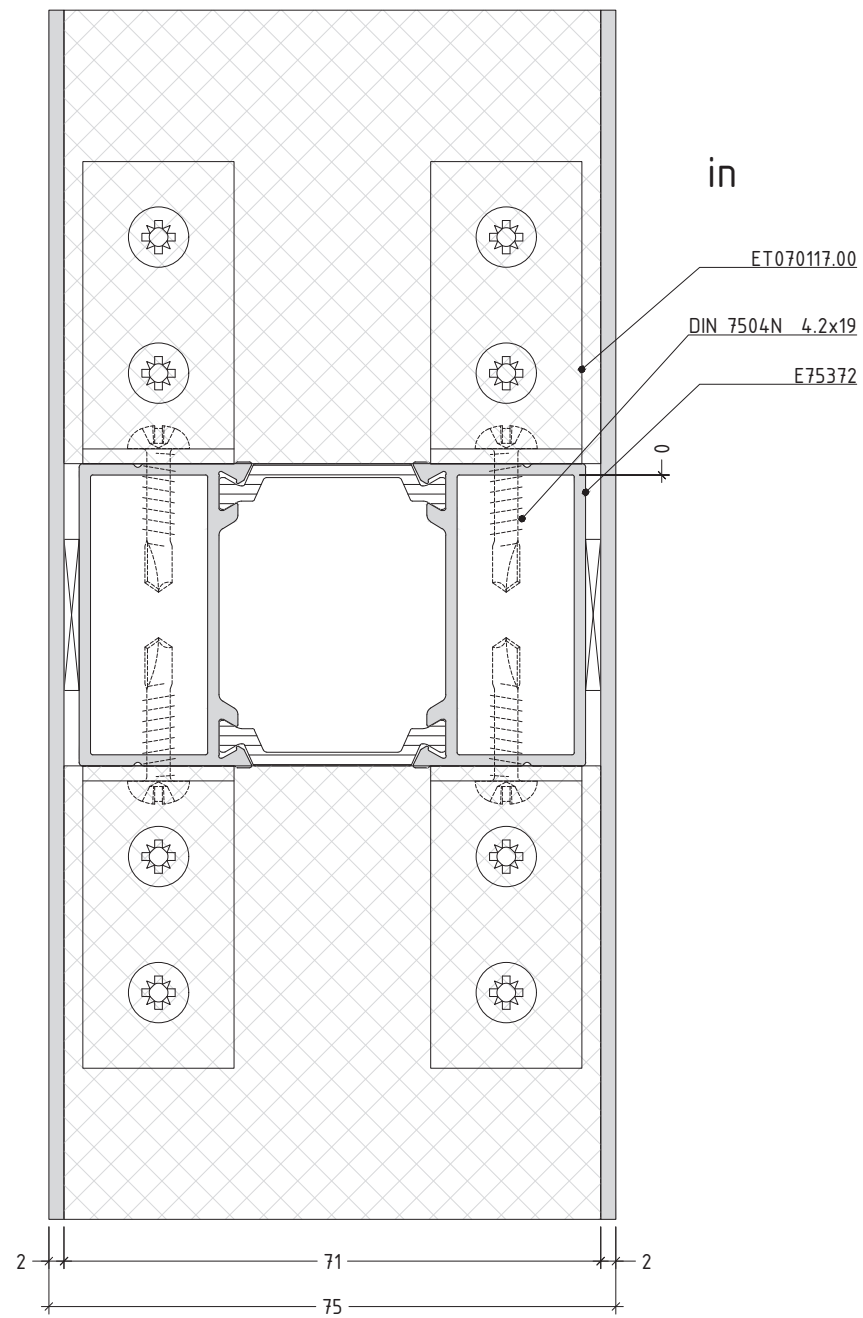

Note:  
For inward opening detail is the same!  
scale : 1:1

D E75 FPD-2

flat panel door system with thermal break

E75FPD

outward opening

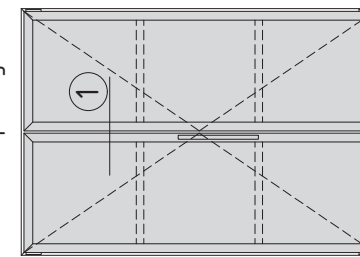

①

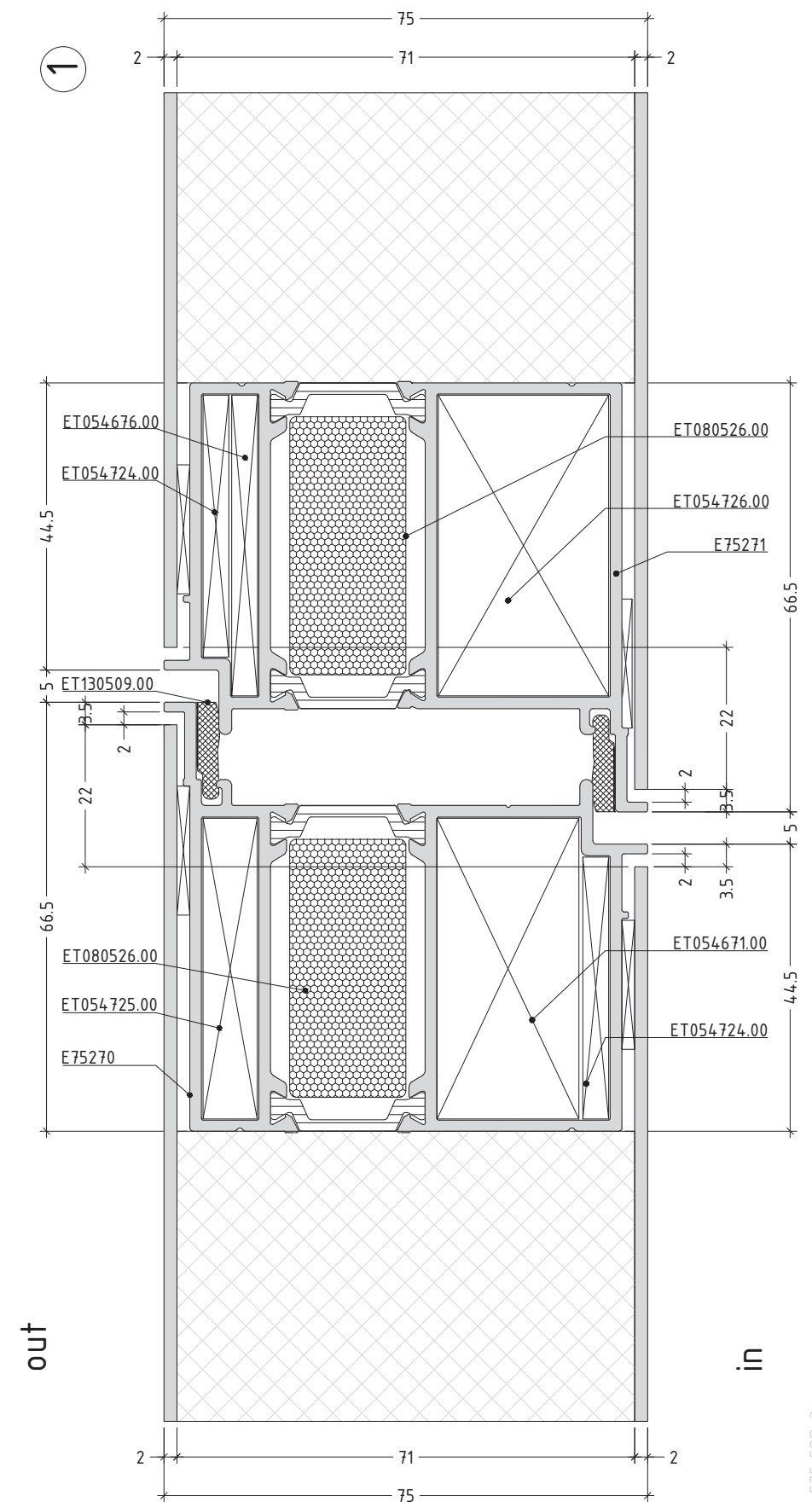

out

in

scale : 1:1

D E75 FPD-3

flat panel door system with thermal break

E75FPD

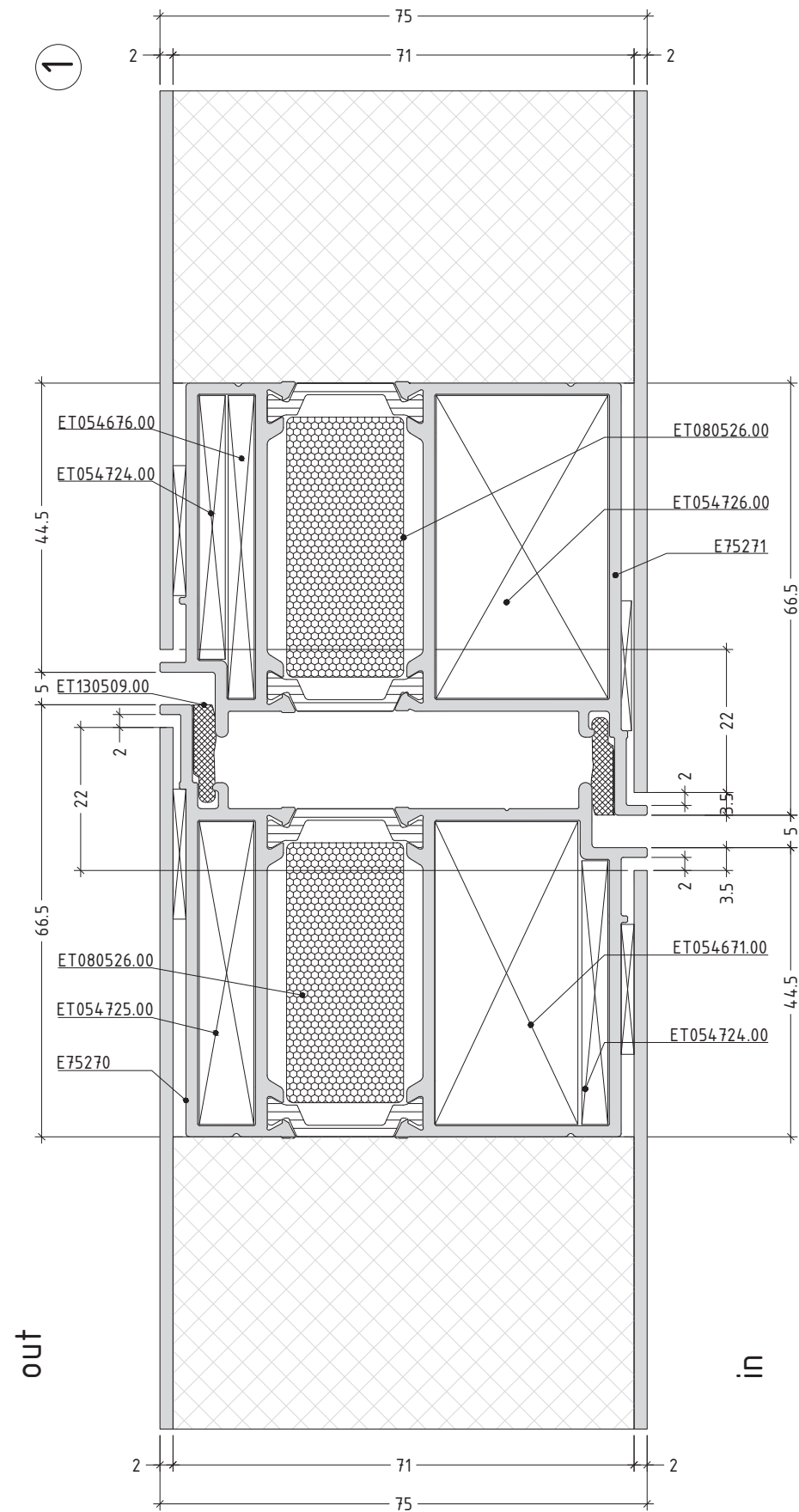
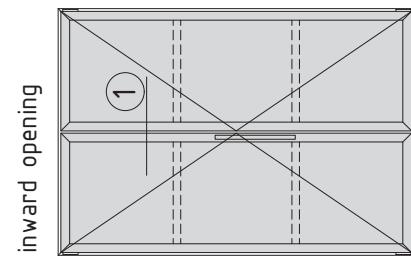

scale : 1:1

D E75 FPD-4

flat panel door system with thermal break

E75FPD

outward opening

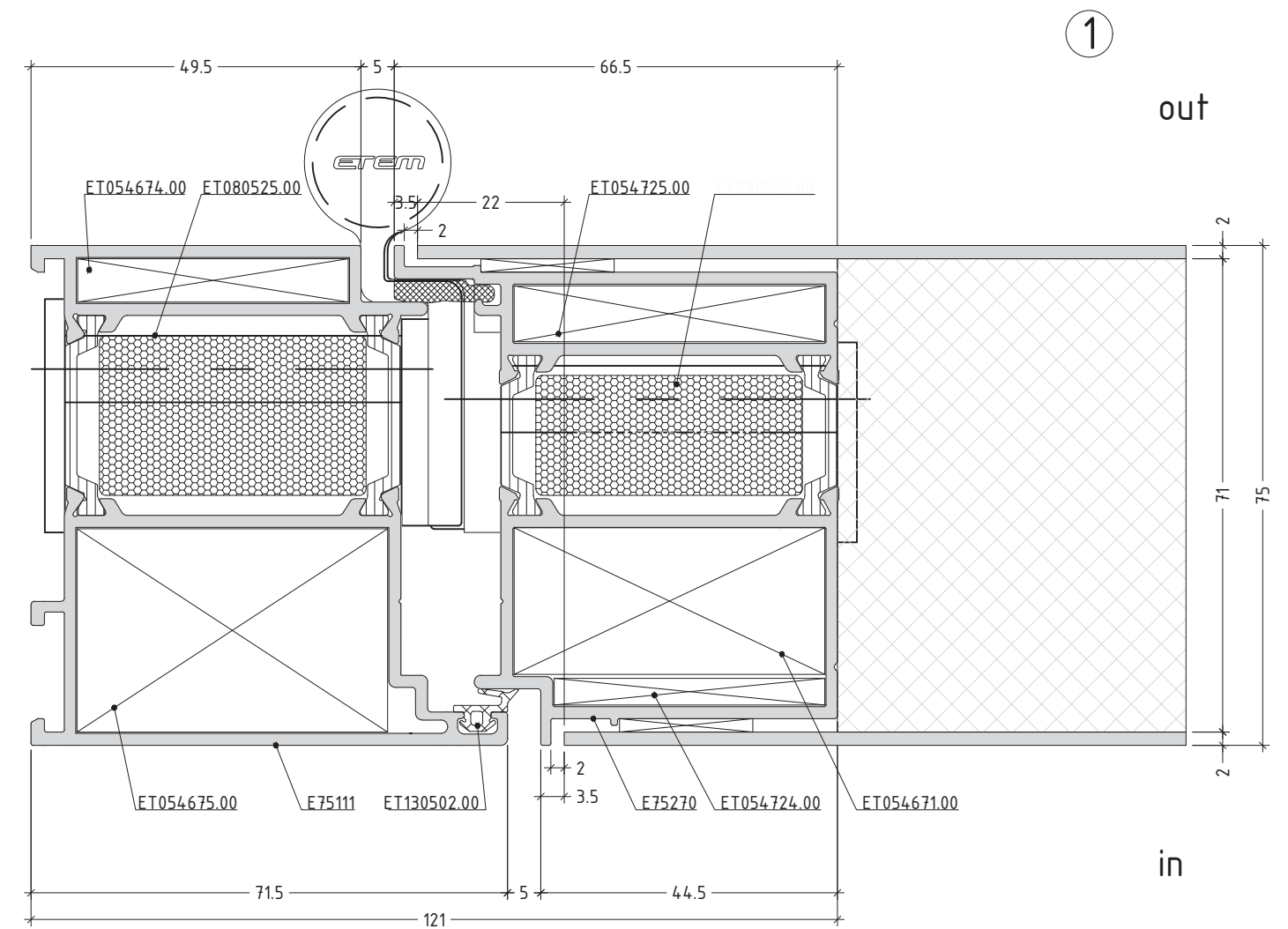
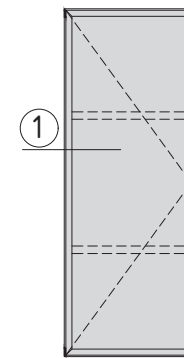

scale : 1:1

D E75 FPD-5

flat panel door system with thermal break

E75FPD

inward opening

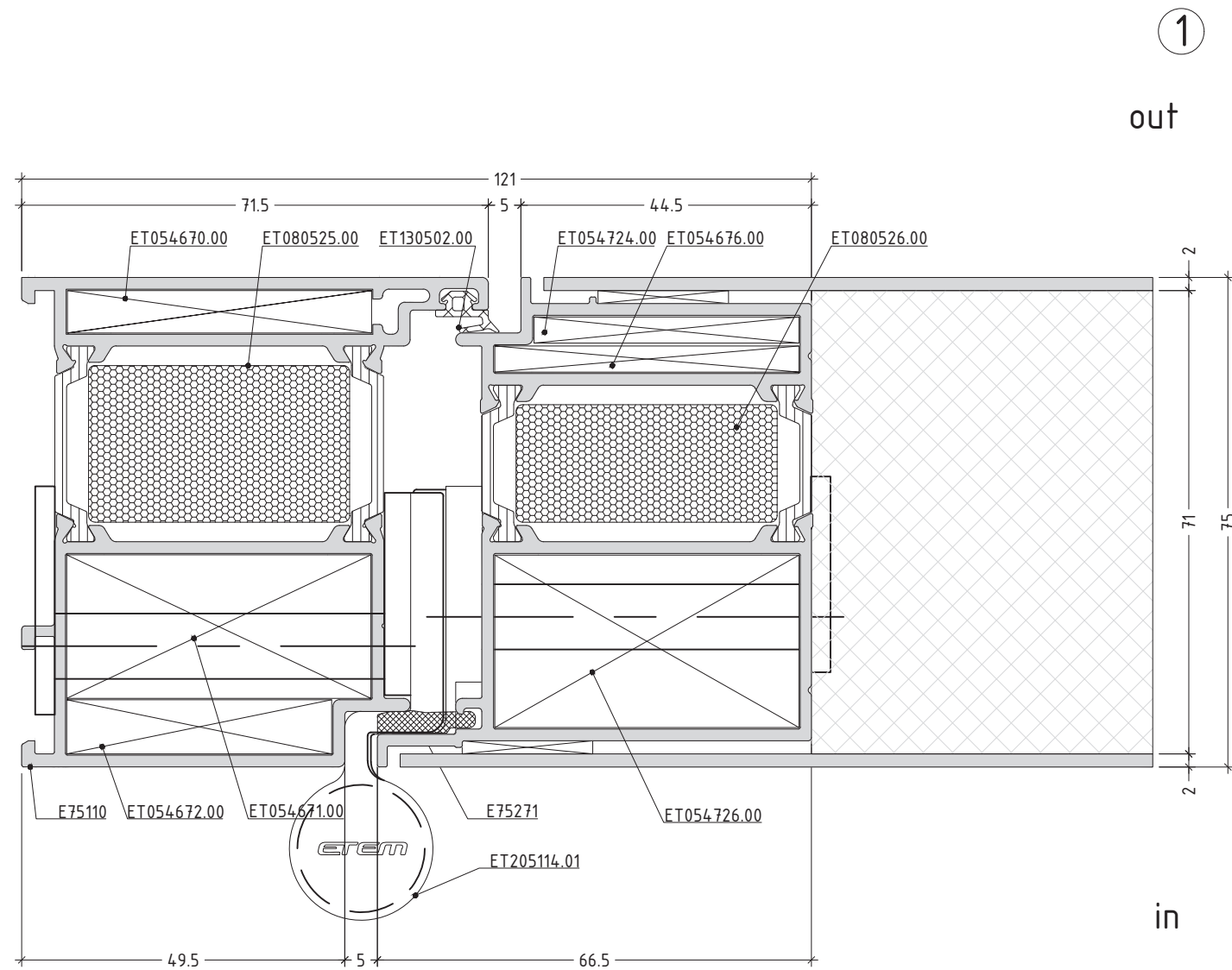
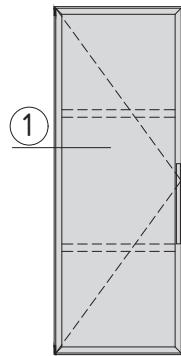

scale : 1:1

D E75 FPD-6

flat panel door system with thermal break

E75FPD

inward opening

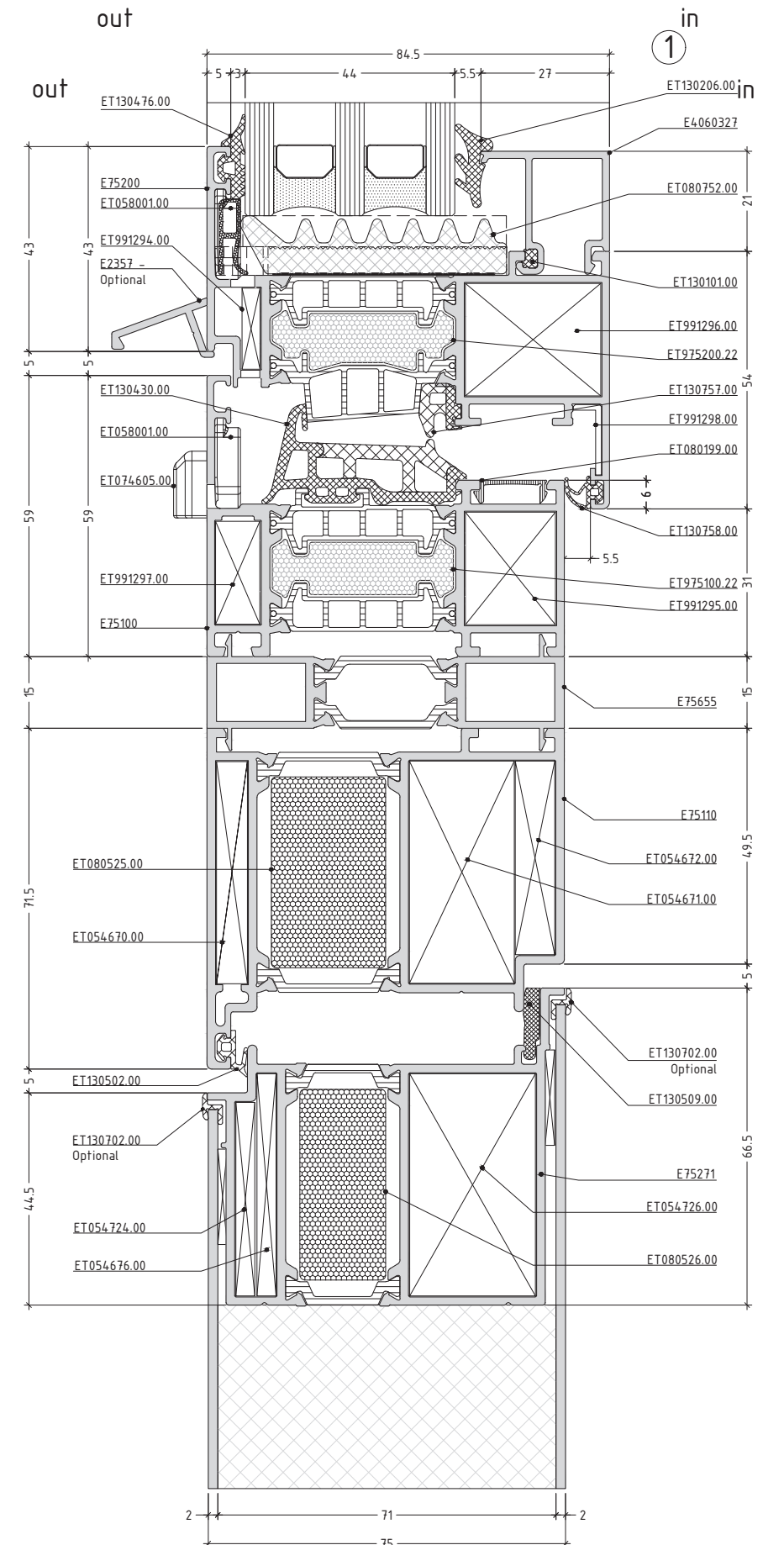
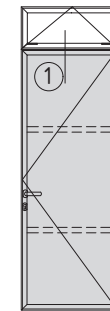

scale : 3/4

D E75 FPD-7

flat panel door system with thermal break

E75FPD

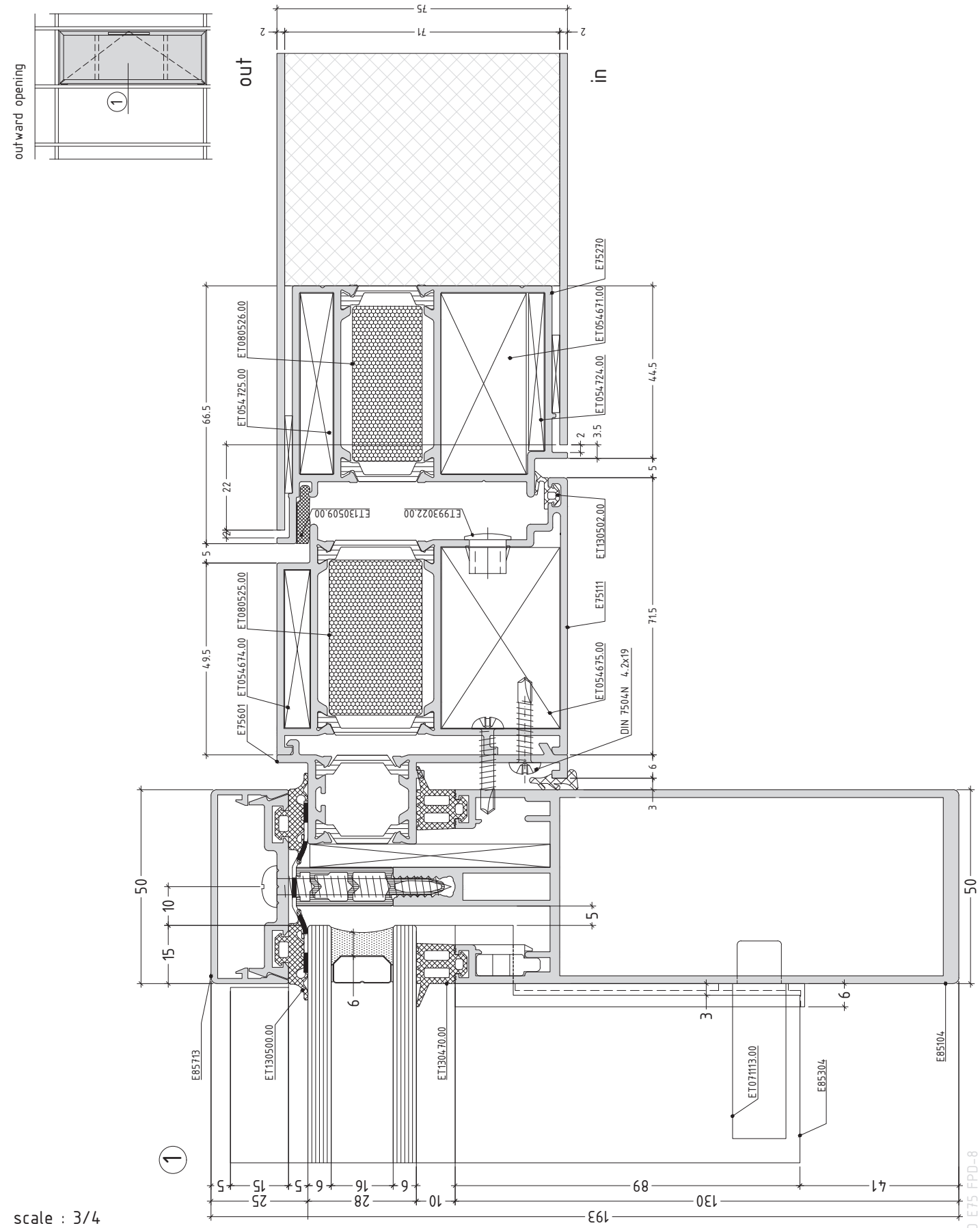

scale : 3/4

D E75 FPD-8

flat panel door system with thermal break

E75FPD

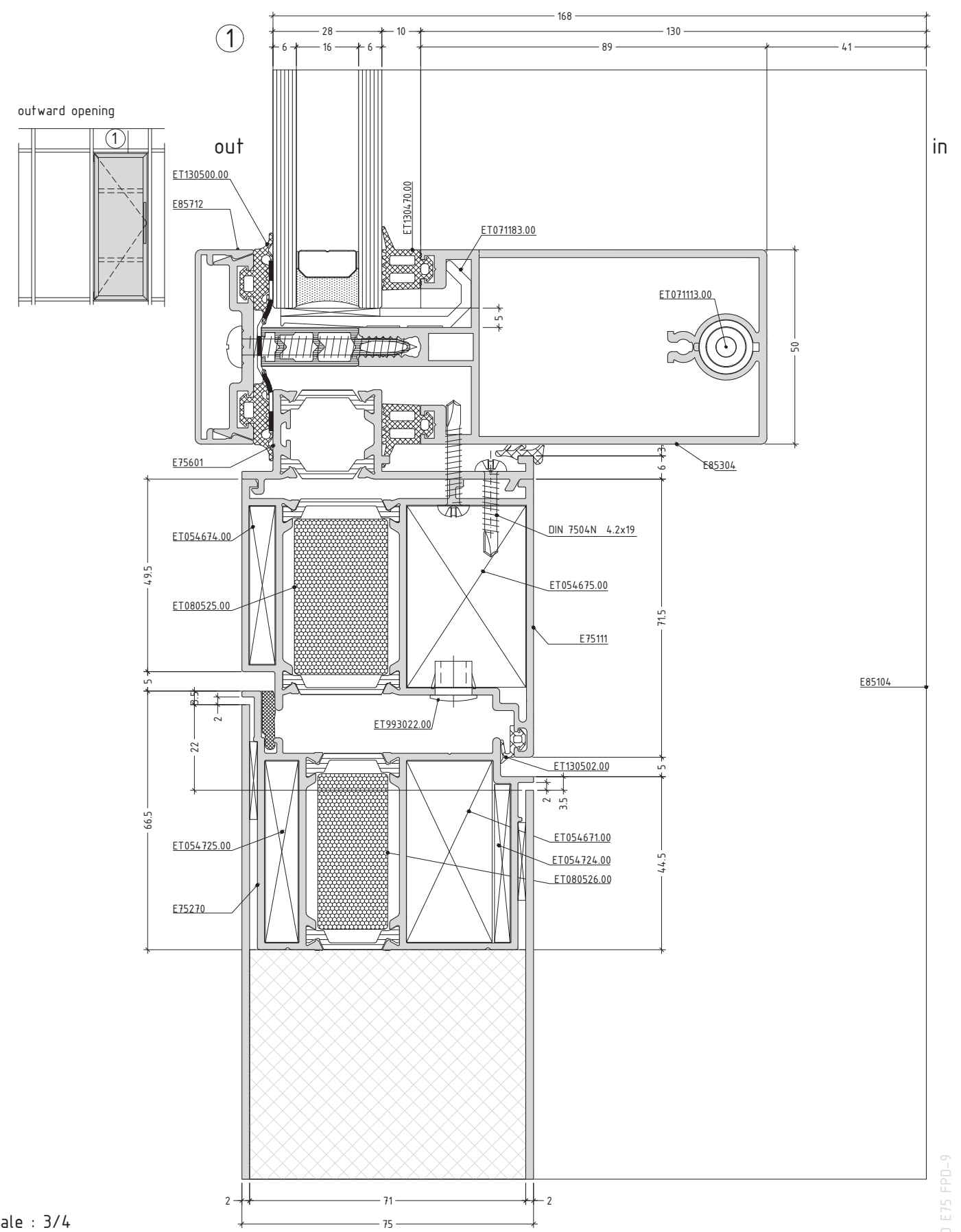

scale : 3/4

D E75 FPD-9







flat panel door system with thermal break

E75FPD

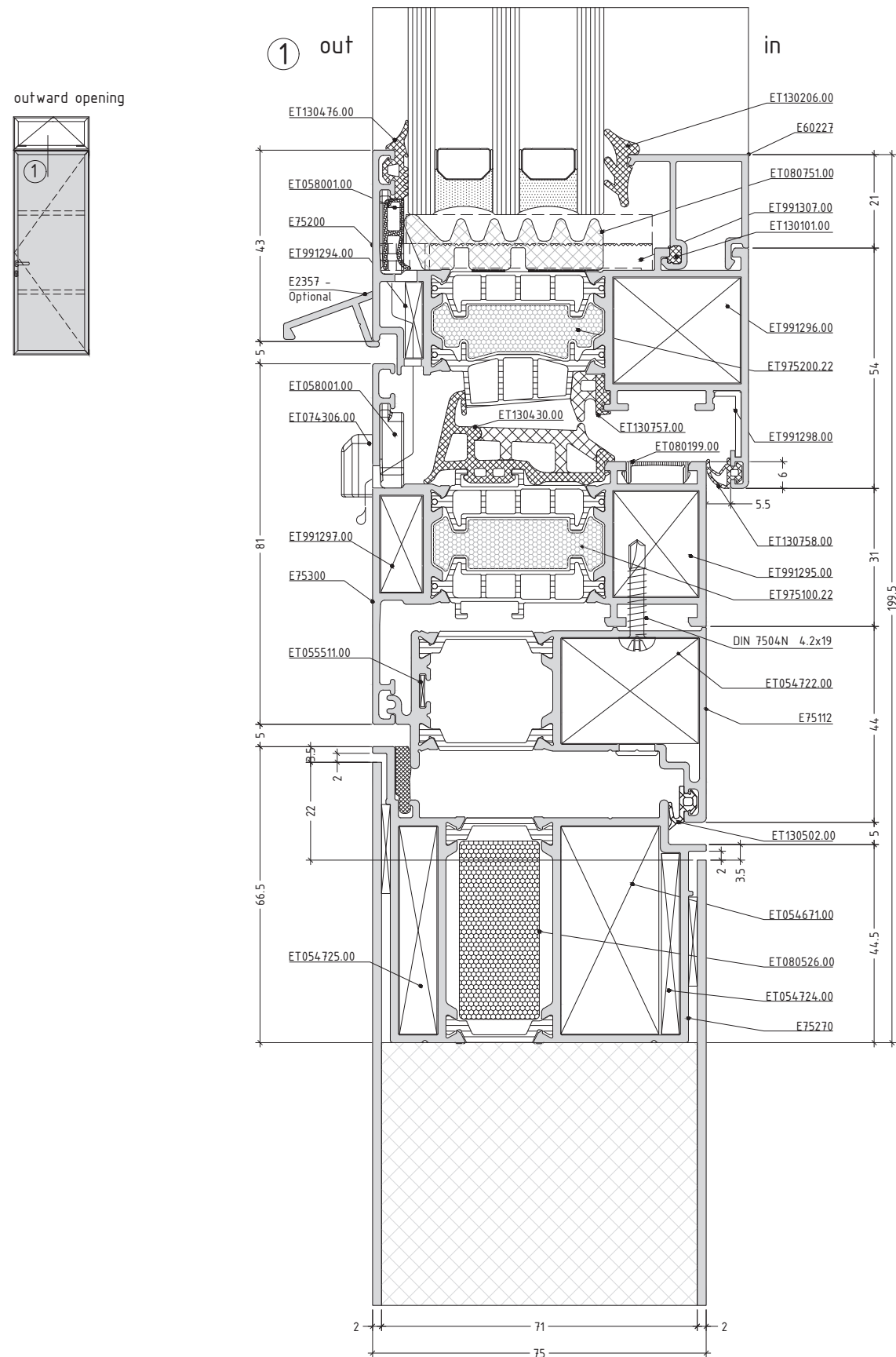

scale : 3/4

D E75 FPD-16

flat panel door system with thermal break

E75FPD

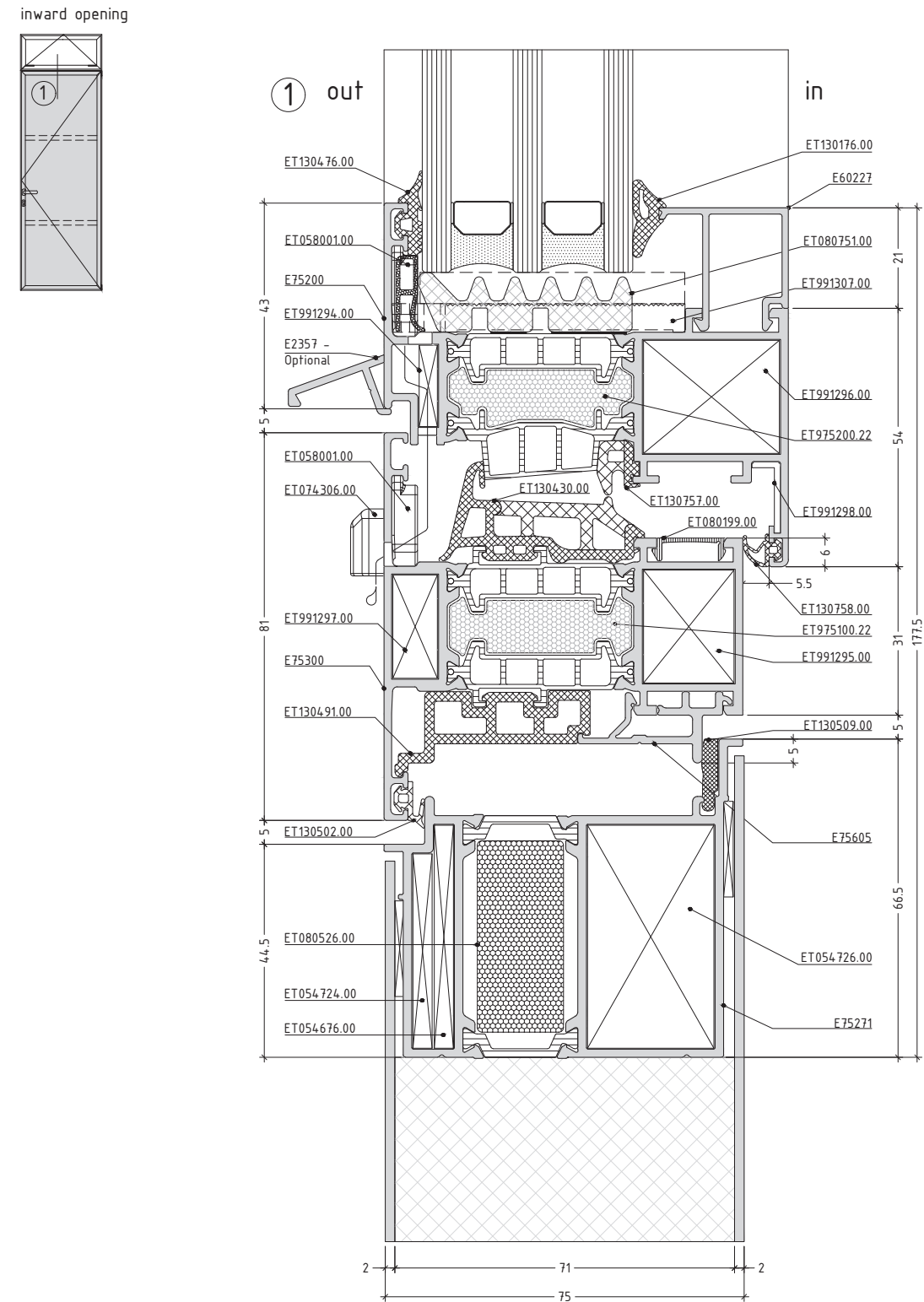

scale : 3/4

D E75 FPD-17

# CUTTING LISTS & MACHINING





outward opening - single sash door

		calculation of cutting length for one sash door		
profile selection		pieces	cutting formula	cutting angles
profile selection				
E75111 frame-outward 	width of frame	1	W	2x45°
	height of frame-left	1	H	1x45° up + 1x90° down
	height of frame-right	1	H	1x45° up + 1x90° down
E75270 sash-outward 	width of sash-outward	2	W - 109	2x45°
	height of sash-outward	2	H - 61.5	2x45°
E75372 T-profile 	width of T-profile	2	W - 244	2x90°
option 1				
E75810 or E75811 	width of door threshold	1	W - 143	2x90°
E75802 bottom rail 	width of bottom rail	1	width of sash-32	2x90°
option 2				
E75800 bottom rail optional finish 	width of bottom rail	1	width of sash-48	2x90°

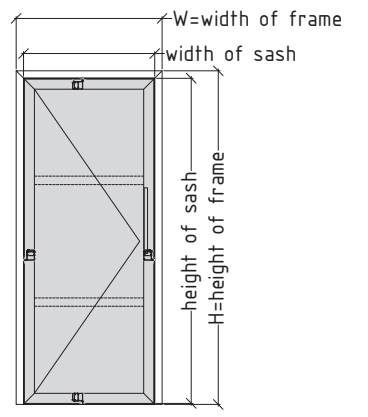
not to scale

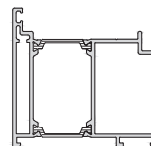
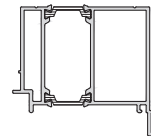
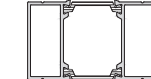
inward opening - single sash door



profile selection		pieces	cutting formula	cutting angles
E75110 	width of frame	1	W	2x45°
	height of frame-left	1	H	1x45° up + 1x90° down
	height of frame-right	1	H	1x45° up + 1x90° down
E75271 	width of sash-outward	2	W - 109	2x45°
	height of sash-outward	2	H - 615	2x45°
E75372 	width of T-profile	2	W - 244	2x90°
option 1				
E75810 or E75811 	width of door threshold	1	W - 143	2x90°
E75802 	width of bottom rail	1	width of sash-32	2x90°
option 2				
E75800 optional finish 	width of bottom rail	1	width of sash-48	2x90°
E75805 optional finish 	width of door threshold	1	W - 125	2x90°

not to scale

M E75 FPD-3

Calculation of cutting length for panel's sheet for one leaf doors with four side sash profile

Option with four side sash profile - E75270/E75271

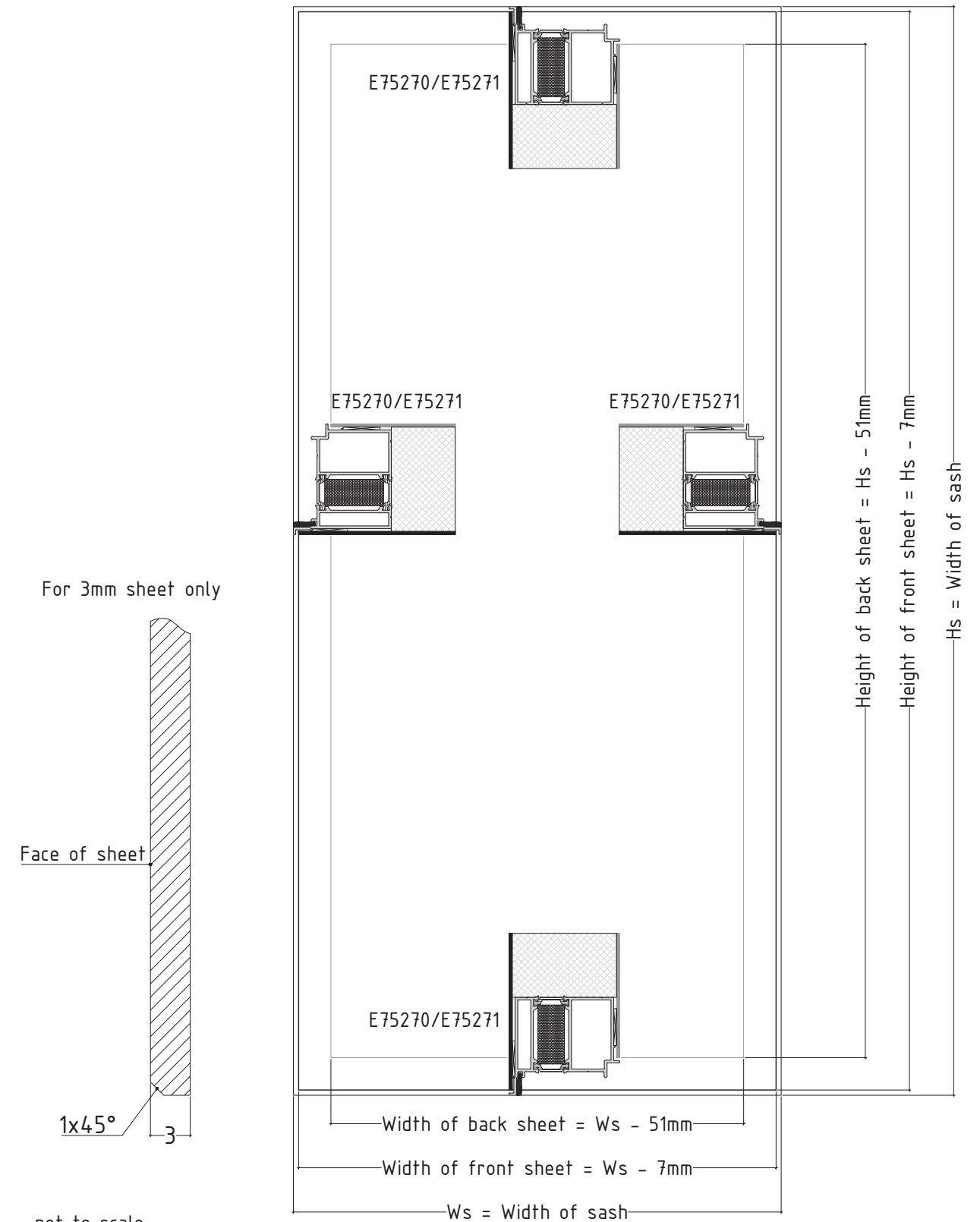

M E75 FPD-5

Dimension shown below is valid for locking hardware GU.238893.00

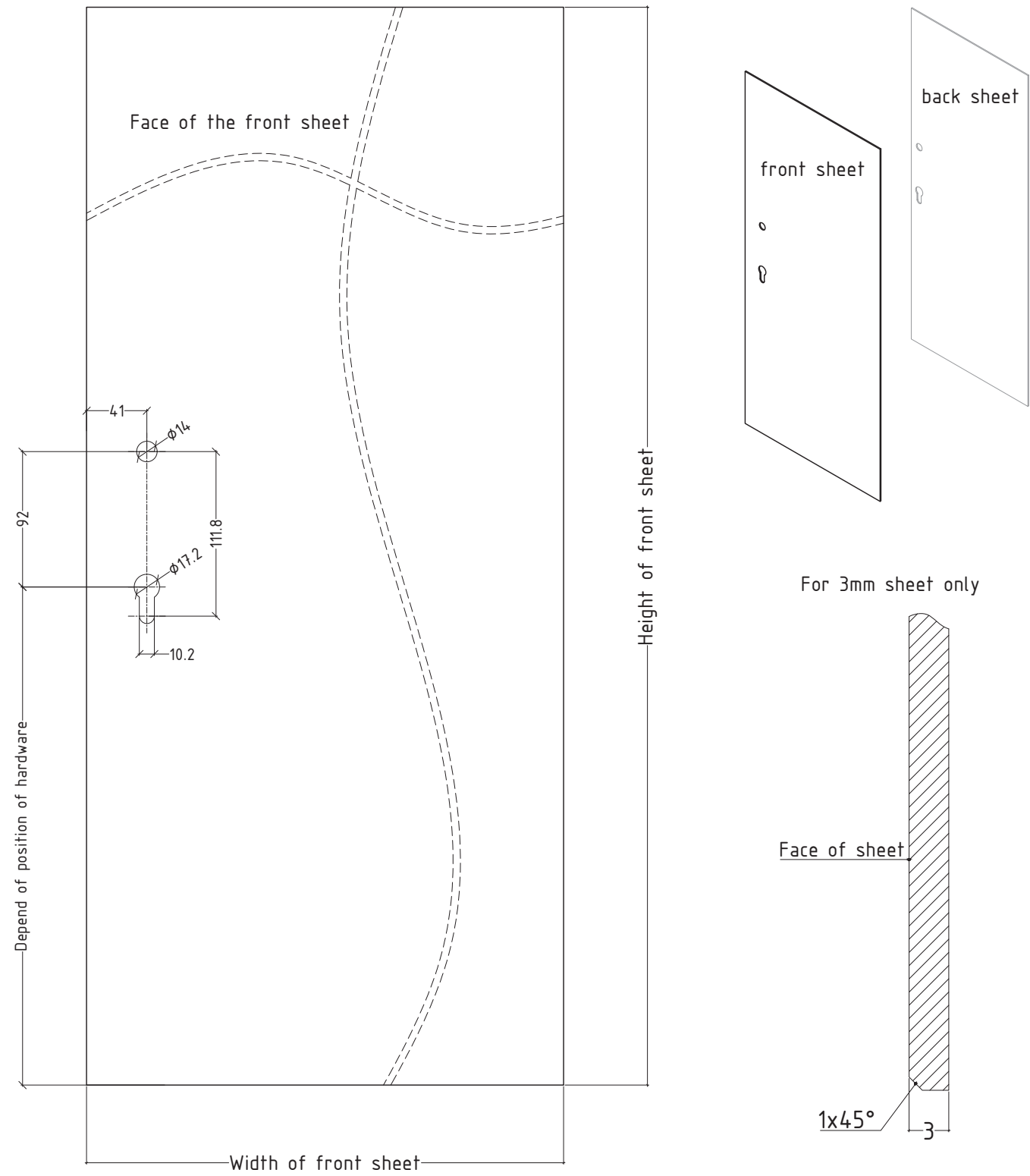

not to scale

M E75 FPD-5-2

Dimension shown below is valid for locking hardware GU.238893.00

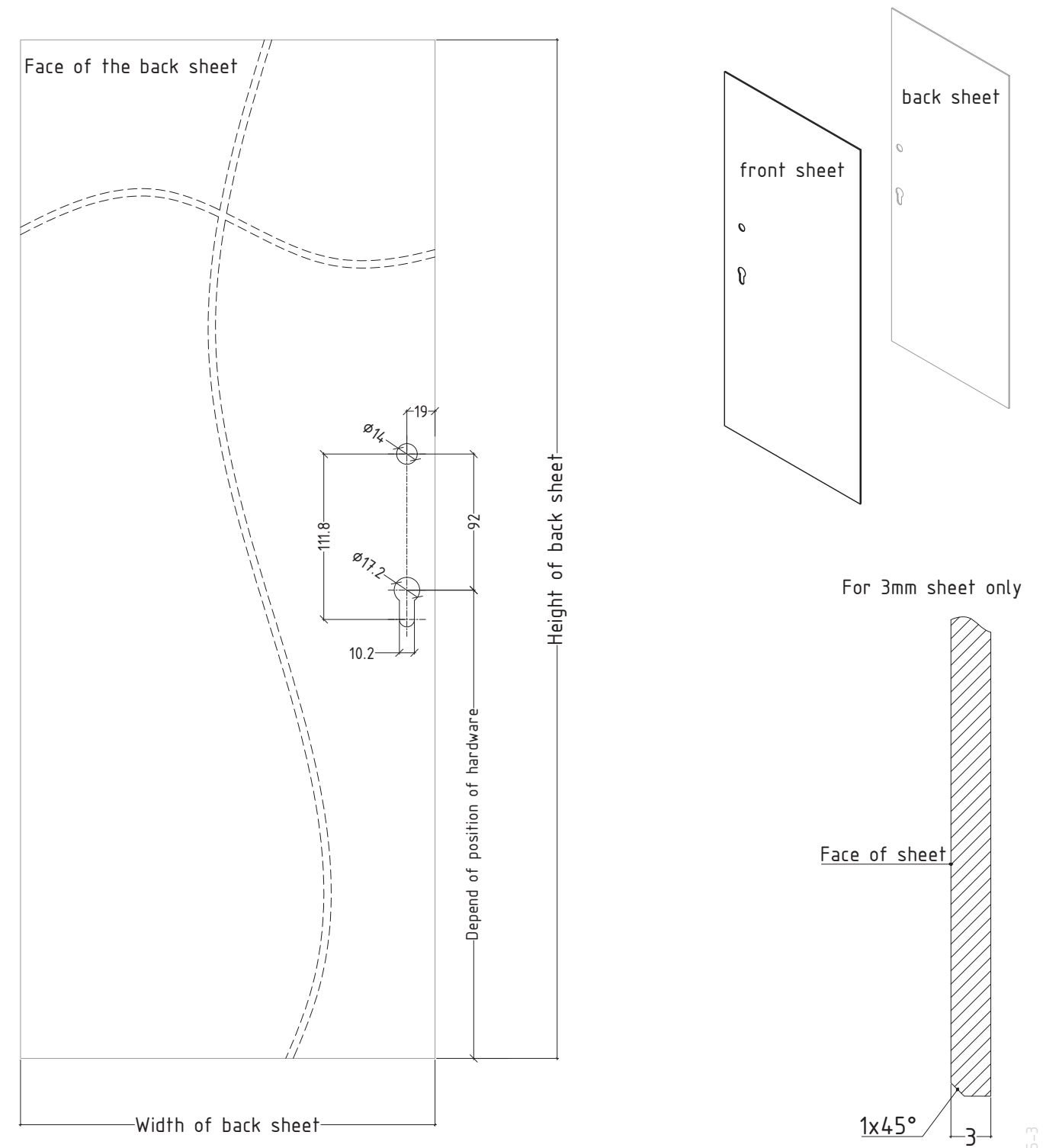

not to scale

M E75 FPD-5-3

outward opening - double sash door

		calculation of cutting length for two sash door		
profile selection		pieces	cutting formula	cutting angles
E75111 	width of frame	1	W	2x45°
	height of frame-left	1	H	1x45° + 1x90° up down
	height of frame-right	1	H	1x45° + 1x90° up down
E75270 	width of sash-outward	4	$\frac{W - 94}{2}$	2x45°
	height of sash-outward	2 + 1	H - 61.5	2x45°
E75271 	height of sash-inward	1	H - 61.5	2x45°
E75372 	width of T-profile	4	$\frac{W - 364}{2}$	2x90°
option 1				
E75810 or E75811 	width of door threshold	1	W - 143	2x90°
E75802 	width of bottom rail	2	width of sash-32	2x90°
option 2				
E75800 	width of bottom rail	1	width of sash-48 for active sash	2x90°
	width of bottom rail	1	width of sash-42 for passive sash	2x90°
E75805 	width of door threshold	1	W - 125	2x90°

not to scale

M E75 FPD-7

inward opening - double sash door

		calculation of cutting length for two sash door		
profile selection		pieces	cutting formula	cutting angles
E75110 	width of frame	1	W	2x45°
	height of frame-left	1	H	1x45° + 1x90° up down
	height of frame-right	1	H	1x45° + 1x90° up down
E75271 	width of sash-outward	4	$\frac{W - 94}{2}$	2x45°
	height of sash-outward	2 + 1	H - 61.5	2x45°
E75270 	height of sash-inward	1	H - 61.5	2x45°
E75372 	width of T-profile	4	$\frac{W - 364}{2}$	2x90°
option 1				
E75810 or E75811 	width of door threshold	1	W - 143	2x90°
E75802 	width of bottom rail	2	width of sash-32	2x90°
option 2				
E75800 	width of bottom rail	1	width of sash-48 for active sash	2x90°
	width of bottom rail	1	width of sash-42 for passive sash	2x90°
E75805 	width of door threshold	1	W - 125	2x90°

not to scale

M E75 FPD-9

outward opening double sash door

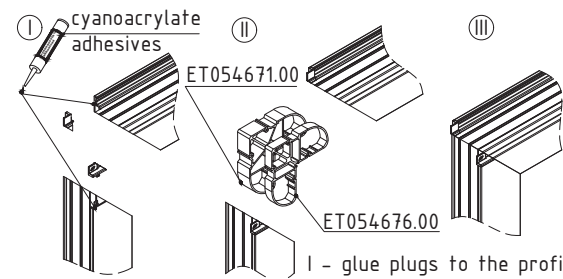
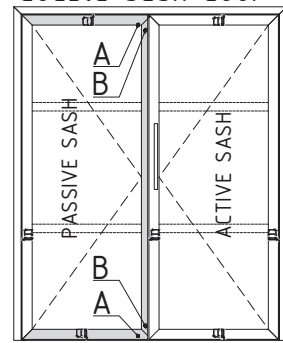

Sequence of assembly between sash-inward and sash-outward and specific joint corners usage

I - glue plugs to the profile  
 II - insert corner brackets in combination ET054671.00 + ET054676.00 for sash E75271 sash-inward + E75270 sash-outward  
 III - crimp profiles

Front view

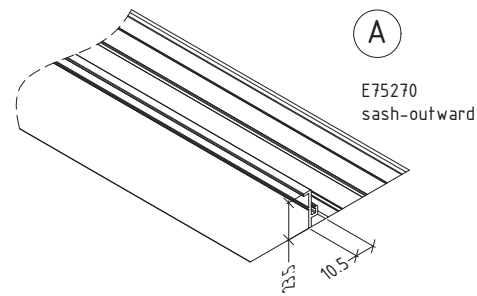

A E75270 sash-outward

Back view

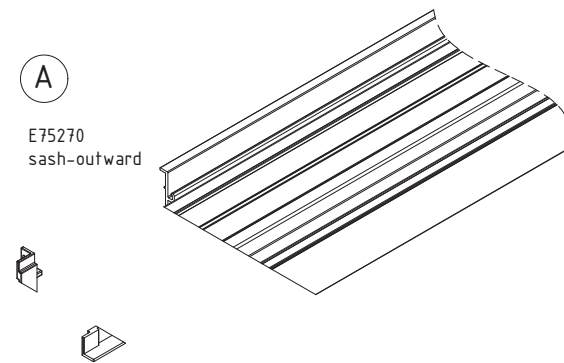

A E75270 sash-outward

B E75271 sash-inward

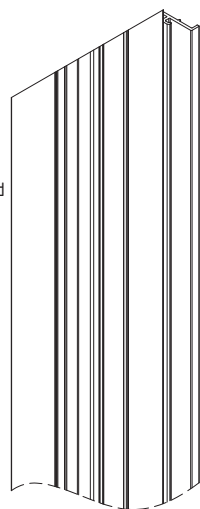

B E75271 sash-inward

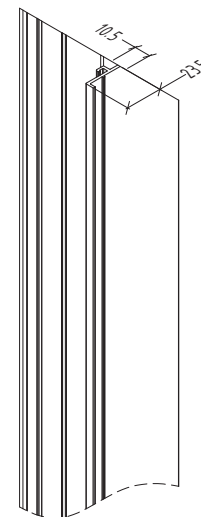

not to scale

M E75 FPD-11

outward opening double sash door

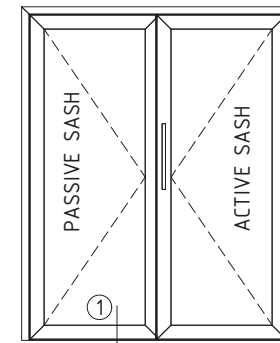

inward opening double sash door

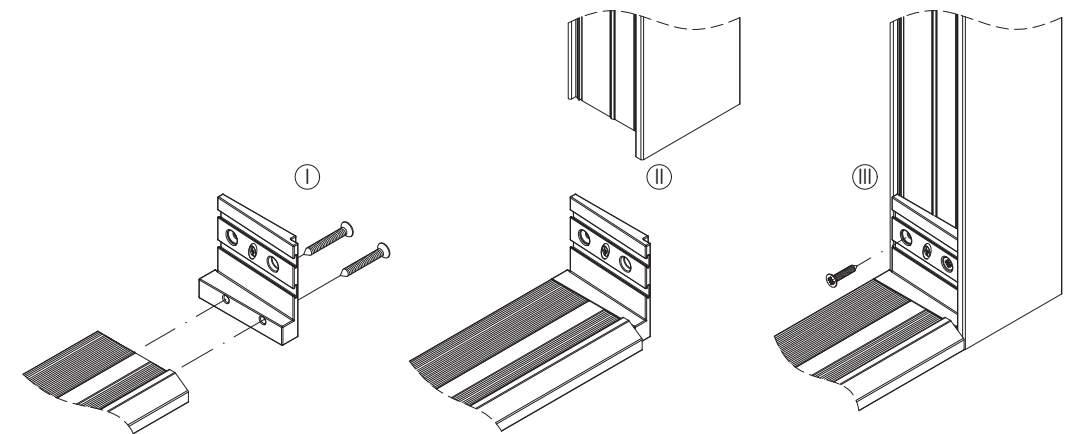
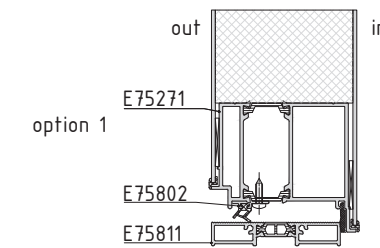
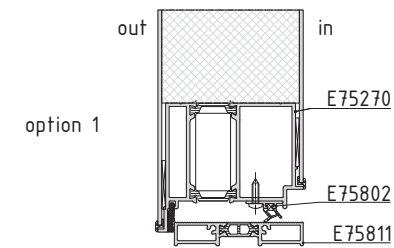
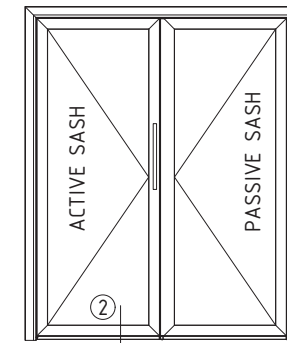

not to scale

M E75 FPD-13



machining required on E75270 for lock

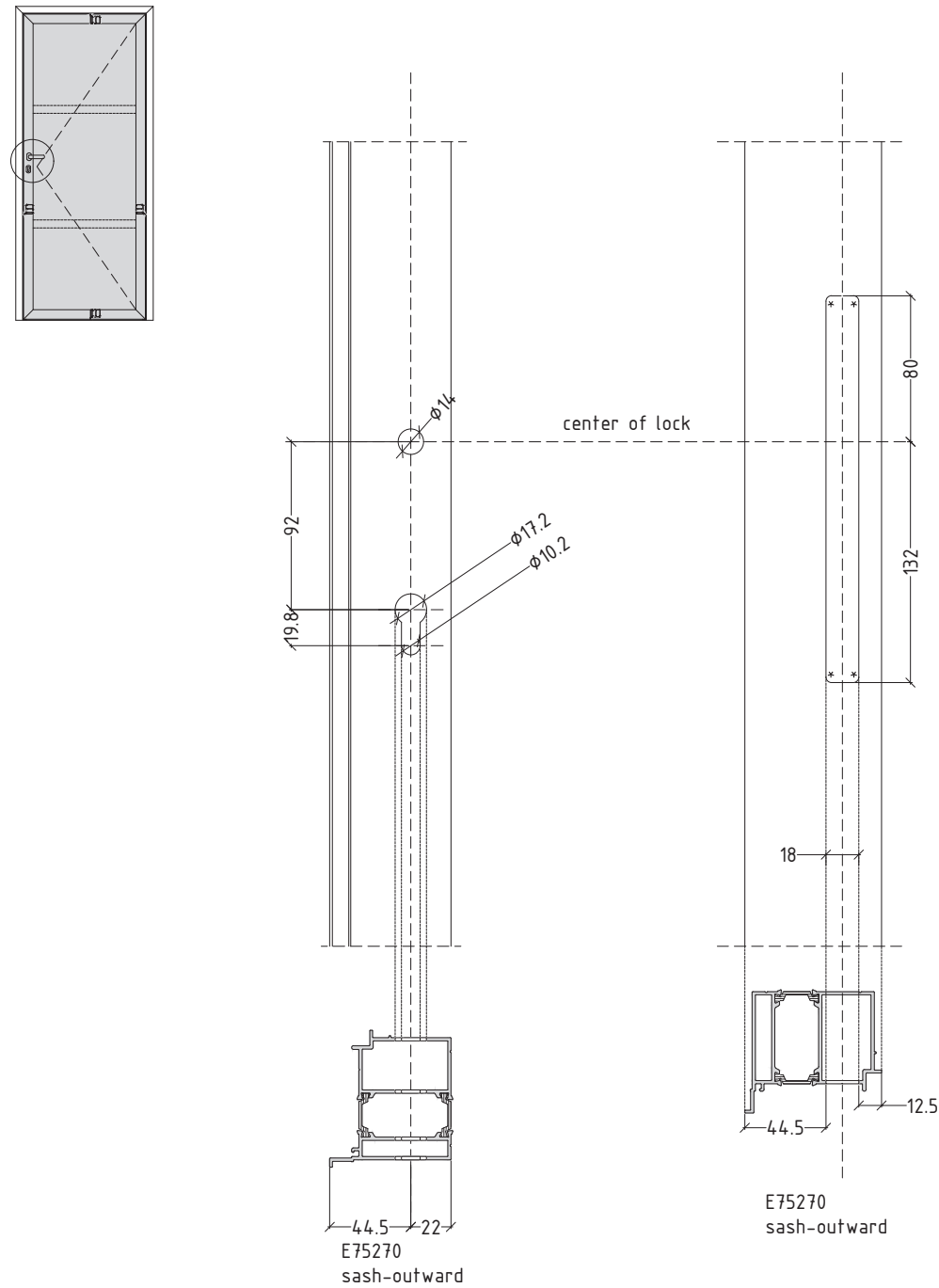

\* The dimensions refer to anodized and mill-finished profiles!  
For powder coated profiles, the thickness of the coating must be taken into account!  
not to scale

\*  
R=3mm

M E75 FPD-14

machining required on E75111 & E75270 for lock

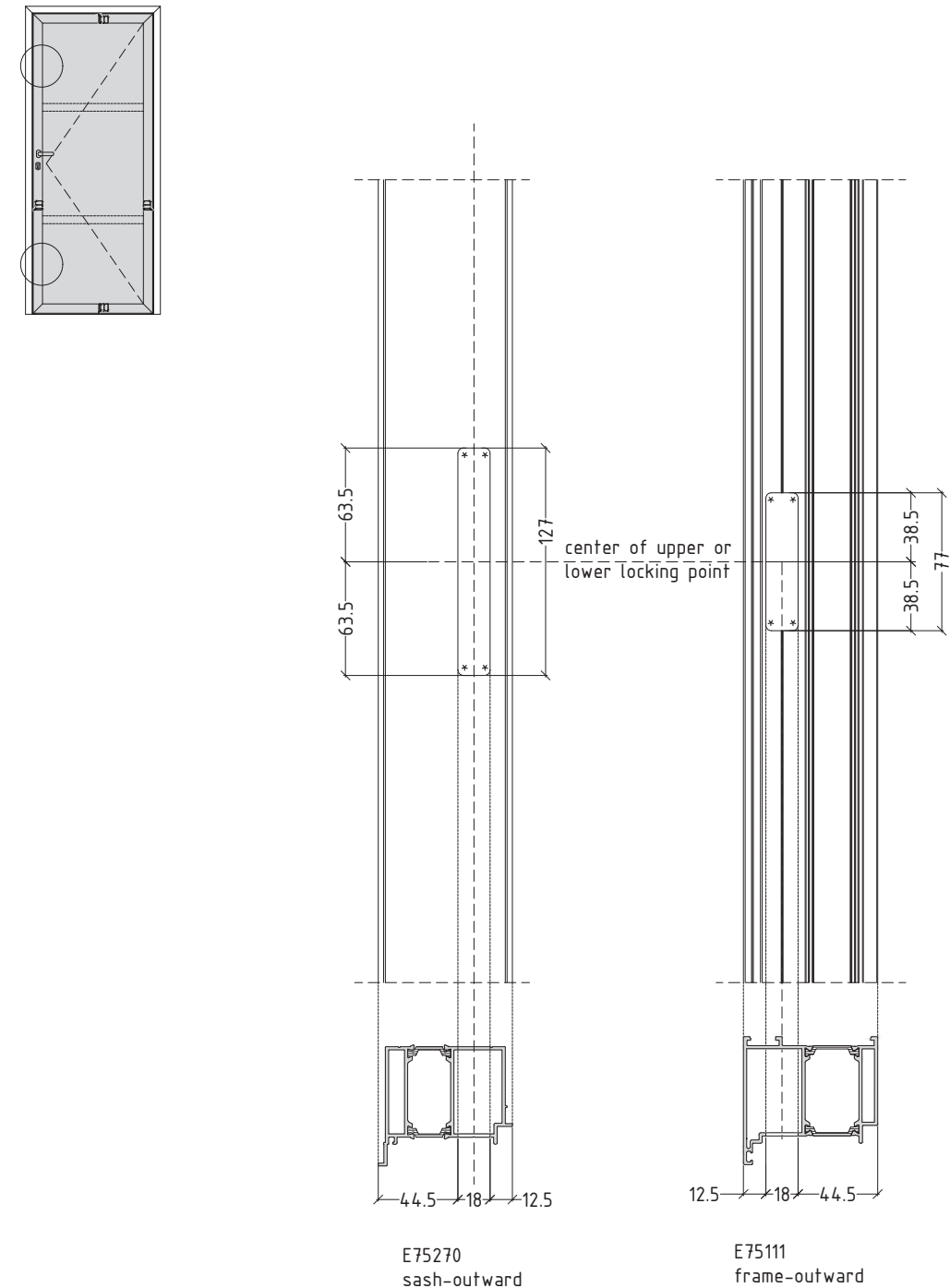

\* The dimensions refer to anodized and mill-finished profiles!  
For powder coated profiles, the thickness of the coating must be taken into account!  
not to scale

\*  
R=3mm

M E75 FPD-15

flat panel door system with thermal break

E75FPD

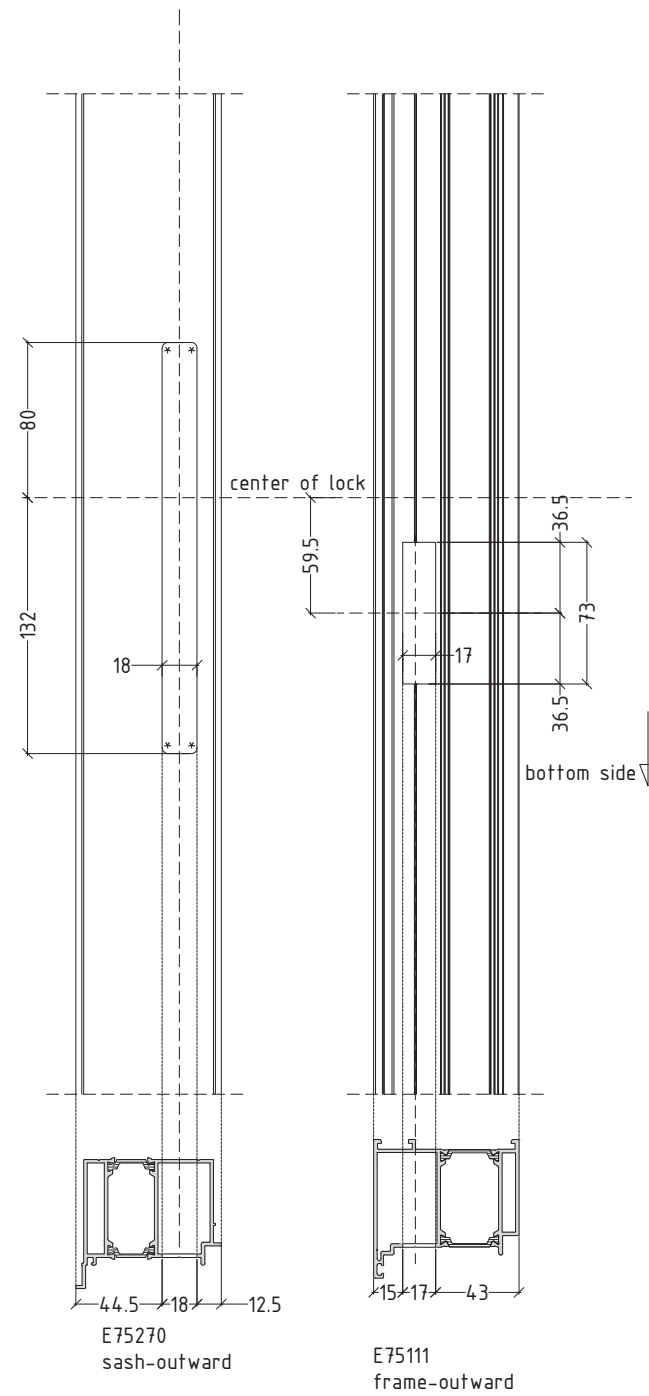
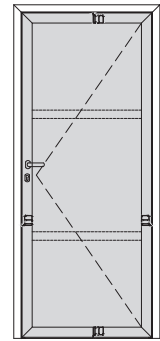

\* The dimensions refer to anodized and mill-finished profiles!

For powder coated profiles, the thickness of the coating must be taken into account!

not to scale

\* R=3mm

M E75 FPD-16

flat panel door system with thermal break

E75FPD

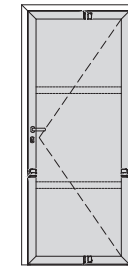

machining required on E75111 & E75270 for lock

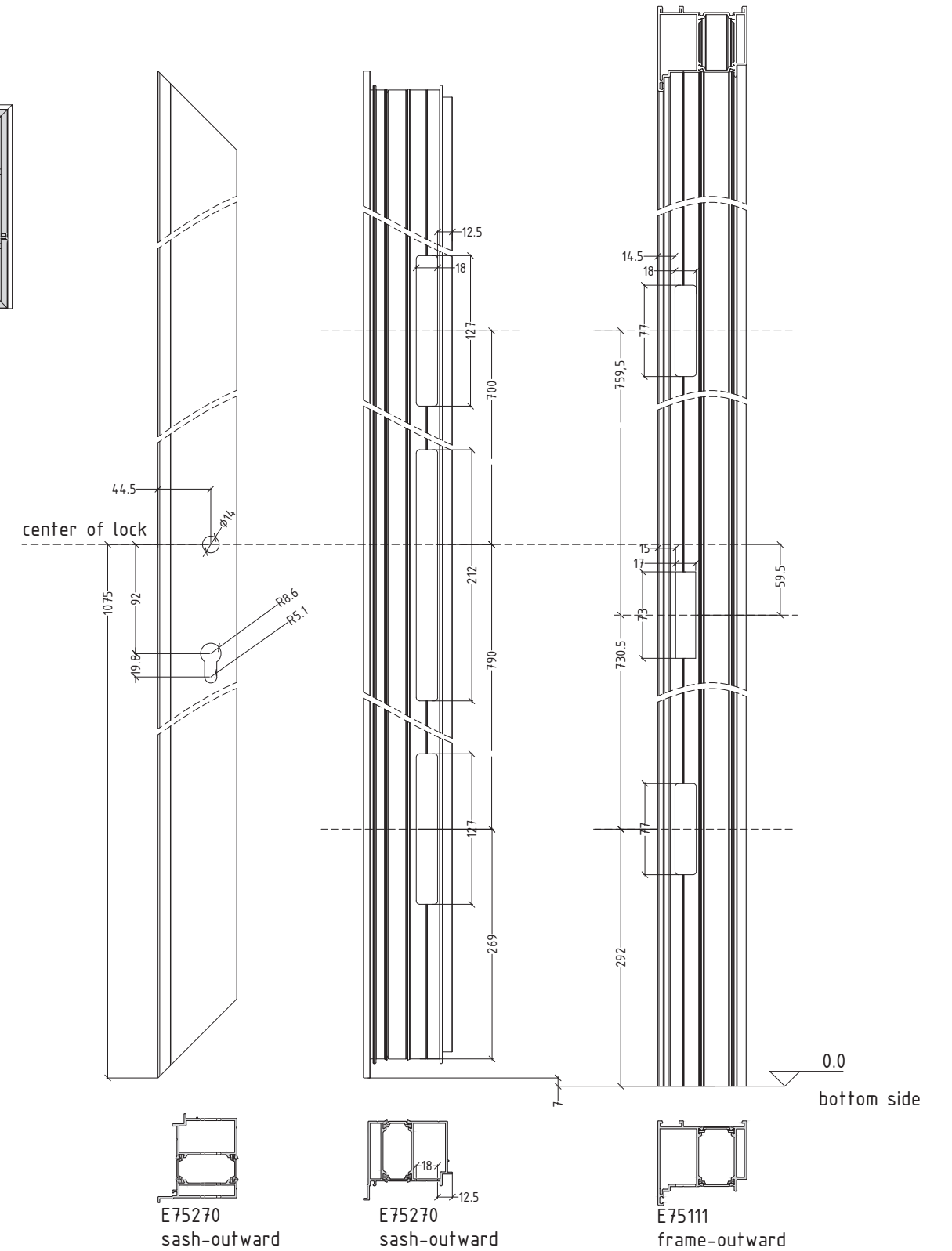

\* The dimensions refer to anodized and mill-finished profiles!

For powder coated profiles, the thickness of the coating must be taken into account!

not to scale

M E75 FPD-17

flat panel door system with thermal break

E75FPD

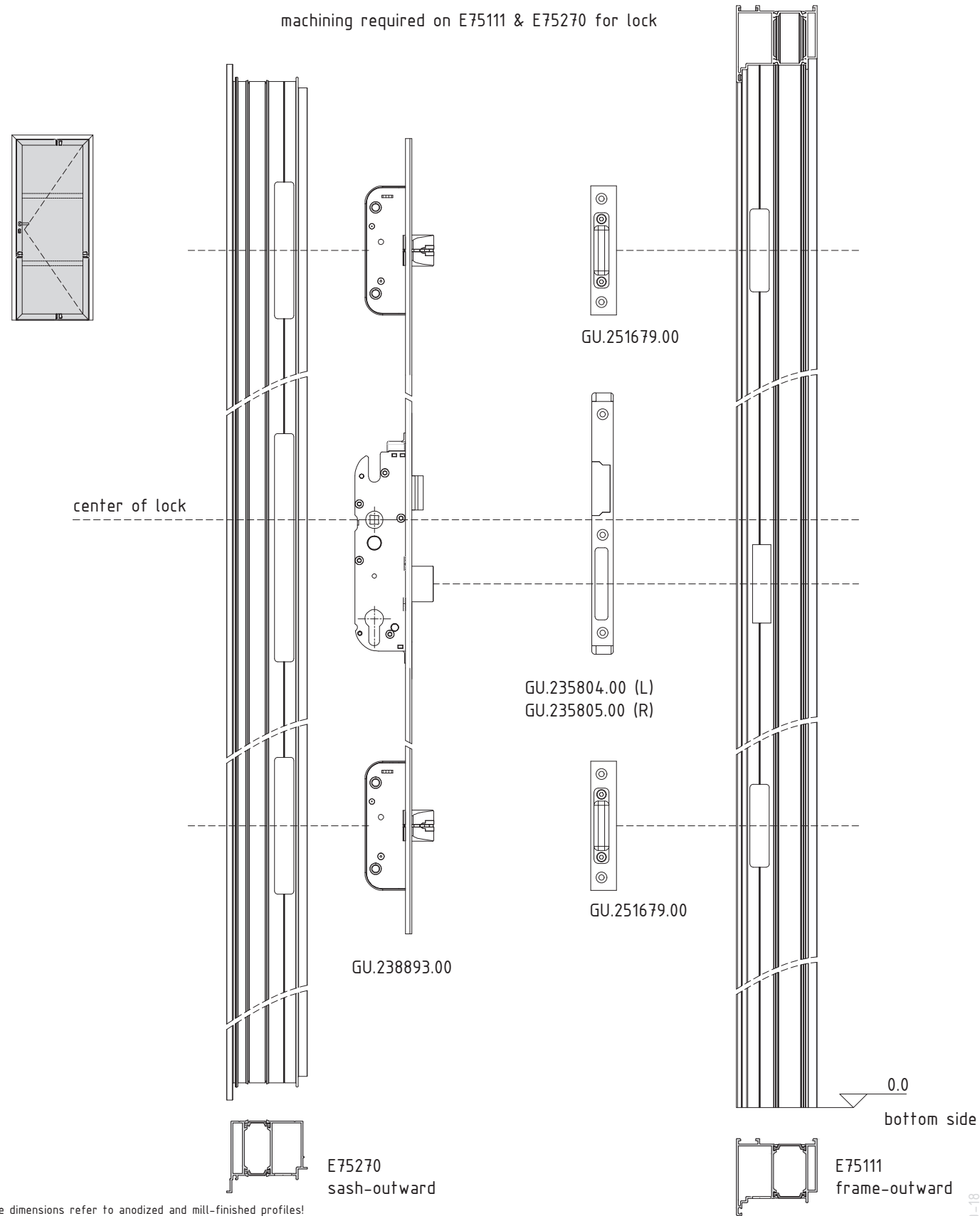

\* The dimensions refer to anodized and mill-finished profiles!

For powder coated profiles, the thickness of the coating must be taken into account!

not to scale

M E75 FPD-18

flat panel door system with thermal break

E75FPD

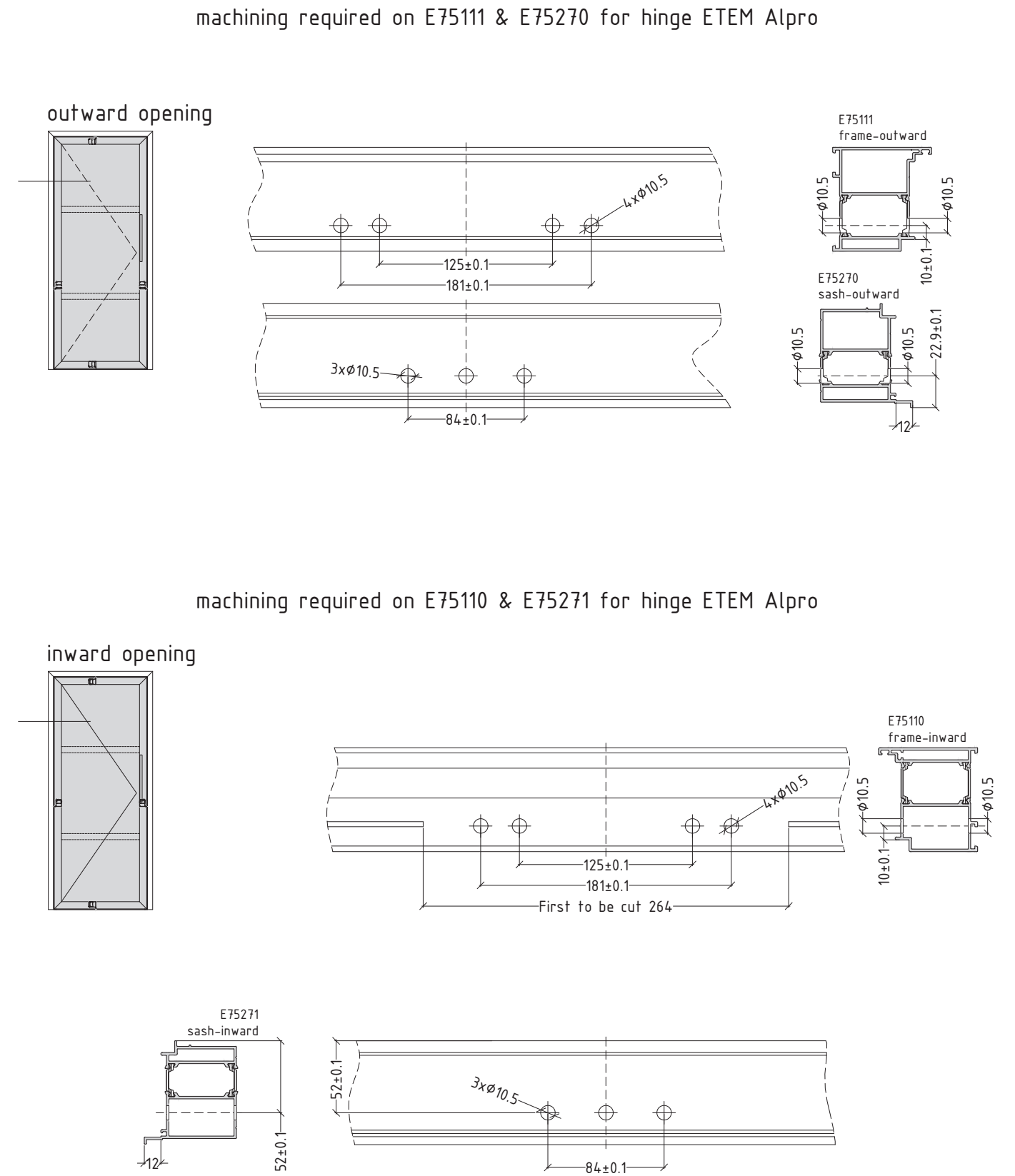

not to scale

M E75 FPD-19

flat panel door system with thermal break

E75FPD

machining required on E75111 & E75270 for box locking parts on hinge side GU235812.00

outward opening

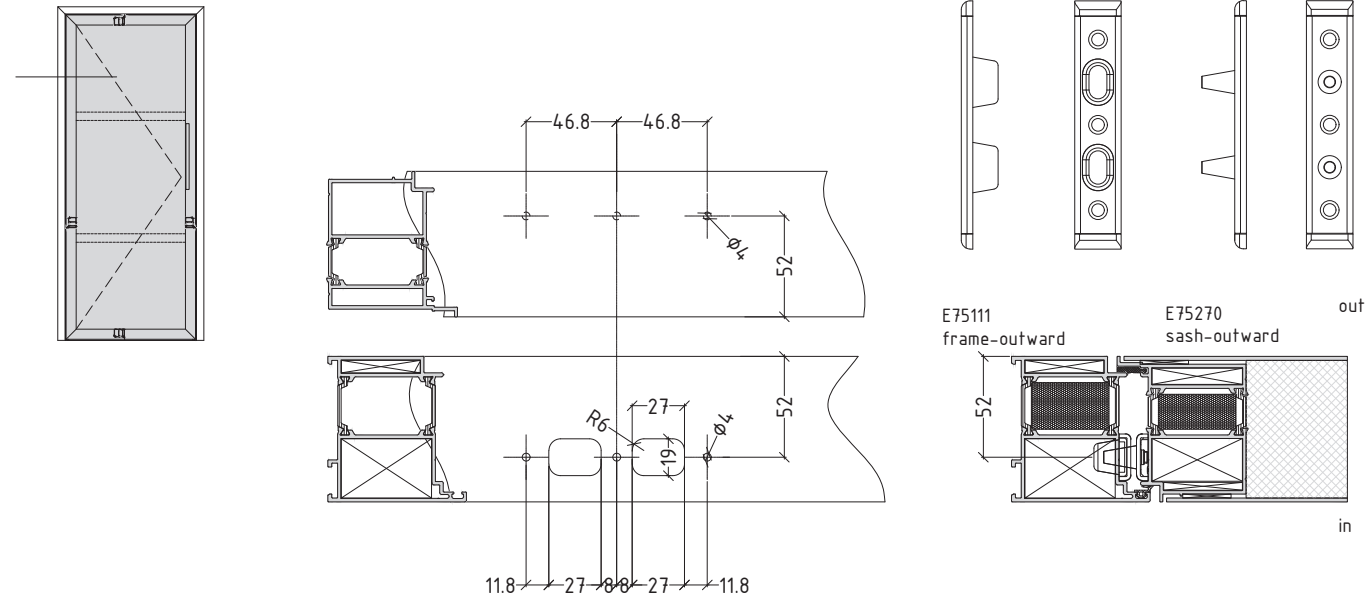

inward opening

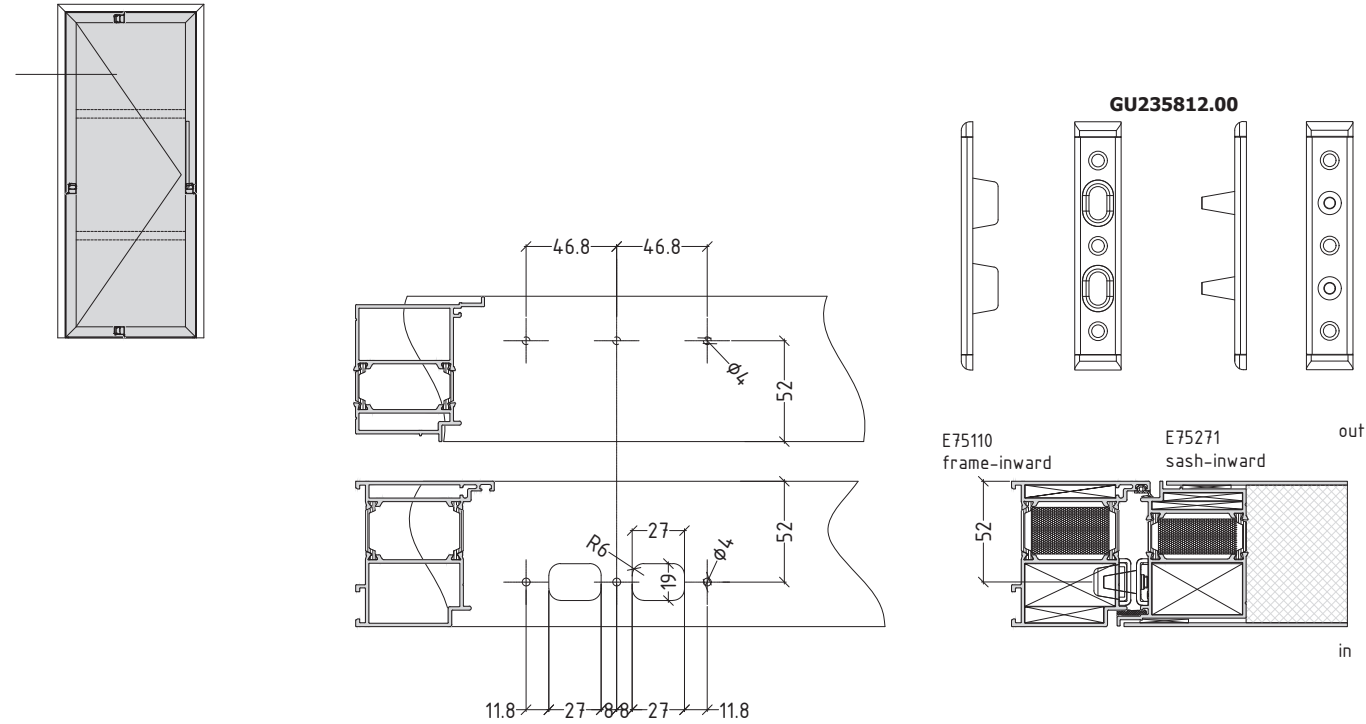

not to scale

M E75 FPD-19-1

flat panel door system with thermal break

E75FPD

sequence of assembly and adjustment for hinge ETEM Alpro

outward opening

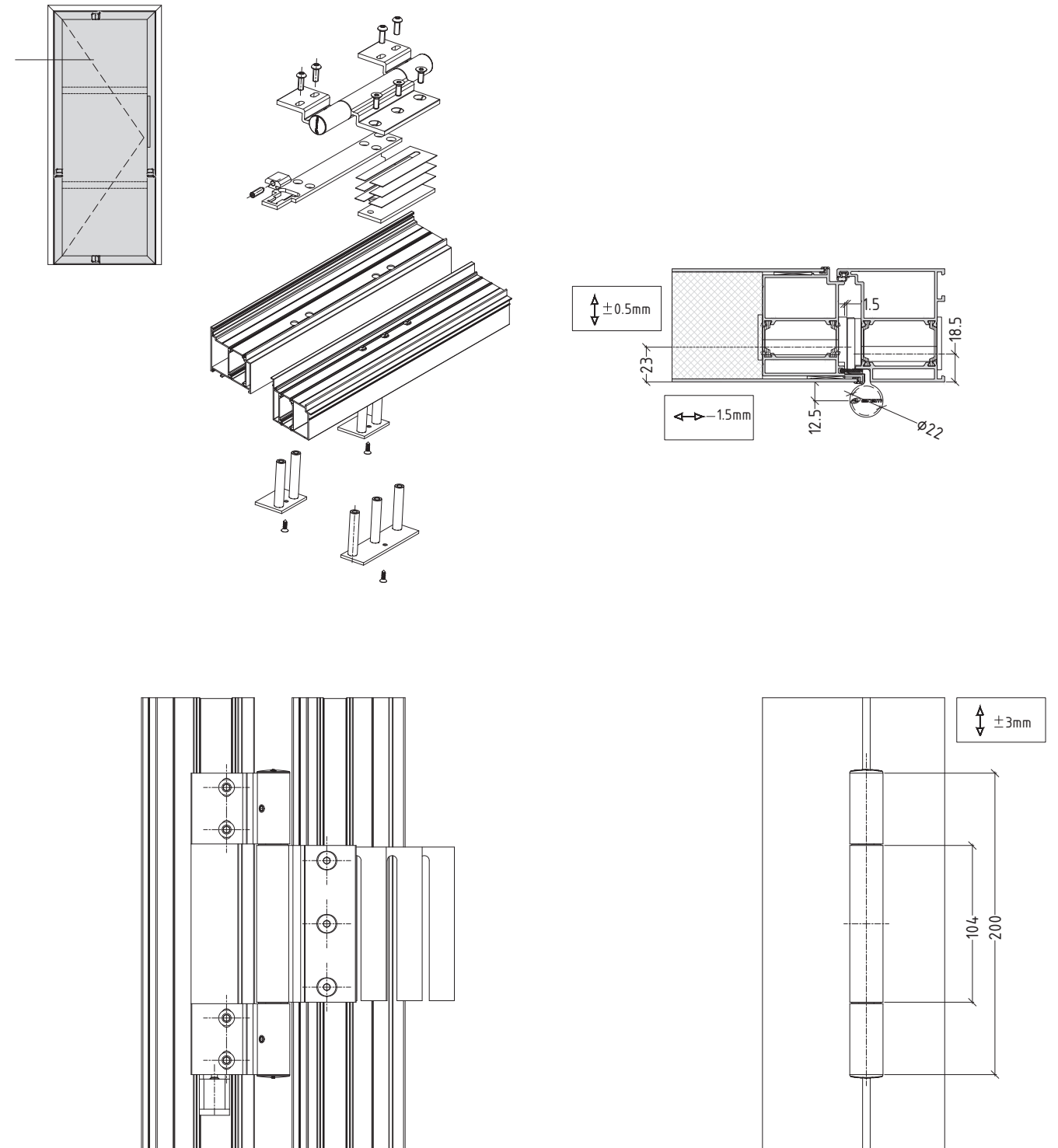

not to scale

M E75 FPD-20

machining required on frame E75111 and sash E75270 for hidden hinge Simonswerk TECTUS

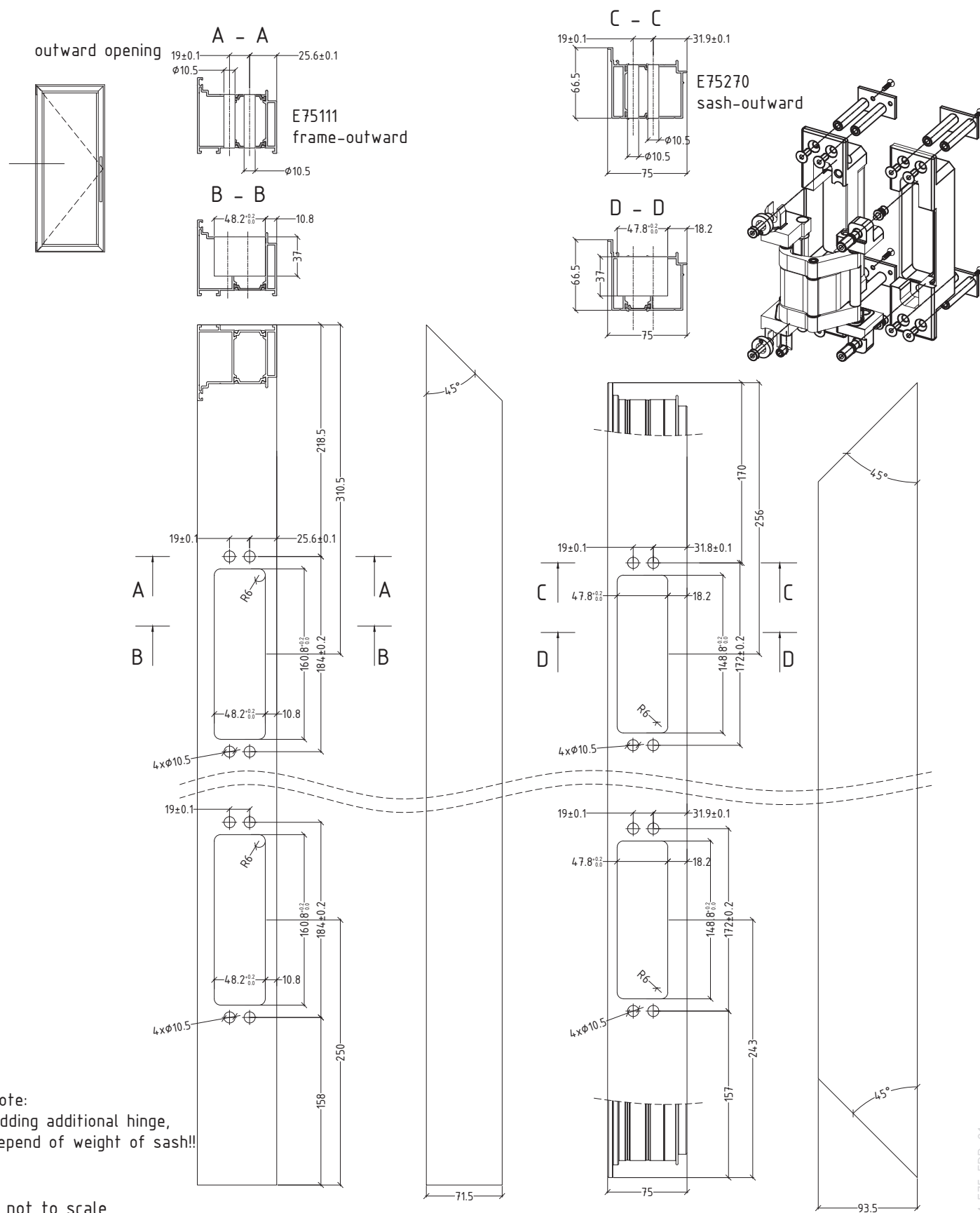

Note:  
Adding additional hinge,  
depend of weight of sash!!

not to scale

M E75 FPD-21

machining required on frame E75110 and sash E75210 for hidden hinge Simonswerk TECTUS

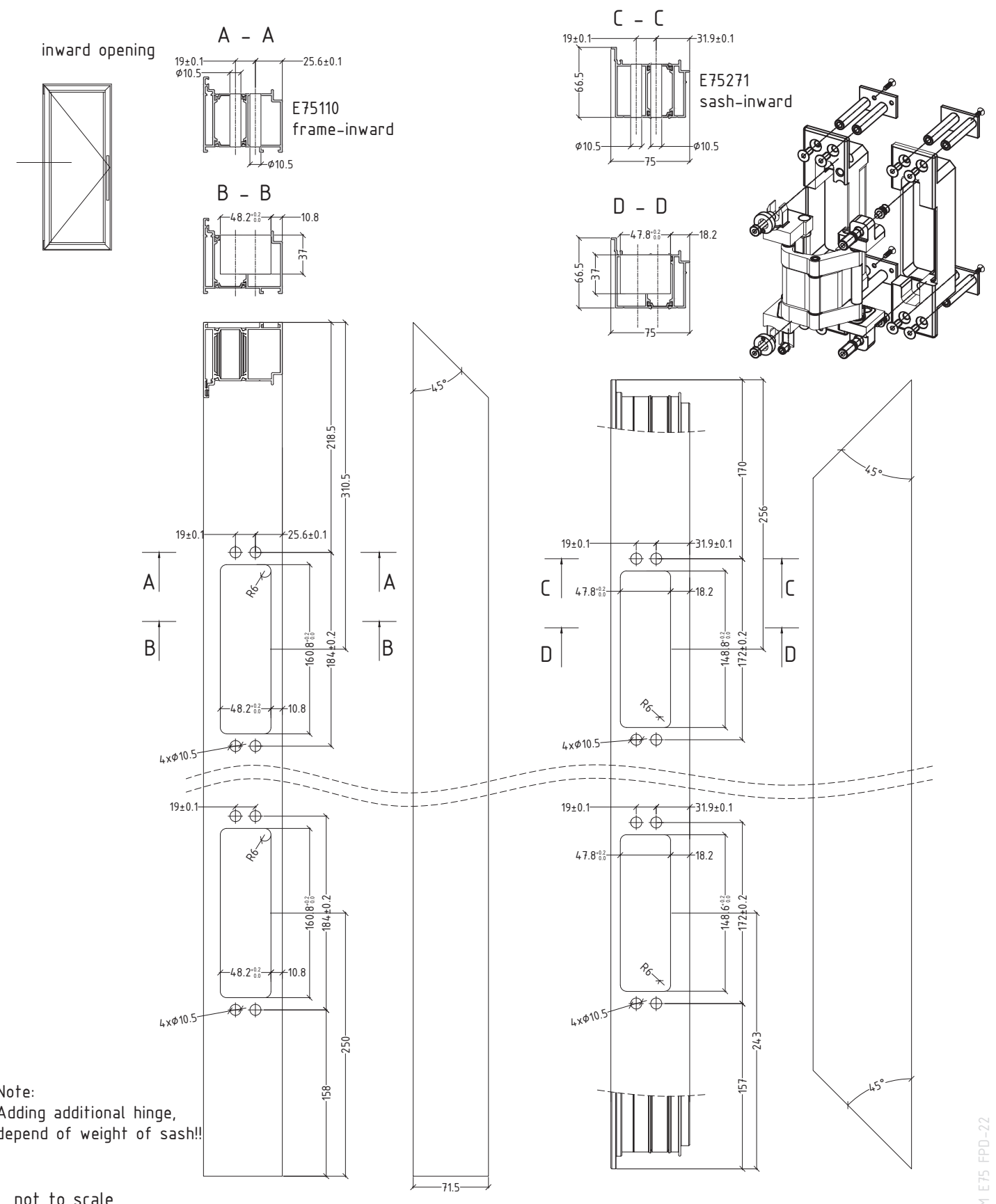

Note:  
Adding additional hinge,  
depend of weight of sash!!

not to scale

M E75 FPD-22

Additional treatment of profiles for ventilation

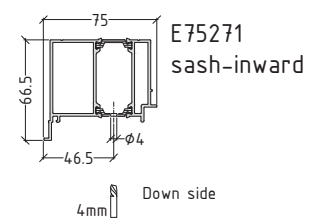
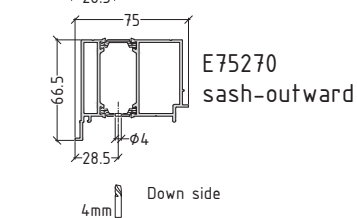
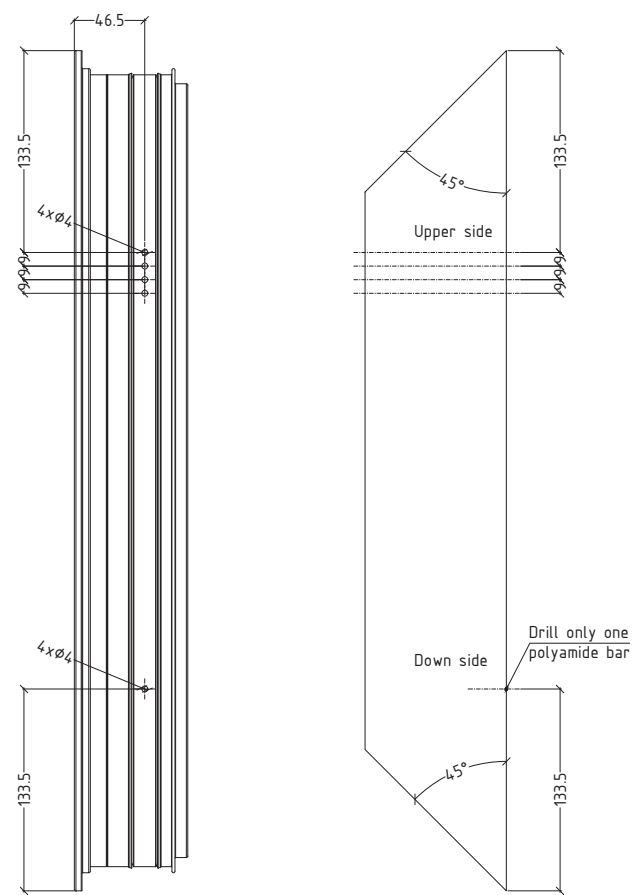
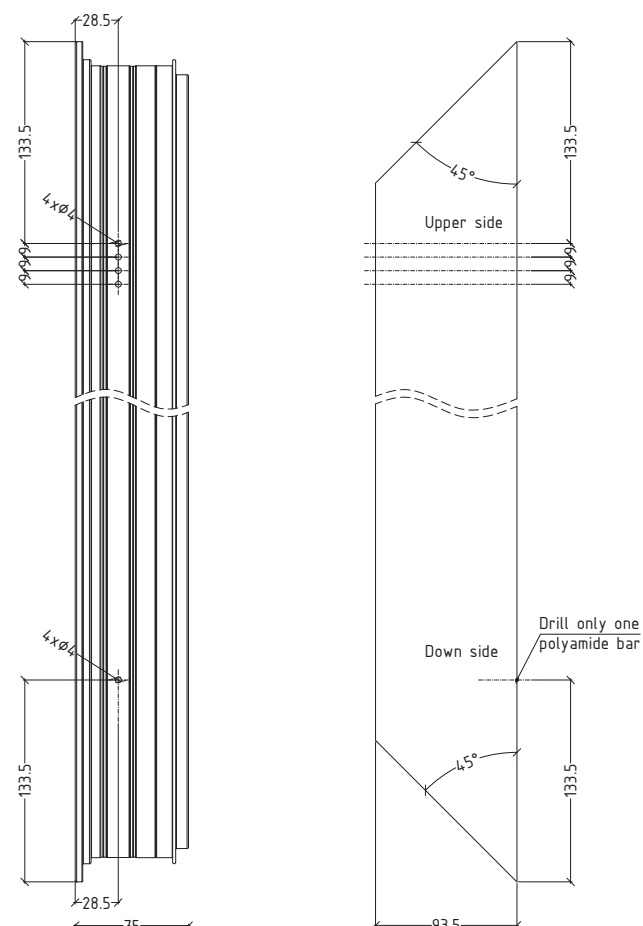
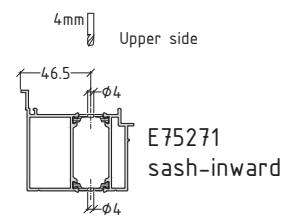
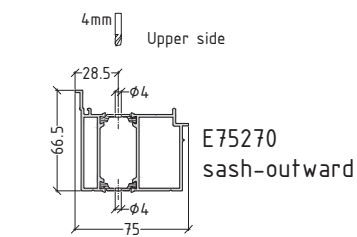
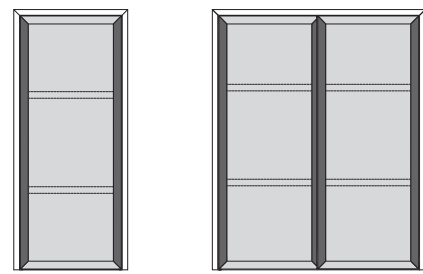

not to scale

M E75 FPD-23

Additional treatment of profiles for ventilation and drainage

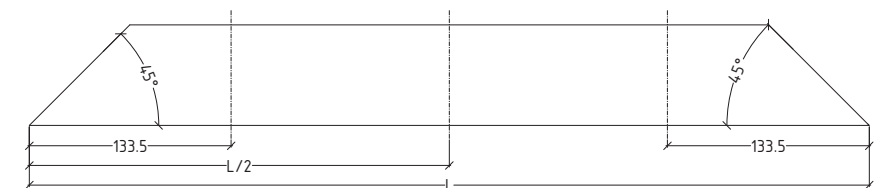
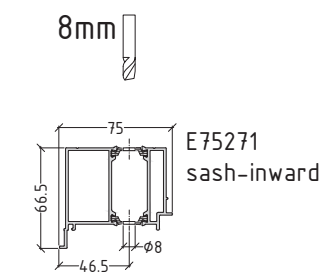
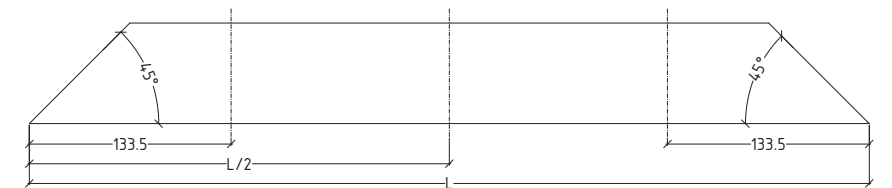
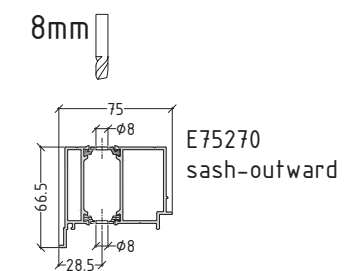
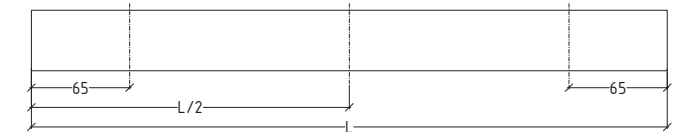
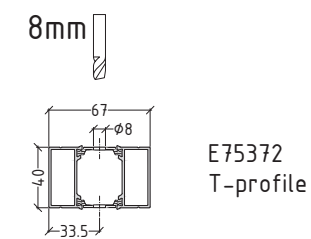
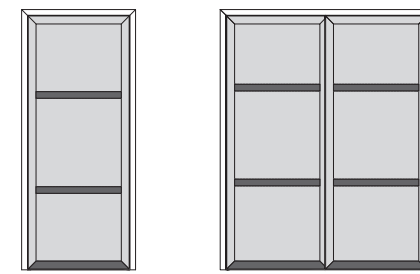

not to scale

M E75 FPD-24

MOUNTING SEQUENCE OF FLAT MATERIALS TO THE SASH OF FLAT PANEL DOOR

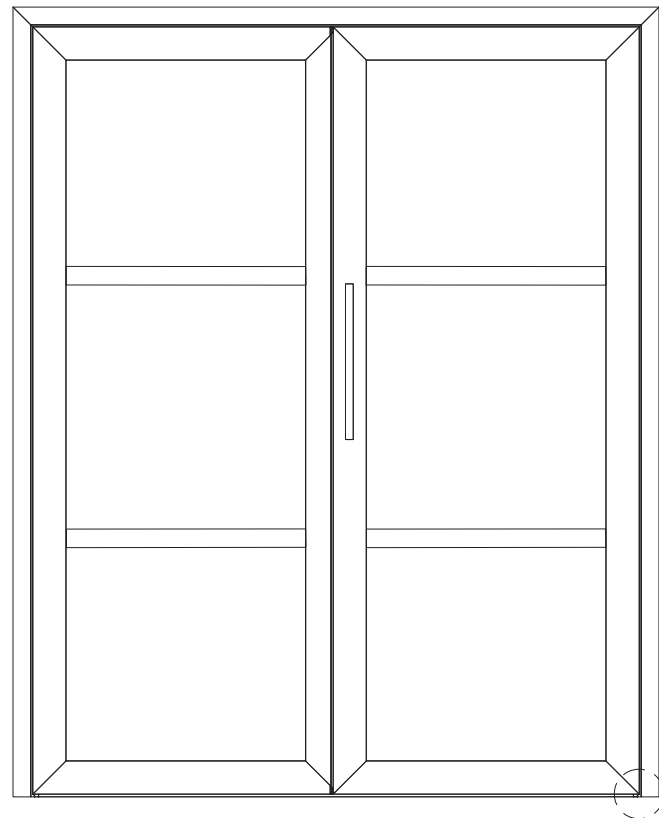

A. PREPARING THE PROFILE BEFORE PLACING THE FLAT MATERIAL

- 1 Spray the metal frame with 3M VHB Surface Cleaner. Wipe (in one direction) the 3M VHB Surface Cleaner off with a clean lint free towel.
- 2 Abrade with Scotch Brite 7447A-VFN.
- 3 Repeat step 1 and wait for the surface to dry.
- 4 Apply a primer ET994353.00 for better contact between the surface and the tape ET133504.00

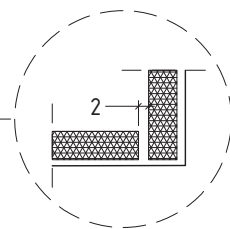

Connection of horizontal and vertical tape in the corner area

- 5 Apply tape ET133504.00 by hand or use VHB tape applicator Roll down tape ET133504.00 with roller. Check presence of air bubbles under the tape - and remove them
- 6 Remove partly the tape ET133504.00 protector layer. Full removal of the protector layer is performed after positioning of the flat material

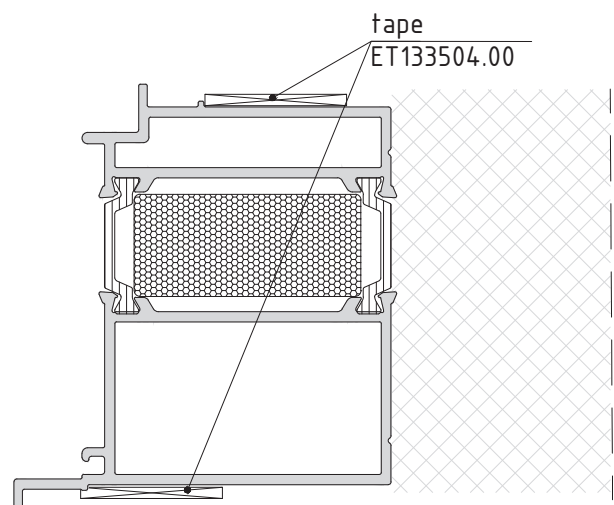
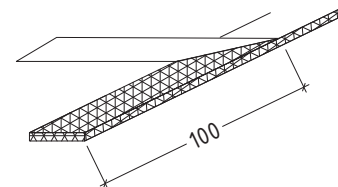

not to scale

M E75 FPD-25

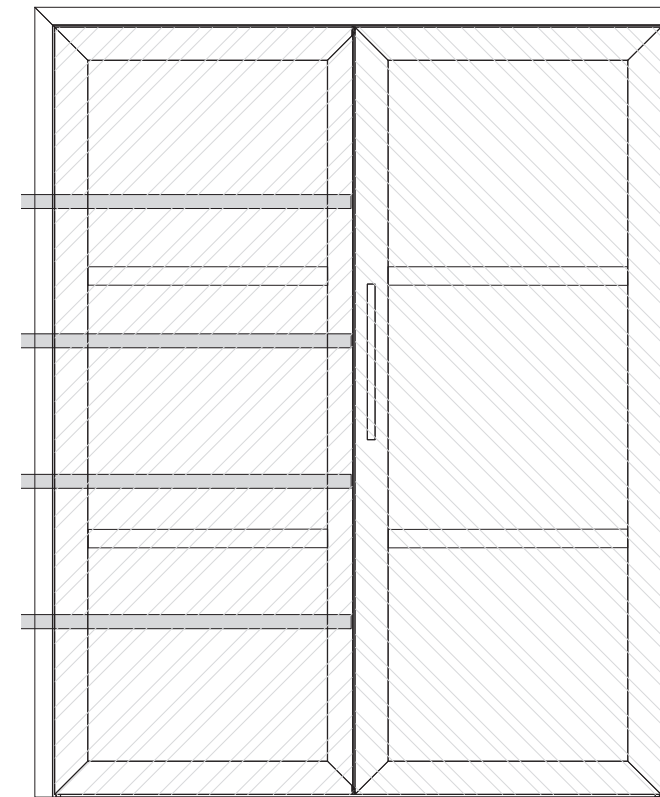

B. PREPARATION OF THE FLAT MATERIAL BEFORE INSTALLATION

- 7 Repeat steps 1,2,3,4 on the flat material surface in the bonding area.
- 8 It is recommended to place spacers for more precise positioning of the flat material to bonding.
- 9 Before placing the flat material, apply polyurethane glue that will be in contact with the insulation layer
- 10 Put the teflon tapes under the flat material in order to position properly the flat material before gluing. It is recommended vacuum lifter to be used.
- 12 Once the flat material has been laid, remove the protector of the tape ET133504.00, the spacer, and apply pressure (min 100 kPa) to the areas with the tape ET133504.00 for good adhesion.

Repeat the steps for mounting the flat material on all sides.

N.B. The thickness of the flat material used shall not exceed 2-3 mm.

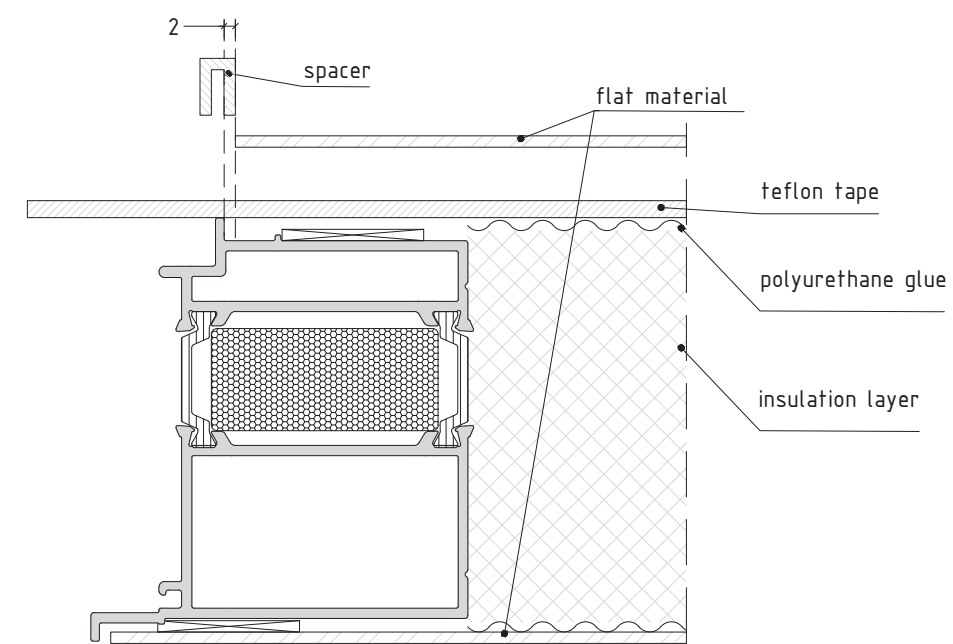

not to scale

N.B. The density of the insulating layer must be 100-125 kg/m<sup>3</sup>

M E75 FPD-26

Mounting door sealing system for E75FP double-sash with four side E75270 with brush holder

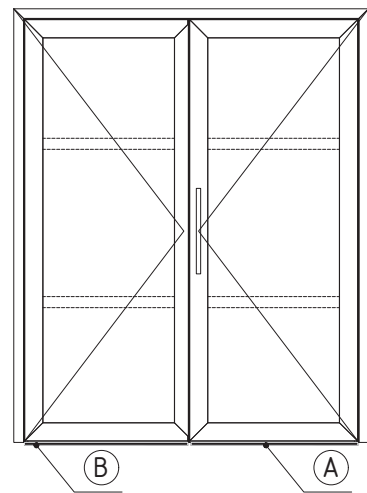

(A) Sealing system for active sash.  
Install cap A<sub>1</sub>

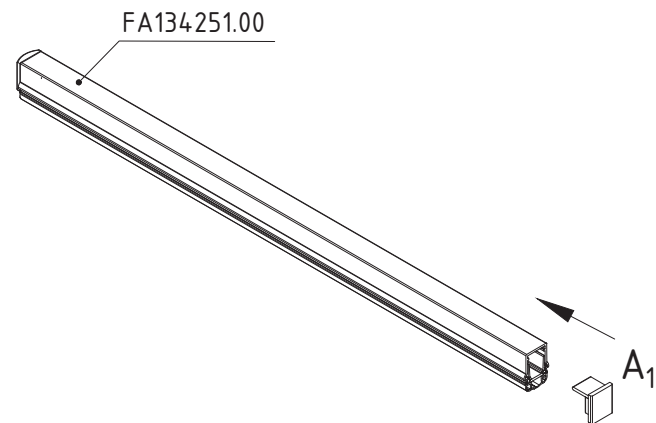

(B) Sealing system for passive sash.  
Install cap B<sub>1</sub>

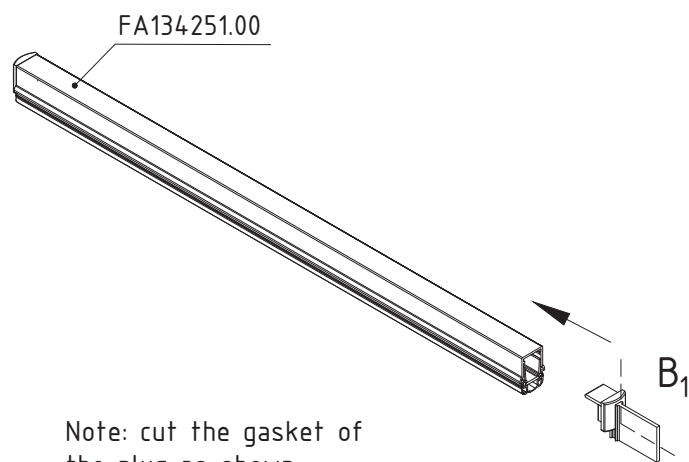

Note: cut the gasket of the plug as shown

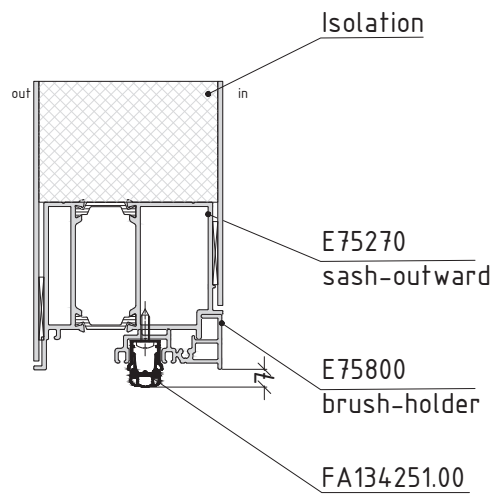
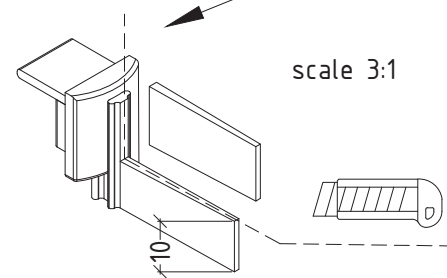

Caps in the package for door sealing system

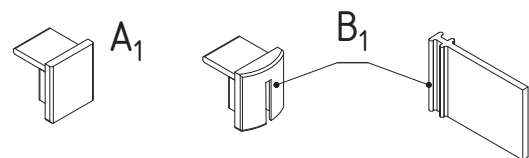

not to scale

M E75 FPD-27

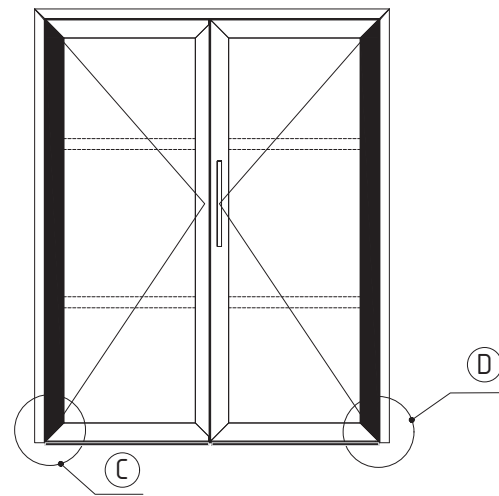

Note:  
Install the caps on both wings but only on the sash - frame side. In the middle the caps are different.

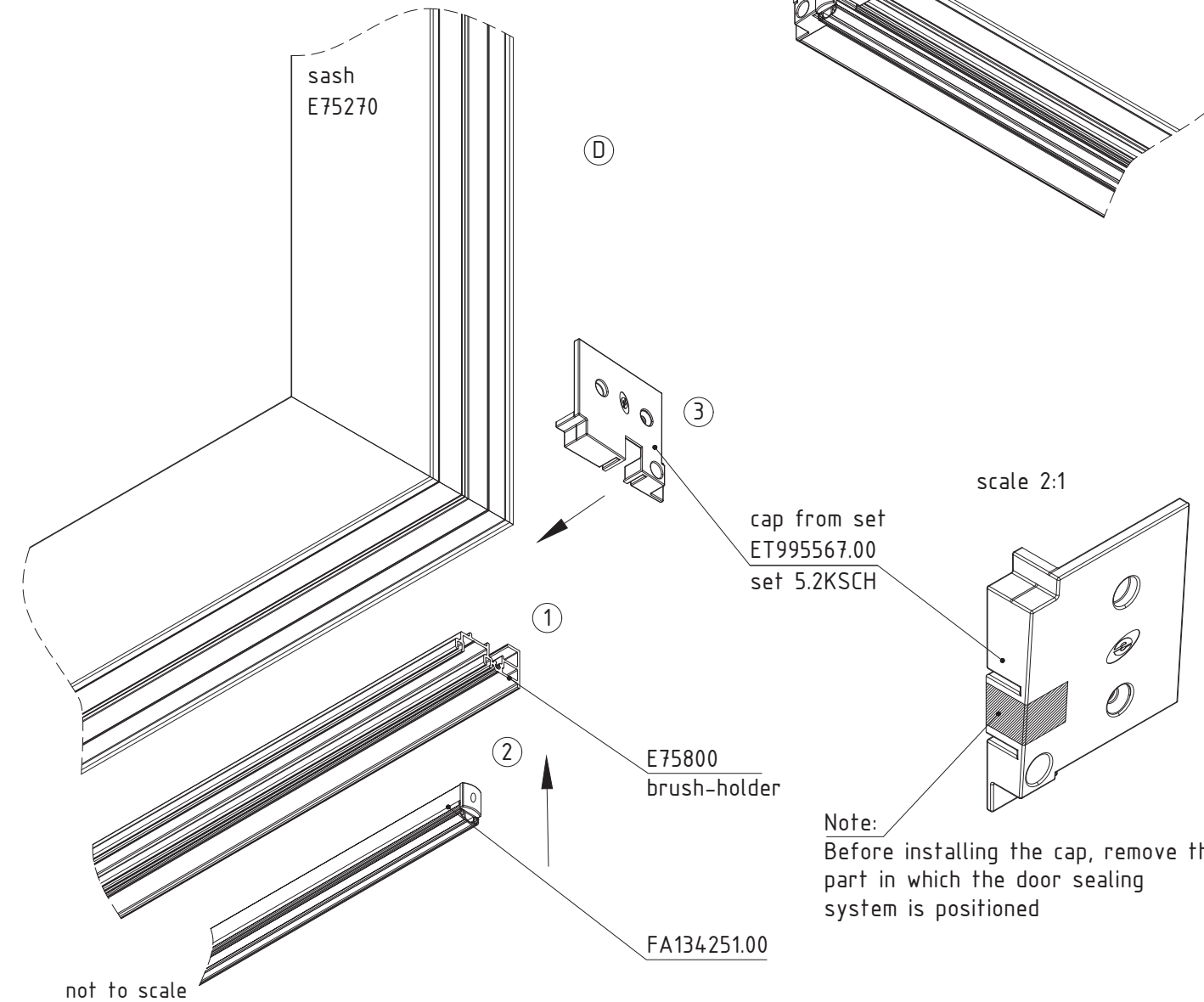
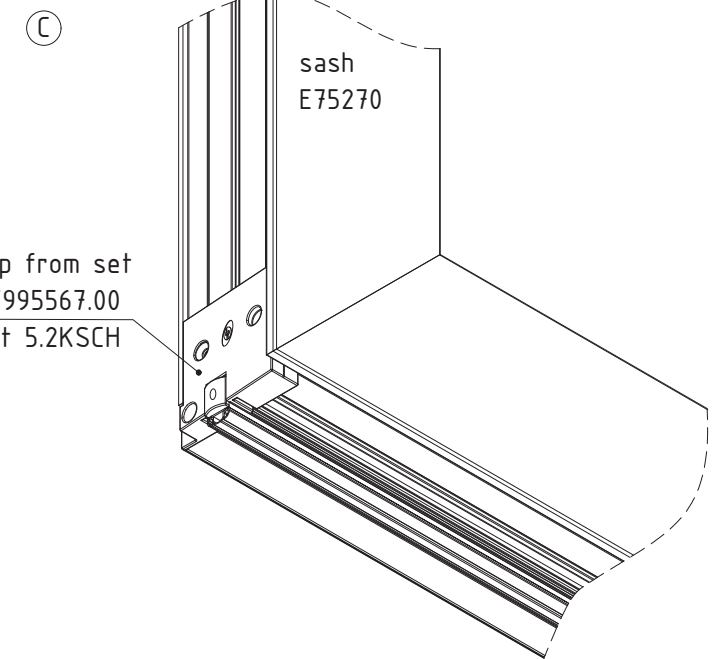

not to scale

M E75 FPD-28



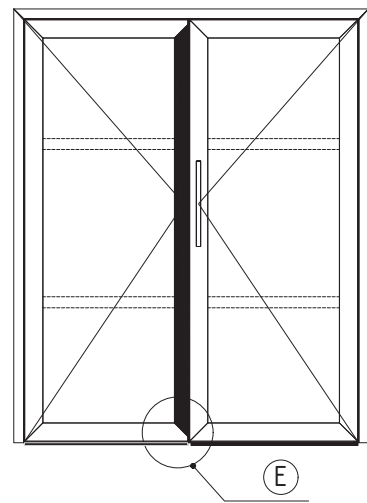

Note:  
Install the cap on the vertical profile of the passive sash from the handle side

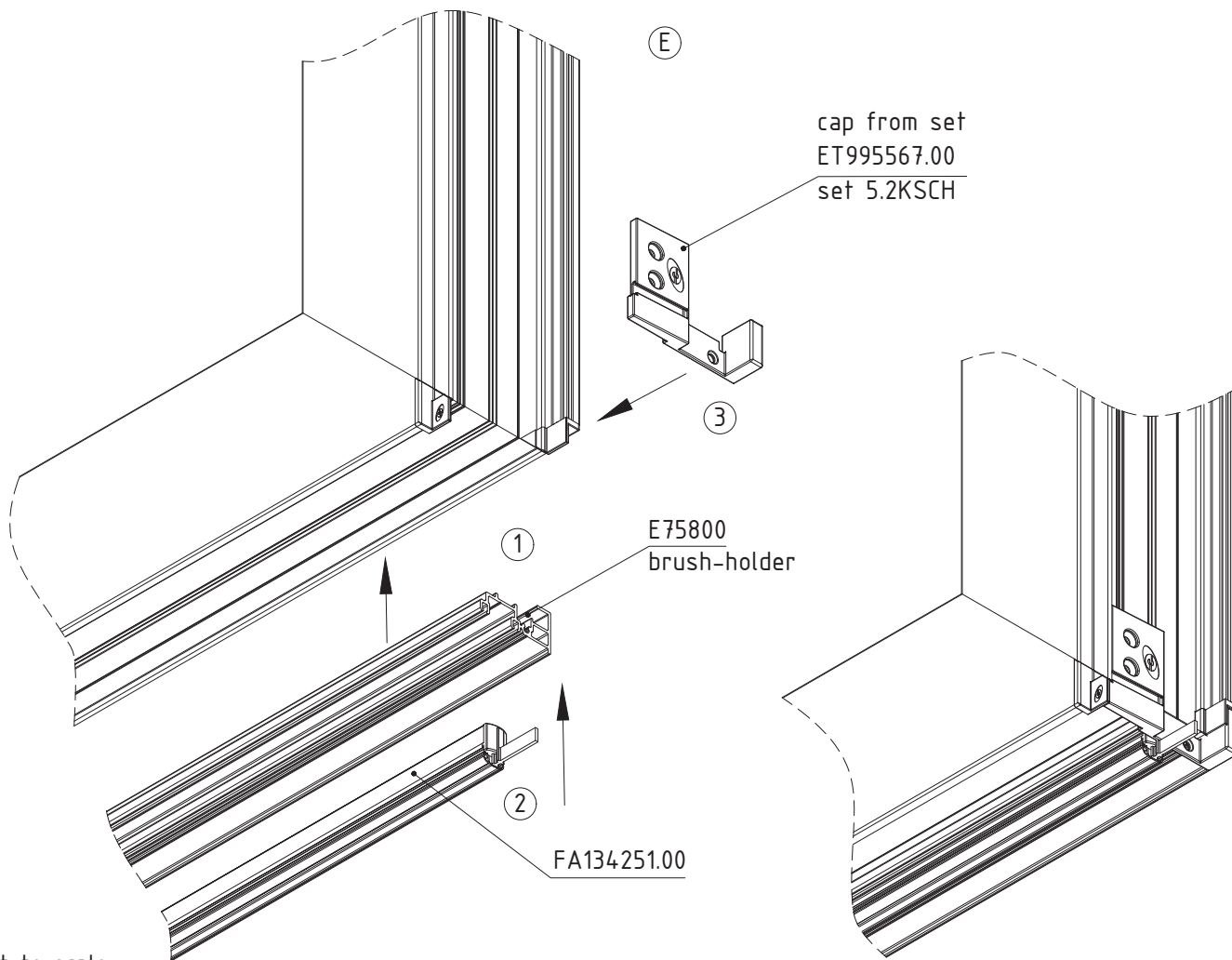
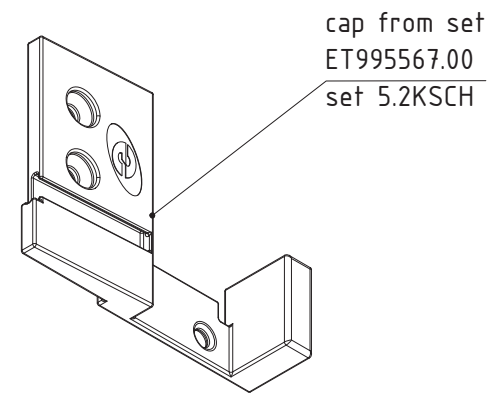

# ACCESSORIES

**flat panel door system with thermal break**

**E75FPD**

code/description	package/pcs	colour
ET <b>130502.00</b>	200	●

EPDM gasket



ET <b>130053.00</b>	-	●
---------------------	---	---

EPDM gasket

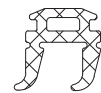

ET <b>130468.00</b>	100	●
---------------------	-----	---

outside silicone gasket

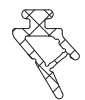

ET <b>130748.00</b>	100	●
---------------------	-----	---

EPDM gasket



## flat panel door system with thermal break

E75FPD

code/description	package/pcs	colour
ET <b>130491.00</b>	40	●

EPDM gasket

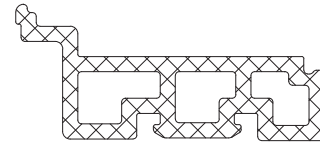

ET <b>130702.00</b>	12	●
---------------------	----	---

silicone gasket for E75 FPD



ET <b>054674.00</b>	200	MF
---------------------	-----	----

extruded aluminium corner bracket 6.4 mm for E75111

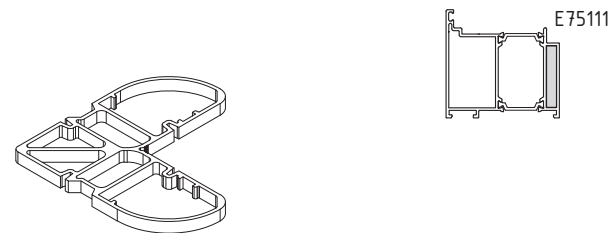

attention  
always use epoxy resin  
for long lasting joining

ET <b>054675.00</b>	50	MF
---------------------	----	----

extruded aluminium corner bracket 30.4 mm for E75111/E75210

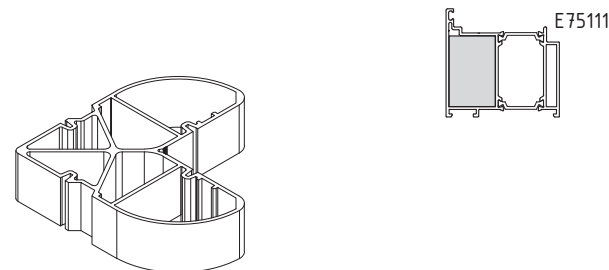

attention  
always use epoxy resin  
for long lasting joining

A E75 FPD-2

## flat panel door system with thermal break

E75FPD

code/description	package/pcs	colour
ET <b>054670.00</b>	150	MF

extruded aluminium corner bracket 6.4 mm for E75110

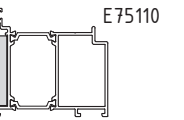
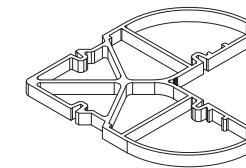

attention  
always use epoxy resin  
for long lasting joining

ET <b>054671.00</b>	100	MF
---------------------	-----	----

extruded aluminium corner bracket 21.9 mm for E75110/E75211/E75270

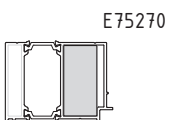
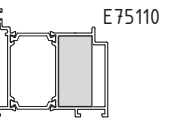
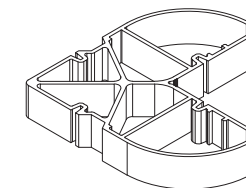

attention  
always use epoxy resin  
for long lasting joining

ET <b>054672.00</b>	100	MF
---------------------	-----	----

extruded aluminium corner bracket 8.2 mm for E75110/E75211

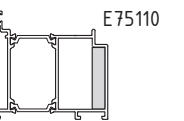
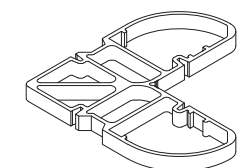

attention  
always use epoxy resin  
for long lasting joining

ET <b>054722.00</b>	75	MF
---------------------	----	----

extruded aluminium corner bracket 30.7 mm for E75112

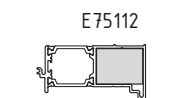
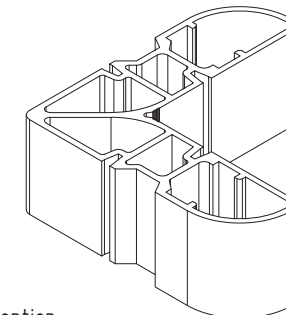

attention  
always use epoxy resin  
for long lasting joining

A E75 FPD-3

## flat panel door system with thermal break

E75FPD

code/description	package/pcs	colour
ET <b>054726.00</b>	-	MF

extruded aluminium corner bracket 26.4 mm for E75271

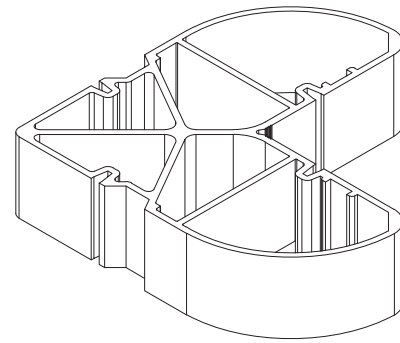

E75271

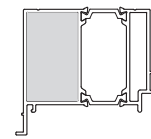

attention  
always use epoxy resin  
for long lasting joining

ET <b>054725.00</b>	-	MF
---------------------	---	----

extruded aluminium corner bracket 8.4 mm for E75270

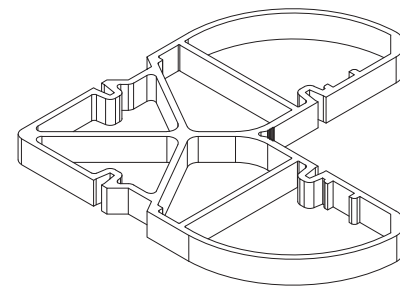

E75270

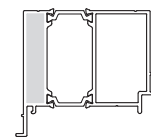

attention  
always use epoxy resin  
for long lasting joining

ET <b>054724.00</b>	-	MF
---------------------	---	----

extruded aluminium corner bracket 8.4 mm for E75270/E75271

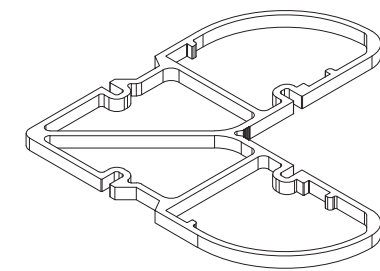

E75271

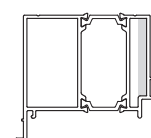

E75270

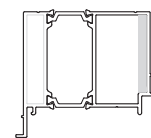

attention  
always use epoxy resin  
for long lasting joining

ET <b>054676.00</b>	200	MF
---------------------	-----	----

extruded aluminium corner bracket 3.9 mm for E75210

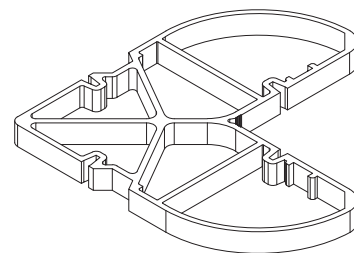

attention  
always use epoxy resin  
for long lasting joining

A E75 FPD-4

## flat panel door system with thermal break

E75FPD

code/description	package/pcs	colour
ET <b>055511.00</b>	100	MF

alignment square - inox for E75112

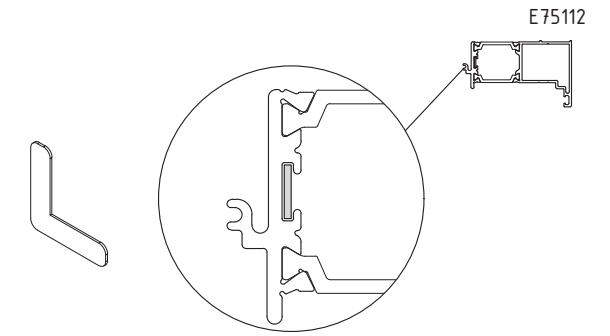

ET <b>055516.00</b>	1	-
---------------------	---	---

Steel anchor for E75

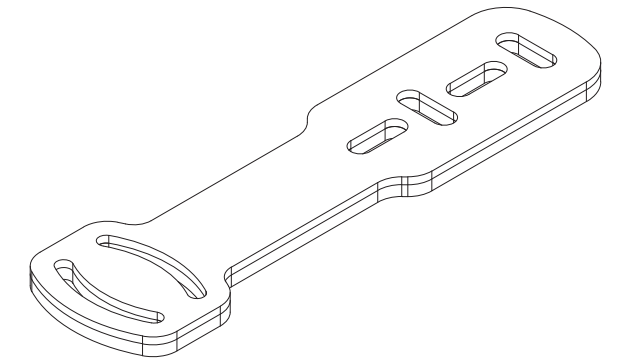

ET <b>080525.00</b>	2m	standard
---------------------	----	----------

additional insulator for E75110 E75111

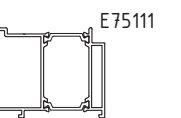
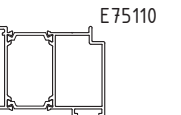
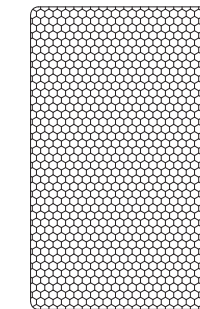

ET <b>080526.00</b>	2m	standard
---------------------	----	----------

additional insulator for E75210 E75211

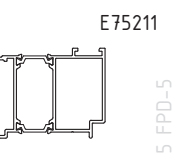
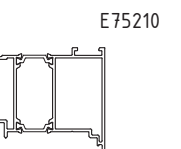
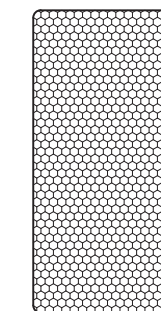

A E75 FPD-5

## flat panel door system with thermal break

E75FPD

code/description	package/pcs	colour
ET <b>975372.22</b>	1m	standard

additional insulator for  
E75372

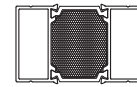
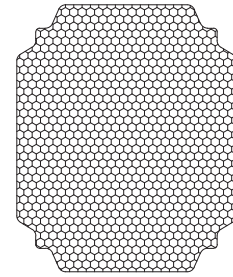

ET <b>130509.00</b>	40	●
---------------------	----	---

gasket for  
E75 FPD



ET <b>995564.00</b>	1	●
---------------------	---	---

SET 2.1KCCH

set pl. plugs for  
single-sash flat door  
with brush holder

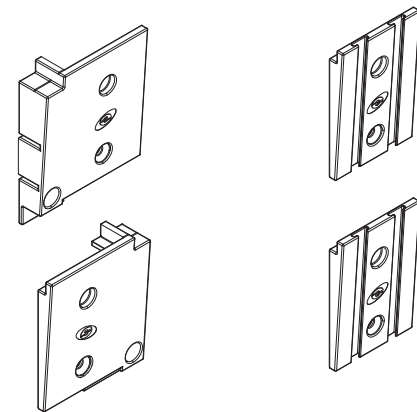

ET <b>995569.00</b>	1	●
---------------------	---	---

SET 1

set plugs for  
E75 FDP  
with thermal threshold

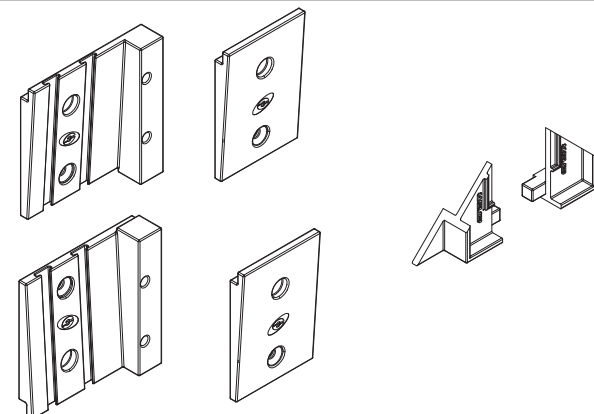

A E75 FPD-6

## flat panel door system with thermal break

E75FPD

code/description	package/pcs	colour
ET <b>995579.00</b>	1	●

SET 2

set plugs for double sash  
E75 FDP  
with brush holder

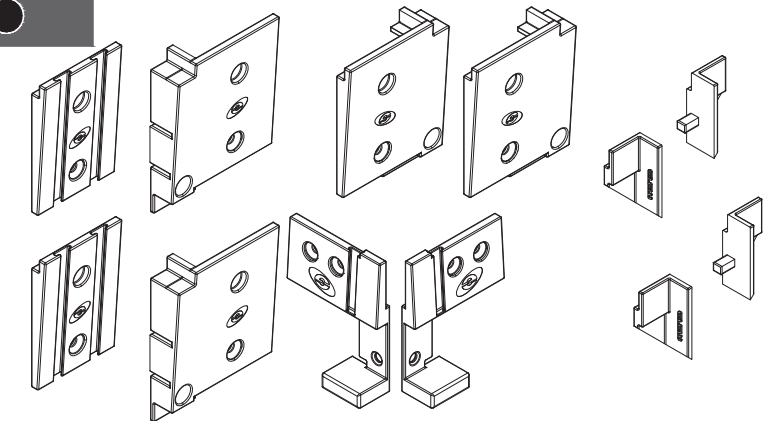

ET <b>995589.00</b>	1	●
---------------------	---	---

SET 3

set plugs for double sash E75  
FDP  
with thermal threshold

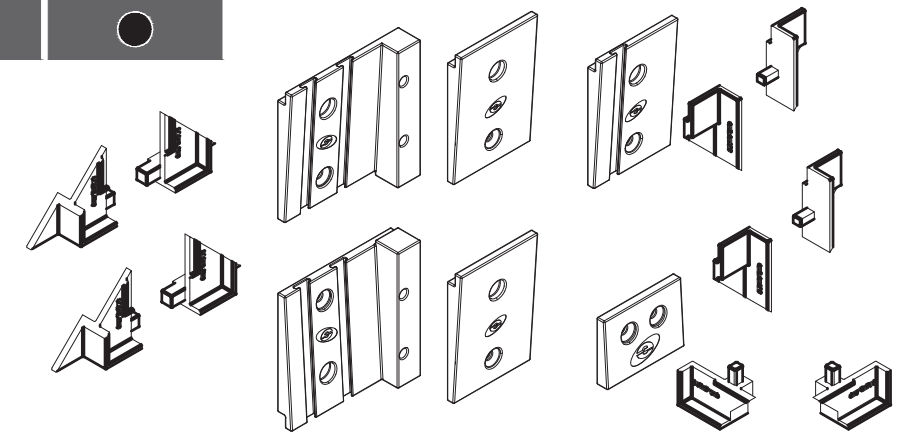

ET <b>070117.00</b>	-	MF
---------------------	---	----

aluminium corner for FPD +  
screws

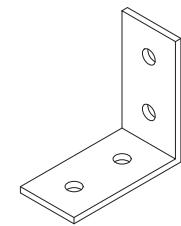

ET <b>994353.00</b>	-	-
---------------------	---	---

Primer



A E75 FPD-7

flat panel door system with thermal break

E75FPD

code/description	package/pcs	colour
ET <b>133504.00</b>	-	-

Type VHB 19mm

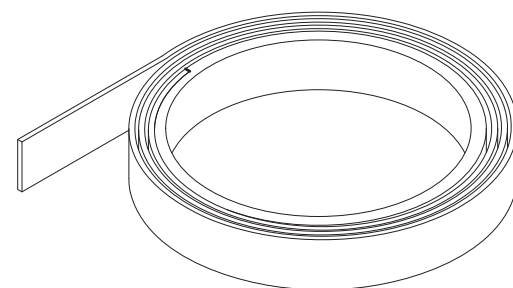

ET <b>074306.00</b>	100	●
---------------------	-----	---

plastic drainage cap 30x6mm

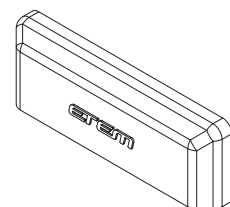

ET <b>074307.00</b>	100	●
---------------------	-----	---

flap for drainage cap

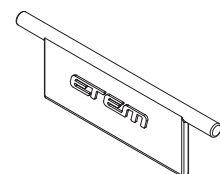

<b>GU 238893.00</b>	1	nickel
---------------------	---	--------

Security lock GU 35/92/240



A E75 FPD-8

flat panel door system with thermal break

E75FPD

code/description	package/pcs	colour
<b>GU235841.00</b>	-	-

Striker Up/Bottom

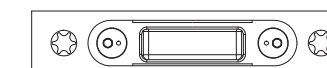

<b>GU235804.00</b>	-	-
--------------------	---	---

Middle strike plate  
Left

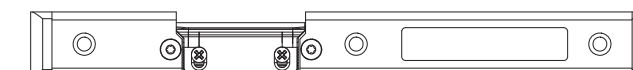

<b>GU235805.00</b>	-	-
--------------------	---	---

Middle strike plate  
Right

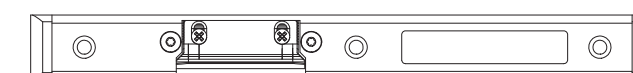

<b>GI027920.01</b>	10	●
<b>GI027920.06</b>	10	●
<b>GI027920.02</b>	10	●

Double handle for door Prima

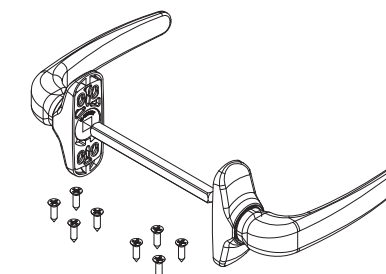

A E75 FPD-9

flat panel door system with thermal break

E75FPD

code/description	package/pcs	colour
<b>GI206672.01</b>	10	●
<b>GI206670.02</b>	10	●
<b>GI206671.06</b>	10	●

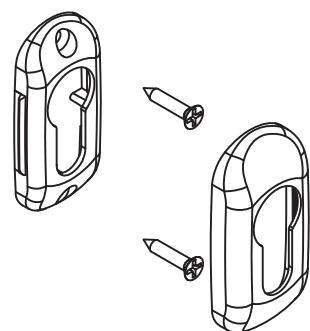

cover plate for cilinder

<b>GI039910.01</b>	-	●
<b>GI039910.02</b>	-	●
<b>GI039910.06</b>	-	●
<b>GI039910.12</b>	-	EV1 brushed

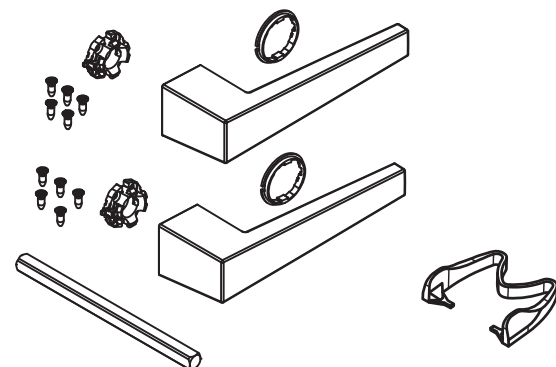

NP ultra door handle squared

<b>GI039920.01</b>	-	●
<b>GI039920.02</b>	-	●
<b>GI039920.06</b>	-	●
<b>GI039920.12</b>	-	EV1 brushed

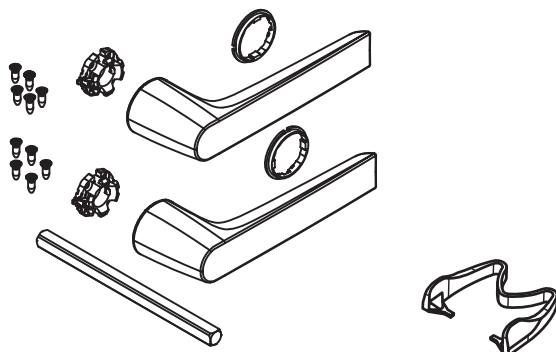

NP ultra door handle rounded

<b>GI050440.01</b>	-	●
<b>GI050440.02</b>	-	●
<b>GI050440.06</b>	-	●
<b>GI050440.12</b>	-	EV1 brushed

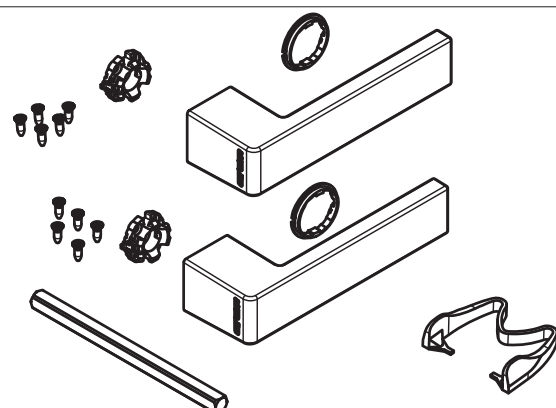

NP ultra door handle ETEM

A E75 FPD-10

flat panel door system with thermal break

E75FPD

code/description	package/pcs	colour
<b>GU24315.01</b>	-	●
<b>GU24315.02</b>	-	●
<b>GU24315.06</b>	-	●
<b>GU24315.12</b>	-	EV1 brushed

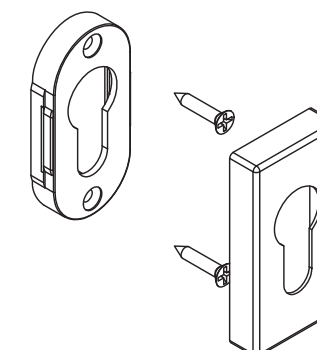

cylinder cover squared

<b>GU235824.00</b>	-	-
--------------------	---	---

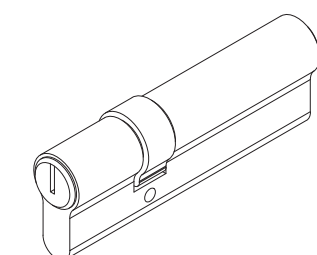

cilinder 35/65mm

ET <b>205114.01</b>	2	●
ET <b>205114.02</b>	2	●
ET <b>205114.11</b>	2	EV1

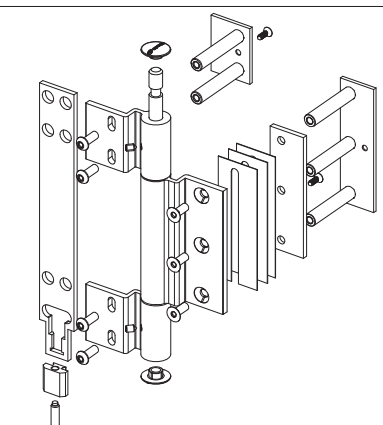

hinge ETEM Alpro

ET <b>205101.06</b>	2	●
ET <b>205101.02</b>	2	●

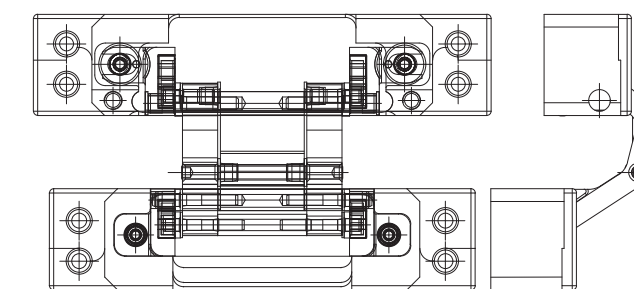

hidden hinge Simonswerk TECTUS

A E75 FPD-11

flat panel door system with thermal break

E75FPD

code/description	package/pcs	colour
ET <b>205102.00</b>	1	MF

fixing set for TECTUS

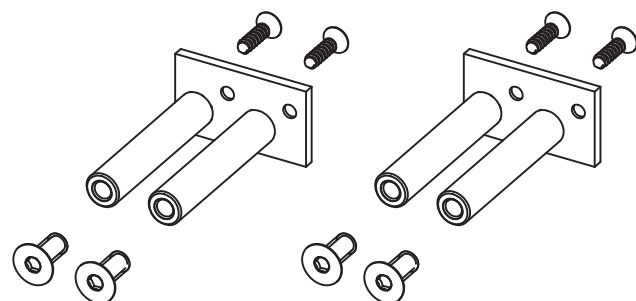

**GU235812.00**

-

-

box locking parts on hinge side U24x6

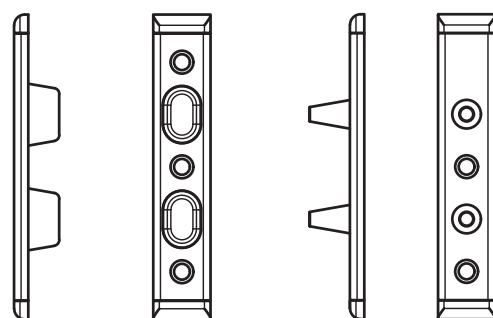

ET **994573.00**

10

●

bolt for secondary sash GIESSE

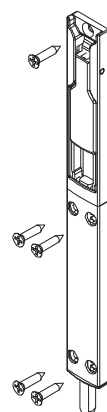

**GI206699.00**

100

nickel

striker for treshold giesse

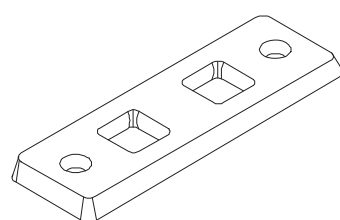

A E75 FPD-12

flat panel door system with thermal break

E75FPD

code/description	package/pcs	colour
<b>GI206682.00</b>	-	-

bottom striker for side hung bolt

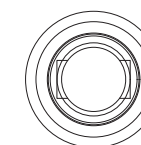
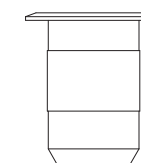

**GI206681.00**

-

-

upper striker for side hung bolt

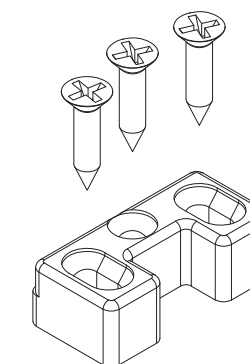

ET **074075.00**

-

-

striker plate

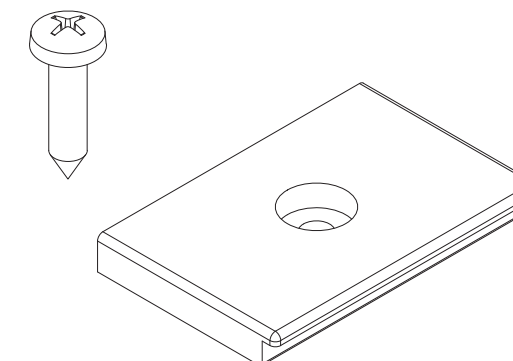



# CE MARKING

STANDARDS / PERFORMANCE CHARACTERISTICS

# CE MARKING

## WHAT DOES THE SIGN CE MEAN?

It is an abbreviation of the French "Conformite Europeene"- i.e. European Conformity. By placing the CE marking the manufacturer declares that the product complies with the general safety requirements set out in the Construction Product Regulation 305/2011.

## WHAT IS THE PURPOSE OF CE MARKING?

The CE marking represents "the European passport" of the product, its main objectives are:

CE is a declaration by the manufacturer that the product meets the essential requirements of relevant European legislation relating to health, safety and environmental protection;

CE indicates to officials in relevant ministries and departments that the product can be put on the market lawfully in the country;

CE ensures free movement of goods within the EU and the European Free Trade Association (EFTA);

CE permits the withdrawal of products that do not meet the standards by monitoring and custom authorities;

Marking with the CE mark is necessary in cases where the product is distributed within the internal market.

## WHAT ARE THE REQUIREMENTS FOR THE CE MARKING?

Doors, windows and gates (except those intended to be used for internal communication only, for fire/smoke compartmentation and on escape routes) are covered by System 3 of assessment and verification of constancy of performance.

According to the Construction Product Regulation 305/2011, this system sets the following duties:

Tasks to be performed by the manufacturer	Tasks to be performed by Notified testing laboratory	Conformity assessment (the basis for CE marking, which is set by the final producer)
factory production control - FPC	Determination of the product type on the basis of type testing, type calculation, tabulated values, etc.	Declaration of performance issued by the manufacturer or his authorized representative based on test results.

## LEGAL ACTS

- Construction Products Regulation (305/2011/EU - CPR) - replacing the Construction Products Directive (89/106/EEC - CPD)
- EN 14351-1:2006+A1:2010 - Windows and doors - Product standard, performance characteristics - Part 1: Windows and external pedestrian doorsets without resistance to fire and/or smoke leakage characteristics

# MAIN METHODS FOR OBTAINING TEST RESULTS BY THE MANUFACTURER

According to the Construction Product Regulation 305/2011 there are three main options for the manufacturers of windows and doors to obtain test results.

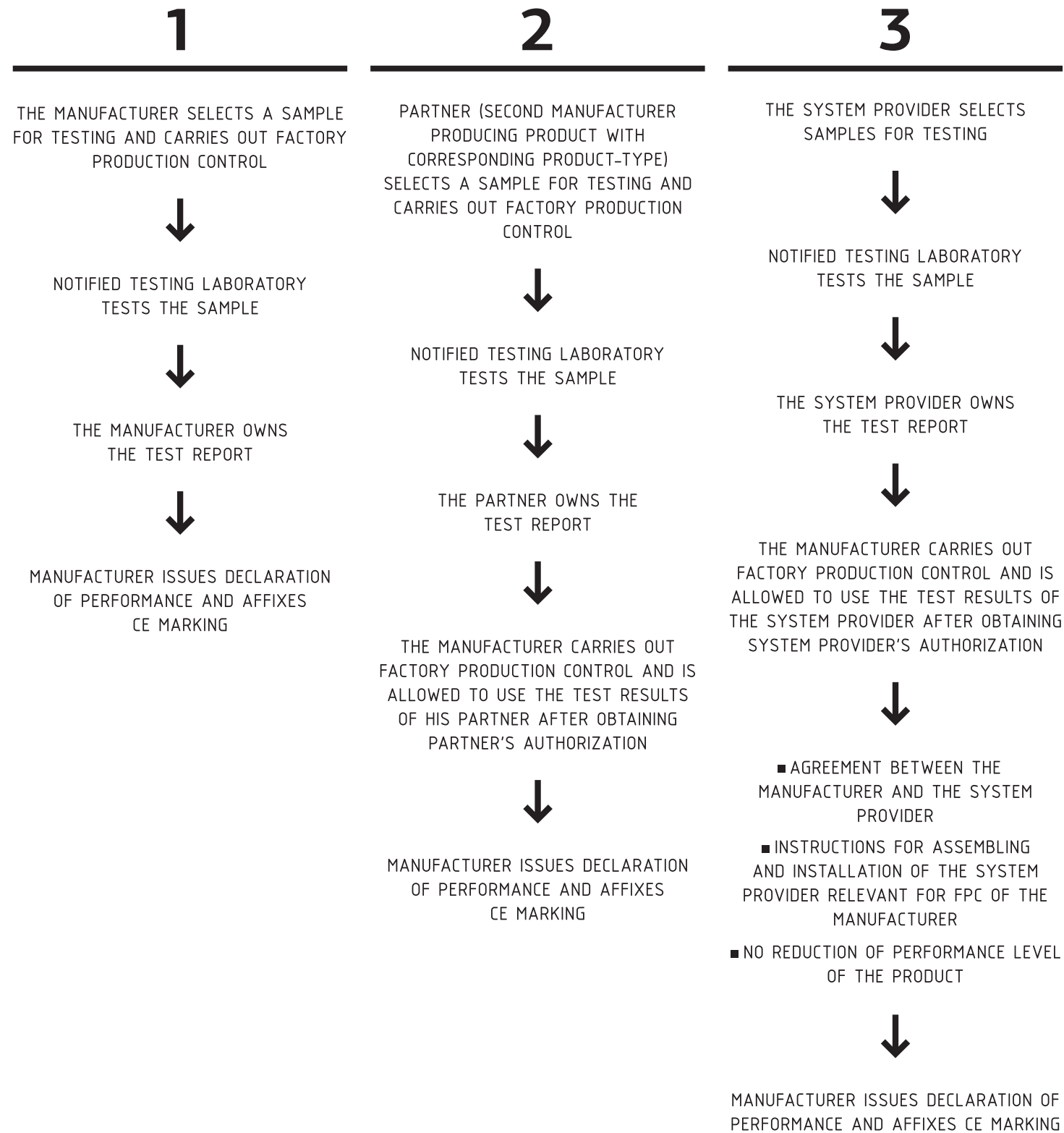

# STANDARDS

## GENERAL

- EN 12020 (1÷2) - ALUMINIUM AND ALUMINIUM ALLOYS - EXTRUDED PRECISION PROFILES IN ALLOYS EN AW-6060 AND EN AW-6063
- EN 755 (1÷9)- ALUMINIUM AND ALUMINIUM ALLOYS - EXTRUDED ROD/BAR, TUBE AND PROFILES
- EN 573 (1÷3) - ALUMINIUM AND ALUMINIUM ALLOYS - CHEMICAL COMPOSITION AND FORM OF WROUGHT PRODUCTS
- EN 1990 EUROCODE - BASIS OF STRUCTURAL DESIGN
- EN 1991 EUROCODE 1 - ACTIONS ON STRUCTURES
- EN 1998 EUROCODE 8 - DESIGN OF STRUCTURES FOR EARTHQUAKE RESISTANCE
- EN 1999 EUROCODE 9 - DESIGN OF ALUMINIUM STRUCTURES

## WINDOWS AND DOORS

1. EN 14351 - WINDOWS AND DOORS - PRODUCT STANDARD, PERFORMANCE CHARACTERISTICS
2. EN 12519 - WINDOWS AND PEDESTRIAN DOORS - TERMINOLOGY
3. EN 12207 - WINDOWS AND DOORS - AIR PERMEABILITY - CLASSIFICATION
4. EN 1026 - WINDOWS AND DOORS - AIR PERMEABILITY - TEST METHOD
5. EN 12208 - WINDOWS AND DOORS - WATERTIGHTNESS - CLASSIFICATION
6. EN 1027 - WINDOWS AND DOORS - WATERTIGHTNESS - TEST METHOD
7. EN 12210 - WINDOWS AND DOORS - RESISTANCE TO WIND LOAD - CLASSIFICATION
8. EN 12211 - WINDOWS AND DOORS - RESISTANCE TO WIND LOAD - TEST METHOD
9. EN 1191 - WINDOWS AND DOORS - RESISTANCE TO REPEATED OPENING AND CLOSING - TEST METHOD
10. EN ISO 10077 (1÷2) - THERMAL PERFORMANCE OF WINDOWS, DOORS AND SHUTTERS - CALCULATION OF THERMAL TRANSMITTANCE
11. EN 12412-2 - THERMAL PERFORMANCE OF WINDOWS, DOORS AND SHUTTERS - DETERMINATION OF THERMAL TRANSMITTANCE BY HOT BOX METHOD - PART 2: FRAMES
12. EN 13115 - WINDOWS - CLASSIFICATION OF MECHANICAL PROPERTIES - RACKING, TORSION AND OPERATING FORCES
13. EN 1627 - WINDOWS, DOORS, SHUTTERS - BURGLAR RESISTANCE - REQUIREMENTS AND CLASSIFICATION
14. EN 1628 - WINDOWS, DOORS, SHUTTERS - BURGLAR RESISTANCE - TEST METHOD FOR THE DETERMINATION OF RESISTANCE UNDER STATIC LOADING
15. EN 1629 - WINDOWS, DOORS, SHUTTERS - BURGLAR RESISTANCE - TEST METHOD FOR THE DETERMINATION OF RESISTANCE UNDER DYNAMIC LOADING
16. EN 1630 - WINDOWS, DOORS, SHUTTERS - BURGLAR RESISTANCE - TEST METHOD FOR THE DETERMINATION OF RESISTANCE TO MANUAL BURGLARY ATTEMPTS
17. EN ISO 717-1 - ACOUSTICS - RATING OF SOUND INSULATION IN BUILDINGS AND OF BUILDING ELEMENTS - PART 1: AIRBORNE SOUND INSULATION
18. EN ISO 10140 - ACOUSTICS - LABORATORY MEASUREMENT OF SOUND INSULATION OF BUILDING ELEMENTS

# HATCHES

Hatches for different materials

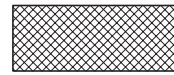

EPDM

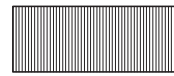

PVC

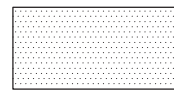

gypsum board



silicone seal

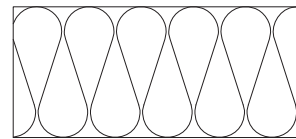

Insulation soft

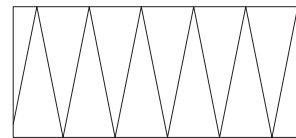

Insulation hard

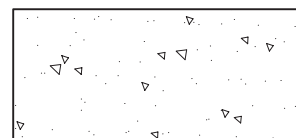

concrete wall

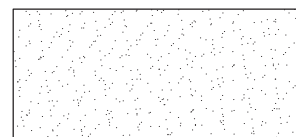

plaster

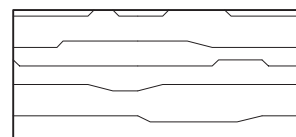

wood



butyl seal



membrane

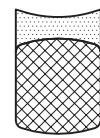

silicone seal



backer rod



PVC spacer



etalbond

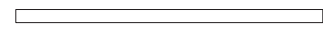

sheet aluminium

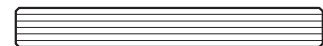

glass



aluminium profile

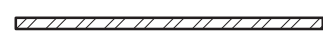

steel

# LIABILITY

The stated data and calculating methods are provided by ETEM as a guideline only. The information given in this catalogue does not substitute all applicable regulations – Eurocodes, harmonized European standards, national or regional building codes.

The specific conditions and technical details of every particular project have to be taken into consideration.

The right choice of all elements as well as any special requirements regarding stability of the structure must always be considered by the structural/façade engineer, responsible for the project.

The solutions presented in these pages are indicative and can not cover all possible project cases. Because of that every single project has to be evaluated by the structural/facade engineer in charge taking into consideration the specific features, such as climate conditions, location, orientation, etc.

ETEM is not liable for any calculations and conclusions made on the basis of the stated information. All calculations and specifications must be estimated, endorsed and guaranteed by architect, engineer, professional or legal entity authorized by law for such activities.

# COPYRIGHT

Copyright© 1 edition, 2021 ETEM

The design, structure and content of this catalogue are subject of copyright and the exclusive rights belong to ETEM. Modifying, copying, publishing, selling or licensing any part or the whole content of this catalogue is strongly prohibited without the permission of ETEM.

Any unauthorized use of content may violate copyright or other laws.

## DISCLAIMER

ETEM is not responsible for any typographical errors, technical inaccuracies and following changes of the content of this catalogue.

Before starting manufacturing process, it is highly recommended to contact ETEM R&D department in order to provide you with updated information.

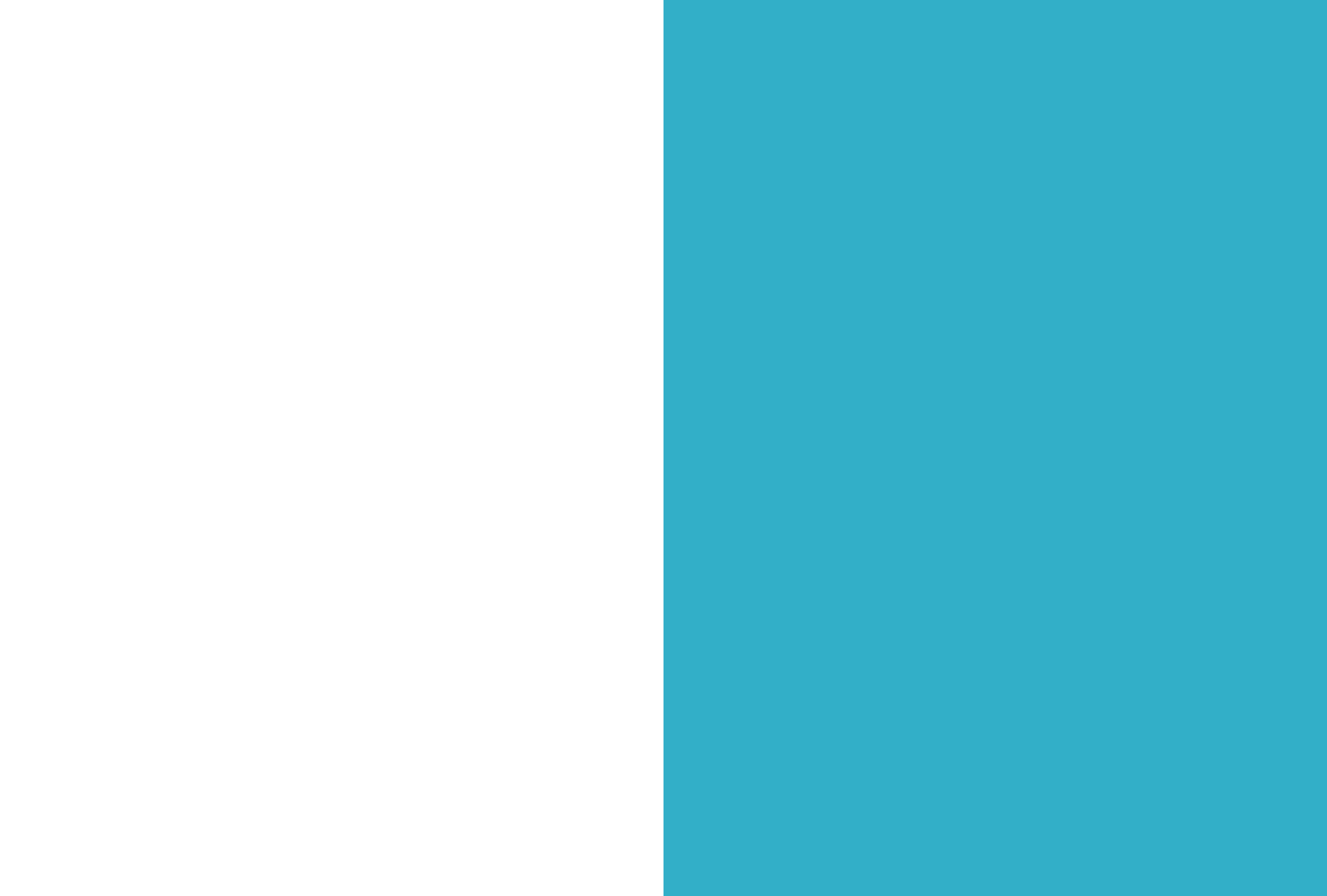



[WWW.ETEM.COM](http://WWW.ETEM.COM)

**ETEM**