

E75 VARIO

TECHNICAL CATALOGUE

VENTILATED FAÇADE SYSTEMS
FOR CLADDING MATERIALS

E52

Q60

E97 E40

E19 E8000

BRAVO

E85 E70

FORTE

E97 VFS – II EDITION

VENTILATED FAÇADE SYSTEMS

TABLE OF CONTENTS

ETEM HISTORY	page 6
GENERAL INFORMATION	page 9
BUILDING PHYSICS	page 19
FIXING BRACKETS AND ACCESSORIES	page 35
SYSTEMS	page 43
BRAVO	page 45
BRAVO W	page 47
BRAVO U	page 53
BRAVO Y	page 59
BRAVO H	page 65
VARIO	page 71
VARIO Lamella	page 73
VARIO GH	page 79
VARIO Glue	page 85
VARIO Fixings	page 91
VARIO Clips	page 100
FORTE	page 106
FORTE Light	page 108
FORTE	page 114
FORTE Pins	page 120
CLADDING MATERIALS	page 126
STANDARDS	page 132

ETEM HISTORY

ETEM is a leading aluminium extrusion company. It was founded in 1971 as a part of the largest metal manufacturing holding on the Balkans. With over 40 years of experience, ETEM is a fully integrated designer and producer of architectural systems and aluminium profiles for industrial applications.

Our mission is to listen and promptly respond to our customers' requests and design and manufacture aluminium products and systems, taking into consideration technical and aesthetic requirements.

ETEM focuses on sustainable development and has proven its concern about the protection of the natural environment, by making considerable investments in anti-pollution measures and by optimizing production processes, following the applicable standards of the European Union.

SERVICES WE PROVIDE

ETEM supports you with the following:

- ▷ design of conventional and bespoke architectural system solutions
- ▷ innovative engineering in the field of curtain walls, ventilated facades, doors, windows
- ▷ professional consultation and adequate technical advices, ensured by our engineering team with wide experience in the field of profile extrusion as well as architectural systems' engineering

- ▷ reliable customer care, constant support trainings, technical support and audits on site
- ▷ high quality engineering, which guarantees offering the best solution according to the specific features of every single project
- ▷ managing the process of certification in accordance with the applicable European standards in Notified Bodies
- ▷ production of non-standard length profiles and non-standard processing
- ▷ high quality powder coating

ETEM PRODUCTS AND SUSTAINABLE DEVELOPMENT

SUSTAINABLE DEVELOPMENT IS DEVELOPMENT, THAT MEETS THE NEEDS OF THE PRESENT, WITHOUT COMPROMISING THE ABILITY OF FUTURE GENERATIONS TO MEET THEIR OWN NEEDS.*

For many, sustainable development is about environmental conservation. This is true but it also includes two other aspects: a social aspect and an economic aspect.

Sustainable development means striking the right balance between economic development, social equity and environmental protection.

For us meeting this objective translates into the challenge of satisfying market demands at the lowest economic, social and environmental cost possible.

ETEM has always designed architectural systems, which are in compliance with all requirements for achieving high energy efficiency.

In order to assure the comfort of the building inhabitants, ETEM systems adapt their functions to the changing environment.

As a moderator between outside and inside our systems provide:

- > ENERGY EFFICIENCY
- > DAYLIGHT
- > SUN-SHADING
- > VENTILATION AND GOOD AIR QUALITY
- > SAFETY AND SECURITY

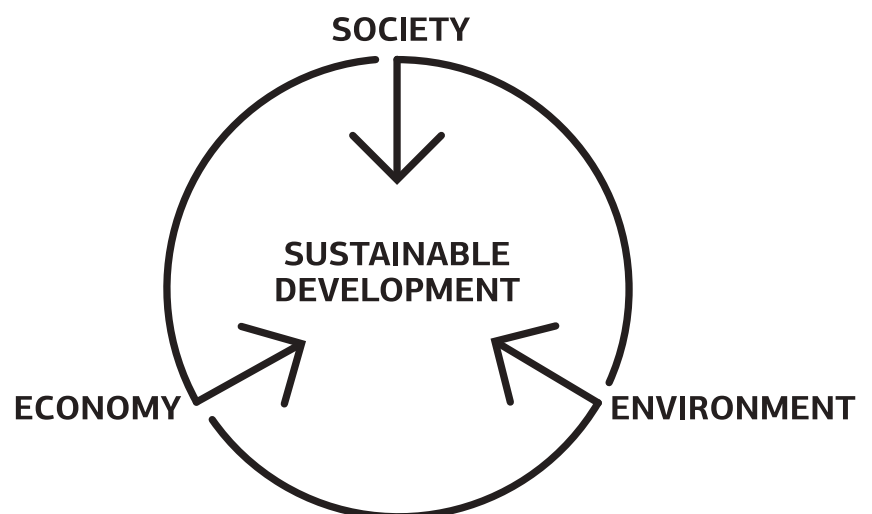

GENERAL INFORMATION

CONCEPT / ADVANTAGES / CERTIFICATES

E97 CONCEPT

VENTILATED FAÇADE SYSTEM (VFS) IS AN ELEMENT OF THE BUILDING ENVELOPE, WHICH INCLUDES ALL WINDOWS, DOORS AND FLASHINGS, PARAPETS, LOUVERS, ETC.

VFS IS CONSTRUCTED FROM FULLY FINISHED COMPONENTS AND ASSEMBLIES.

VFS IS A WALL, COMPRISING OUTER SKIN PANELS AND AN AIRTIGHT INSULATED BACKING WALL, SEPARATED BY A VENTILATED CAVITY.

The Ventilated façade ensures protection of the backing walls by integrating the following fundamental aspects:

- **Weatherproofing**

The VFS shields the backing wall from direct rain

- **Wall's ventilation**

The characteristic that has always distinguished the VFS from other façade systems is that it creates an **air cavity**, which ensures the wall's ventilation and protection.

- **Drainage**

Further penetration of water passing the rainscreen is prevented by the air gap and water is removed from the air gap by drainage and ventilation.

- **Features of the VFS**

Outer skin of panels, the rainscreen;

Air cavity, at least 30 mm deep;

Insulated backing wall that controls air leakage.

Clamps for fast and secure fixing
and clearance compensation

Variety of wall brackets

Fixing bracket with special design
reducing the stress in the angle

Hanger made from extruded aluminum
profile with special click design

Oval hole allowing precise positioning
of the wall brackets on the backing wall

Circular and oval shaped holes allowing
fixed and flexible supports

Fastener for final hanger fixation

Specially designed T-slot for fast
and easy mounting

Oval and circular holes allowing
elongation and for final adjustment
of the cassettes

ENF-aluminium metal sheet
Non-combustible material

Specially designed aluminum extruded
main supporting profile

Increased stability of the
cassettes ensured by bendings

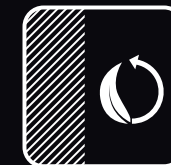
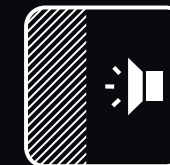
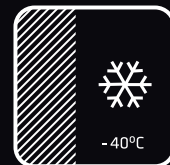
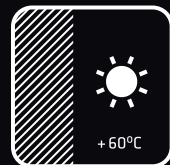

ADVANTAGES OF VENTILATED FAÇADE SYSTEMS

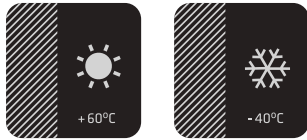

Energy saving and Energy efficiency

The topic of Energy Efficiency is one of the most widely discussed during the last few years. The climate changes are already a fact. The severe exploitation of natural resources is the main reason for that. The depletion of conventional energy resources forces reconsideration of the national energy strategies and make them part of one common World Strategy. The main advantage of ETEM ventilated systems is energy saving. The correct design and implementation of the systems reduce energy losses and energy expenses, increases the comfort of the premises, ensure healthy surroundings and help the environmental protection.



Excellent outer appearance

Besides the excellent vision, which is due to the diversity of materials and the combinations between them, the façade materials protect the building's external surface from the environment and keeps its integrity. A new aspect of the ventilated systems – the cladding of photovoltaic panels is possible. This is a non-conventional, "green" energy source.



Natural ventilation and Vapor permeability

Besides the thermal insulation, the natural ventilation and the vapour permeability are also very important for the inner microclimate.

The recommended width of the air gap, necessary for the existence of convection, is between 40 and 80 mm. This air gap protects the building from overheating during the summer and cooling down during the winter.

The ventilated façades allow the building to breathe and eliminate the condensation inside the premises. The vapor permeability of the enclosing walls and the thermal insulation let the construction moisture evaporate (this is valid for new buildings), and in premises with higher humidity – to be released outside. The absence of culture for airing the inhabited premises is also a reason for the existence of moisture and microorganisms. Devices with or without sensors are being developed in order to maintain ventilation in frames and suspended façades. This process is natural for the ventilated façades.



Sound insulation

The presence of air gap between the cladding material and the thermal insulation provides high level of noise insulation, a parameter which is very important for life in a big, urbanized city.



Fire Resistance

This is one of the most important advantages of ETEM ventilated systems. Some of the cladding materials are fire resistant. The others have non-burning cores or are mounted on certain height, according to the European regulations for fire safety. The combination between fire resistant façade materials and specially designed system, additionally increases the fire resistance of the building.



Fast mounting and Easy maintenance

An important parameter of ETEM systems is the speed of mounting and maintenance. Specially designed to decrease the time for designing and mounting, ETEM ventilated systems are the only solution for large façades, short deadlines, safety and excellent vision. A big advantage in the polluted urban environment is the self - cleaning feature of some of the cladding materials and the easy cleaning of the others.



Sustainability

Made of aluminium, material which is fully recyclable, ETEM VFS systems make a contribution to the creation of building envelope, which is sustainable throughout the whole building lifecycle – from cradle to cradle.

COMPLIANCE WITH APPLICABLE REGULATIONS

Production management

Quality management system is certified in accordance with EN ISO 9001:2008.

Environmental management system is certified in accordance with EN ISO 14001.

Factory production control system is certified according to the requirements of EN 15088.

ETEM is authorized to use the QUALICOAT quality sign for paint, lacquer and powder coating on aluminium for architectural applications.

Occupational health & safety Management system is certified in accordance with OHSAS 18001.

Performance characteristics of ETEM VFS systems

Ventilated façade systems ETEM were certified by notified laboratories all over the world according to the requirements of different standards:

- loadbearing capacity of the structure;
- loadbearing capacity of every single fixing bracket when loaded from different directions;
- resistance to wind load;
- impact resistance;
- weather tightness according to CWCT standard.

Tests were performed and reports were issued by the following notified bodies: Wintech Engineering, UK; Istituto Giordano, Italy; Building Research Institute, Bulgaria.

TEST REPORTS ETEM VENTILATED FAÇADE SYSTEMS

TEST SAMPLE	PERFORMANCE CHARACTERISTIC	STANDARDS
VARIO Clips	Resistance to wind load	EN 1991-1-4
	Impact resistance	EN 14019
VARIO Undercut (FORTE Light)	Water penetration (dynamic aero engine)	CWCT
	Wind Resistance (serviceability)	
	Wind Resistance (safety)	BS 8200
	Impact (safety – hard & soft body)	
VARIO G&H (VARIO GH)	Resistance to wind load	EN 13830 / 12179
	Frontal deflection at positive/ negative pressure 1000Pa	
	Residual deformation at positive/ negative pressure 1000Pa	
VARIO Rivets (VARIO Fixings)	Resistance to wind load	EN 13830 / EN 12179
	Frontal deflection at positive/ negative pressure 1000Pa	
	Residual deformation at positive/ negative pressure 1000Pa	
VARIO Glue	Resistance to wind load	EN 13830 / EN 12179
	Frontal deflection at positive/ negative pressure 1000Pa	
	Residual deformation at positive/ negative pressure 1000Pa	
VARIO Lamella	Resistance to wind load	EN 13830 / EN 12179
	Frontal deflection at positive/ negative pressure 1000Pa	
	Residual deformation at positive/ negative pressure 1000Pa	
	Impact (safety – hard & soft body)	
BRAVO etalbond® (BRAVO W)	Resistance to wind load	EN 1991-1-4
	Impact resistance	EN 14019
FORTE Undercut (FORTE)	Water penetration (dynamic aero engine)	CWCT
	Wind Resistance (serviceability)	
	Wind Resistance (safety)	BS 8200
	Impact (safety – hard & soft body)	
FORTE Light (Corian®)	Resistance to wind load	EN 13830 / EN 12179
	Frontal deflection at positive/ negative pressure 1000Pa	
	Residual deformation at positive/ negative pressure 1000Pa	
	Impact (safety – hard & soft body)	

CLADDING MATERIALS TABLE

ETEM System/ Cladding materials	Ceramic Tiles	Cement Board	Glass	Aluminium Composite Material (etalbond®)	Metal Sheet Products	High Pressure Laminates (HPL)	Fibre cement	Stone	Technical Stone	Composite Mineral Material	Glass Fiber Reinforced Concrete GFRP, GFRP	Light transmitting Concrete	ETEM Aluminium Lamellas
BRAVO W	X	X	X	V	V	X	X	X	X	X	X	X	X
BRAVO U	X	X	X	V	V	X	X	X	X	X	X	X	X
BRAVO Y	X	X	X	V	V	X	X	X	X	X	X	X	X
BRAVO H	X	X	X	V	V	X	X	X	X	X	X	X	X
VARIO Lamella	X	X	X	X	X	X	X	X	X	X	X	X	V
VARIO GH	V	X	V	X	X	V	V	V	V	X	V	V	X
VARIO Glue	X	X	V	X	X	V	V	X	X	V	V	X	X
VARIO Fixings	X	V	X	X	X	V	V	X	X	V	V	V	X
VARIO Clips	V	X	V	X	X	V	V	V	V	V	V	V	X
FORTE Light	V	X	V	X	X	V	V	V	V	V	V	V	X
FORTE	V	X	X	X	X	X	X	V	V	X	X	V	X
FORTE Pins	X	X	X	X	X	X	X	V	V	X	X	V	X

BUILDING PHYSICS

DIMENSIONING / FORMULAS / EXAMPLES

ALUMINIUM AS MATERIAL

ALUMINIUM IS A RATHER NEWFOUND METAL, EXTRACTED FOR THE FIRST TIME IN 1854. COMMERCIALY PRODUCED AS A PRECIOUS METAL FROM 1886, ITS' INDUSTRIAL PRODUCTION FOR CIVIL APPLICATIONS ONLY ACHIEVED WIDE USE IN THE 1950'S.

NOW ALUMINIUM PLAYS A KEY ROLE FOR THE SUSTAINABILITY OF NEW BUILDINGS AND THE RENOVATION OF EXISTING ONES. THANKS TO ITS' PERFORMANCE PROPERTIES ALUMINIUM CONTRIBUTES TO THE ENERGY PERFORMANCE, SAFETY AND COMFORT OF NEW BIULDINGS.

ADVANTAGES

DESIGN FLEXIBILITY

The extrusion process offers an almost infinite range of forms and sections, allowing designers to integrate numerous functions into one profile

LONG SERVICE LIFE

Aluminium building products are made from alloys that are weatherproof, corrosion-resistant and immune to the harmful effects of UV rays, ensuring optimal performance over a very long period of time

HIGH STRENGTH-TO-WEIGHT RATIO

Thanks to the metal's inherent strength and stiffness, aluminium window and curtain wall frames can be very narrow. Material's light weight makes it easier to transport and handle on-site, reducing the risk of work-related injury

HIGH-REFLECTIVITY

This characteristic feature makes aluminium a very efficient material for light management. Aluminium shading devices can be used to reduce the need for air conditioning in summer

FIRE SAFETY

Aluminium does not burn and therefore is classified as a non-combustible construction material (European Fire Class A1). Aluminium alloys will nevertheless melt at around 6500 C, but without releasing harmful gases

NO RELEASE OF DANGEROUS SUBSTANCES

Several studies have proved that aluminium building products do not present a hazard to occupants or the surrounding environment. Aluminium building products have no negative impact, either on indoor air quality or on soil, surface and groundwater

OPTIMAL SECURITY

Where high security is required, specially designed, strengthened aluminium frames can be used. While the glass for such applications may well be heavy, the overall weight of the structure remains manageable, thanks to the light weight of the aluminium frames.

ALLOYS

Aluminium in its' pure form is a very soft metal. Thanks to the addition of alloying elements such as copper, manganese, magnesium, zinc, etc. and thanks to suitable production processes, the physical and mechanical properties can be varied in a wide range to satisfy the requirements of a large number of different applications.

ETEM profiles are extruded from the following alloys:

EN AW-1050 [Al 99.5]

EN AW-6060 [Al Mg Si]

EN AW-6063 [Al Mg0,7 Si]

EN AW-6061 [Al Mg1 Si Cu]

EN AW-6005 [Al Si Mg]

EN AW-6082 [Al Si1 Mg Mn]

The most common aluminium alloys used by ETEM are EN AW-6063 and EN AW-6060.

Here are the properties of these alloys according to EN 755-2 and Eurocode 9

MATERIAL PROPERTIES

Aluminium alloy	EN AW-6063 T6	EN AW-6060 T66
Ultimate tensile strength	$R_m = 215 \text{ MPa}$ (wall thickness $\leq 10 \text{ mm}$) $R_m = 195 \text{ MPa}$ (10 mm < wall thickness $\leq 25 \text{ mm}$)	$R_m = 215 \text{ MPa}$ (wall thickness $\leq 3 \text{ mm}$) $R_m = 195 \text{ MPa}$ (3 mm < wall thickness $\leq 25 \text{ mm}$)
Tensile yield strength	$R_{p0,2} = 170 \text{ MPa}$ (wall thickness $\leq 10 \text{ mm}$) $R_{p0,2} = 160 \text{ MPa}$ (10 mm < wall thickness $\leq 25 \text{ mm}$)	$R_{p0,2} = 160 \text{ MPa}$ (wall thickness $\leq 3 \text{ mm}$) $R_{p0,2} = 150 \text{ MPa}$ (3 mm < wall thickness $\leq 25 \text{ mm}$)
Modulus of elasticity	$E_{al} = 70\,000 \text{ N/mm}^2 = 7 \cdot 10^9 \text{ kg/m}^2$	
Coefficient of thermal expansion	$\alpha = 0.023 \text{ mm/m} \cdot \text{K}$ (up to 1.2 mm/m for difference up to 50°C)	

EXTRUSION PROCESS

ETEM profiles are obtained through extrusion process, which consists of pushing a hot cylindrical bullet of aluminium through a shaped die. The extrusion process offers almost infinite range of forms and sections, allowing our designers to integrate numerous functions into one single profile.

aluminium surface, increasing hardness, corrosion and abrasion resistance. Anodizing gives a very typical silver matt surface finish, and colors can also be obtained by sealing metallic dyes into the anodized layer.

FINISHING

POWDER COATING

It is a type of paint that is applied as a dry powder. Coating is applied on ETEM profiles electrostatically and then is cured under heat to allow it to flow and form a "skin".

ETEM is authorized to use the quality sign QUALICOAT for powder coatings on aluminium for architectural applications. A wide range of colors and gloss levels can be achieved.

ETEM also offers timber imitations painting, in addition to all RAL colors. The technology EZY provides the following colors: Golden Oak, Acero, Betulla, Mogano, Verde Scuro, Wenge, Noce Fiammato, Noce Chiaro, Ciliegio Rosso, Acacia Scuro, Ciliegio Antico, Noce Reale, Ciliegio Reale.

ANODIZING

It is an electrochemical process which thickens the natural oxide film on the

MAINTENANCE

Apart from routine cleaning for aesthetic reasons, ETEM aluminium profiles do not require any maintenance, which translates into a major cost and ecological advantage over the lifetime of the product

RECYCLING

Aluminium scrap can be repeatedly recycled without any loss of value or properties. In many instances, aluminium is combined with other materials such as steel or plastics, which are most frequently mechanically separated from aluminium before being molten.

WIND LOAD

Wind actions

The main influence over the façade is wind action, which depends mainly on the height of the curtain wall and location.

As a guideline, the wind pressure values with respect to the structure height are given in the table below:

h	v	q		wind pressure	suction in middle zone		suction in edge zone
				$c_p = 0,8$	$c_p = 0,5$ $h/b \leq 0,25$	$c_p = 0,7$ $h/b \geq 0,5$	$c_p = 2,0$ $b/8 \leq 2 \text{ m}$
(m)	(m/s)	(kg/m ²)	(kN/m ²)	$w_p = 1,25 \times 0,8 \times q$	$w_s = 0,5 \times q$ kN/m ²	$w_s = 0,7 \times q$ kN/m ²	$w_s = 2,0 \times q$ kN/m ²
0 - 8	28,3	50	0,5	kN/m ²	0,25	0,35	1,0
8 - 20	35,8	80	0,8		0,4	0,56	1,6
20 - 100	42,0	110	1,1		0,55	0,77	2,2
> 100	45,6	130	1,3		0,65	0,91	2,6

where:

h - building height, m

b - building width, m

v - wind velocity, m/s

q - wind load, kg/m² / kN/m²

$w_{p/s}$ - wind pressure / suction, kN/m²

c_p - correction factor

Note: These values and calculations are exemplary and should not be taken into account in actual projects.

All actual calculations should be prepared and verified by qualified personnel in accordance with the relevant standards and regulations.

ALLOWABLE DEFLECTION

Allowable deflection of substructure

According to the requirements of the CWCT Standard for systemized building envelopes, at both positive and negative applications of the peak test pressure, the maximum deflection of the substructure generally should not exceed:

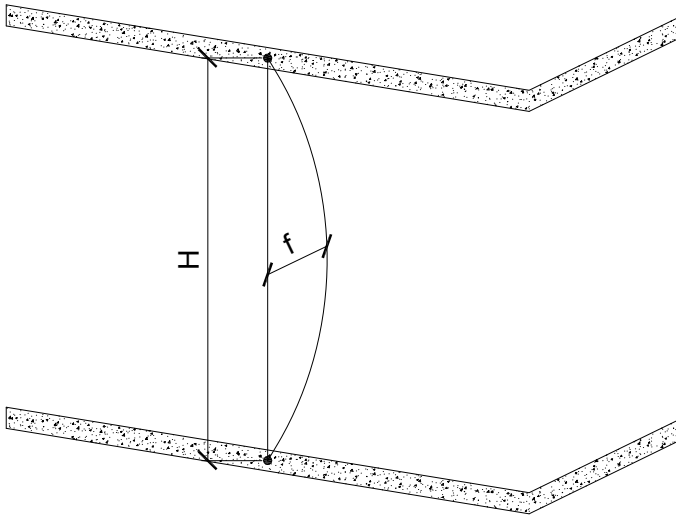

Length	Allowable deflection
$H \leq 3000 \text{ mm}$	$f \leq H/200 \text{ mm}$
$3000 \text{ mm} < H < 7500 \text{ mm}$	$f \leq 5 + H/300 \text{ mm}$
$7500 \text{ mm} \leq H$	$f \leq H/250 \text{ mm}$

Allowable deflection of some cladding materials

- Allowable deflection of **brittle materials** (e.g. plasterboard):
1/360 of the extent of the board, or 10 mm whichever is the lesser;
- Allowable deflection of **natural stone units**:
1/360 of their length measured along the stone edge, or 3 mm, whichever is the lesser (smaller) deflections may be appropriate depending on the size of stone and method of fixing;
- Allowable deflection of **rainscreen panel**:
At both positive and negative applications of the peak test pressure, the maximum deflection shall not exceed:
 - 1/90 of the span measured between the points of attachment of the panel for aluminium, glass and steel, or
 - 1/360 of the span measured between the points of attachment, or 3 mm whichever is the lesser, for stone and similar brittle materials, or
 - More restrictive limits set by the panel manufacturer.

Greater deflections may also be allowable.

N.B! The deflection limits should be agreed with the material supplier.

COMPARTMENTS

Some water may penetrate into the cavity, but the rainscreen/VFS is intended to provide protection from direct rain.

The cavity normally contains the insulation and rainscreen/VFS substructure. The volume of cavity is bounded by horizontal and vertical cavity closers, which form compartments within the cavity.

Compartmentation is necessary to:

- a) Control the airflow through cavities at corners, parapets where wind pressure varies across the surface
- b) Achieve dynamic and static pressure equalization
- c) Build an effective air barrier system, which prevent spread of fire

Compartments focus on the control of air pressure difference across the rainscreen, and the particular elements of wall assemblies instrumental in obtaining such control.

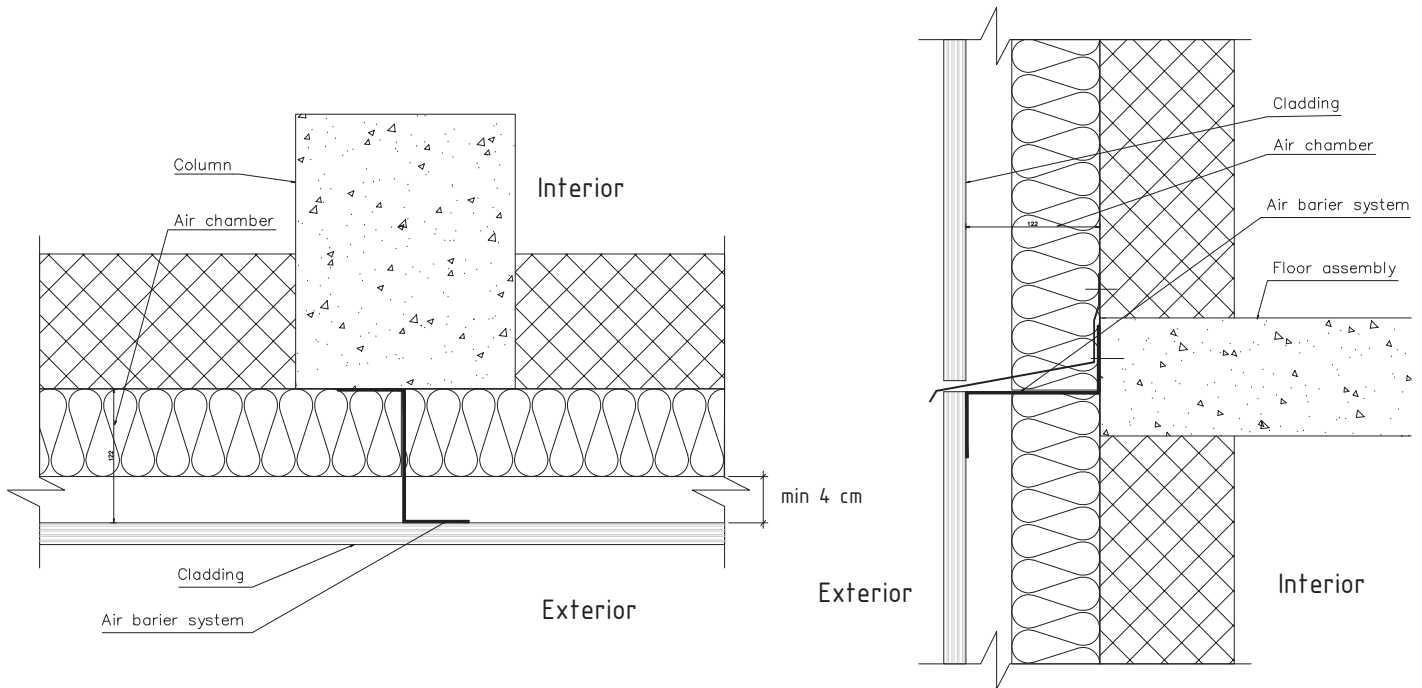

Typically, the wall assembly must comprise of three components:

- a rainscreen (i.e., vented cladding)
- a compartmented air chamber
- an air barrier system.

In General, the wall assembly must be designed to tolerate the entry of a small amount of water without damage. Preliminary studies indicate that for practical purposes, "adequate pressure equalization" for rain penetration control may be defined as not more than 25 Pa pressure differential across the rainscreen.

THERMAL PERFORMANCE

Thermal properties shall be selected in order to reduce the total in-service energy consumption of the building. These limit the levels of carbon emissions resulting from operation of the building.

Carbon emissions will be lower if the following are reduced:

- Heat transfer through the building envelope.
- Air leakage through the building envelope.
- Cooling loads arising from solar gain.

Heat transfer within an aluminum cladding system mainly affected by three highly correlated factors:

- The external cladding surface material (thermal resistance, solar and heat absorption, etc.)
- The characteristics of the air cavity between the external cladding and the main wall element (air movement, air temperature, dimensions)
- The material and characteristics of the brackets that thermally connects the exterior cladding (geometry, material, anchors) with the façade.

Breather membrane

A breather membrane may be placed on the outer face of insulation that should not be wetted. If it is acceptable for the insulation to be wetted a breather membrane may be placed behind the insulation to protect the backing wall.

A breather membrane has to withstand the full positive and negative wind loads, without tearing and without joints opening up.

Thermal bridging

The thermal bridges caused by subframe mechanical fixing devices and air spaces shall be taken into account, using the appropriate calculation method defined in EN ISO 6946 and EN ISO 10211 standards.

Particular attention shall be given to limiting thermal bridges. Thermal breaks can be used to reduce both U-value and condensation risk. To reduce the risk of condensation, thermal breaks should be placed, so as to form warm fingers and not cold fingers.

Thermostop elements serve only thermal spacers between consoles and structure.

The use of these elements in the two constructions of metal convincingly reduced heat losses and thus are suitable from the viewpoint of building physics.

Such elements (consisting of plastic or wood) are particularly effective when you want to achieve thermal resistance. $R = \left(\frac{d}{\lambda}\right)$
Where:

d is the thickness of the material layer in the component;

λ is the design thermal conductivity of the material in accordance with ISO 10456

ETEM proposes designed Therminsulation pads to separate fixing brackets from the structure. Thus, the losses are reduced, but should not be ignored because of the installed fasteners that penetrate the solid wall element.

The characteristics of the bracket are of great importance, since the bracket penetrates the insulation protection and creates a three-dimensional thermal bridge. The contact area between the bracket and the solid wall is a significant factor in thermal losses due to point thermal bridges.

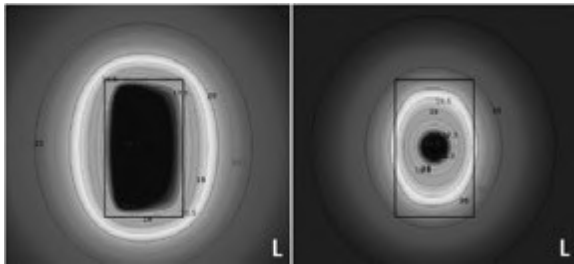

without thermal brake

with thermal brake

THERMAL RESISTANCE OF HOMOGENEOUS LAYER

The principle of the calculation method is as follows:

- To obtain the thermal resistance of thermally homogenous part of the component;
- To combine these individual resistances so as to obtain the total thermal resistance of the component, including the effect of surface resistances.

The total thermal resistance, R_T of a plane building component consisting of thermally homogeneous layers, perpendicular to the heat flow shall be calculated by the following expression:

$$R_T = R_i + R_1 + R_2 + \dots R_n + R_e$$

where

R_i is the internal surface resistance;

R_1, R_2, \dots, R_n are the design thermal resistances of each layer;

R_e is the external surface resistance.

Thermal transmittance (U-values)

Calculation of U-value of a zone of the building envelope shall be calculated using the weighted U-value method. The thermal transmittance is given by

$$U = \frac{1}{R_T}$$

The calculation shall be carried out as described below.

- a) Calculate R_e as the total thermal resistance of the component excluding the tapered layer, using above equation if all layers are thermally homogenous.
- b) Subdivide the area with tapered layers into individual parts, as necessary.
- c) Calculate R_1 and R_2 for each tapered layer, using

$$R_1 = \frac{d_1}{\lambda_1}$$

$$R_2 = \frac{d_2}{\lambda_2}$$

- d) Calculate the thermal transmittance of each individual part U_i in accordance with the relevant equation
- e) Calculate the overall thermal transmittance for the whole area using

$$U = \frac{\sum U_i A_i}{\sum A_i}$$

If total thermal resistance of a component with tapered layers is required, then

$$R_T = \frac{1}{U}$$

Example: U-value calculation of thermally homogeneous VFS layers

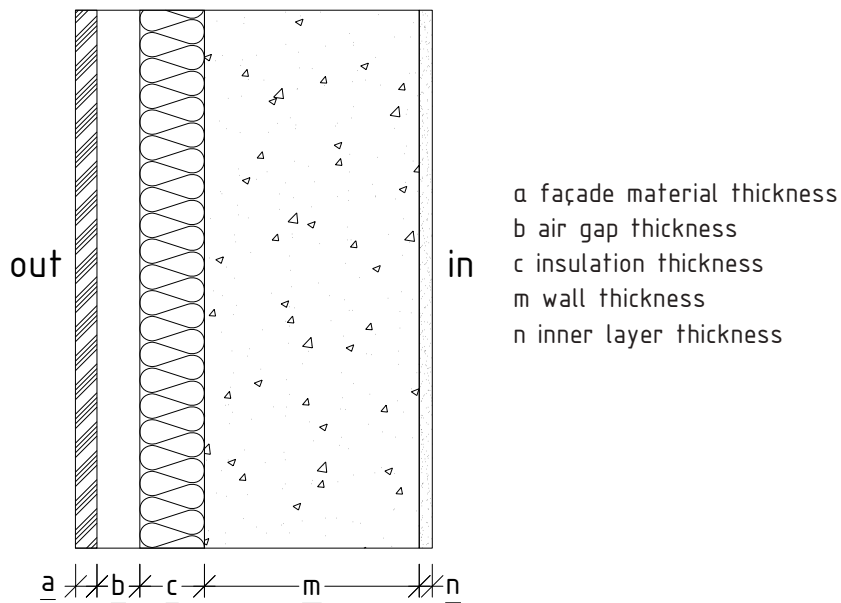

if	a	ceramic tile thickness is	0,015 m
	b	air gap thickness is	0,05 m
	c	insulation thickness is	0,08 m
	m	brick wall thickness is	0,25 m
	n	plaster thickness is	0,02 m

then

$$1/U = 1/R_e + \sum d/\lambda + 1/R_i$$

$$1/U = 0,05 + 0,015/0,064 + 0,05/0,025 + 0,08/0,05 + 0,25/0,44 + 0,02/0,9 + 0,13 = 4,605$$

U = 0,217 W/m²K

where	U	thermal transmittance (W/m ² K)
	1/R _e	external surface transmittance (W/m ² K)
	d	layer thickness (m)
	λ	design thermal conductivity (W/mK)
	1/R _i	internal surface transmittance (W/m ² K)
	R	design thermal resistance (m ² K/W)

Note: This is a simplified method. For a more comprehensive calculation method, see EN ISO 6946:2007 *Building components and building elements - Thermal resistance and thermal transmittance - Calculation method* (ISO 6946:2007).

DIMENSIONING OF MAIN SUPPORTING PROFILE

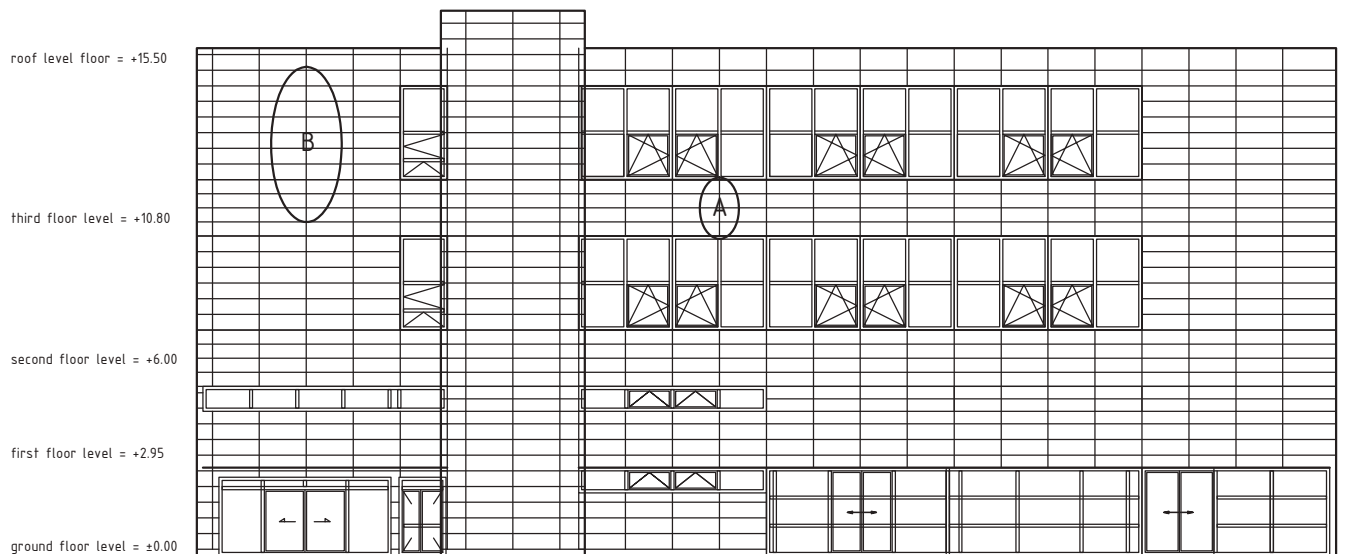

Initial data:

Project = Office building
Building location = Plovdiv, Bulgaria
Structure base = concrete/brick
Type of façade material = etalbond®
Cladding system = BRAVO W

Façade height = 15.5 m
Floor height = 4.80 m
Length of the main profile = 4.80 m
Thermal insulation: mineral batt = 80 mm

Façade raster = 1500x500 mm
Distance between main profiles = 1500 mm
Distance between fixing brackets = 1616 mm
Fixing brackets = ET 710011.00 - 100 mm

Loads:

Façade material weight = 5.5 kg/m²
Wind load (normative) = 0.41 kN/m²

CHOOSING THE APPROPRIATE FIXING BRACKET

Simply supported beam with one fixed and one movable support - area A

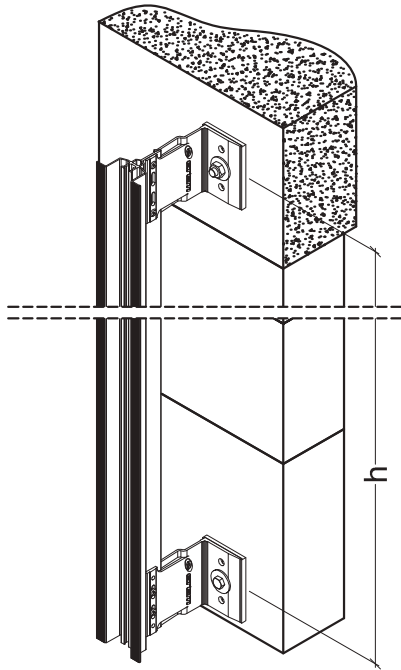

- wind load
- dead load
- fixed support
- movable support

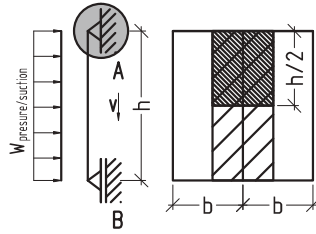

Fixed support

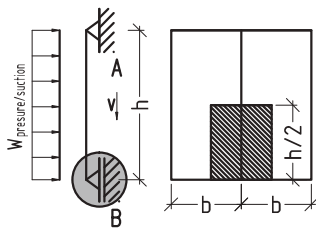

Movable support

Fixed support

- Self weight - dead load
 $V = g \cdot 3h \cdot b$

For determining the maximum permissible wind load the following formulae apply:

- Wind load-pressure
 $W_p = f_1 \cdot q \cdot c_p \cdot h/2 \cdot b$

- Wind load-suction
 $W_s = q \cdot c_p \cdot h/2 \cdot b$

where:

V - load, kN

g - weight of main vertical profiles and façade material, kN/m²

W_p - wind pressure, kN

W_s - wind suction, kN

k_z - correction factor (height)

q - dynamic load, kN/m²

c_p - correction factor (wind pressure)

h - distance between fixing brackets, m

b - distance between main vertical profiles, m

H - building height, m

Movable support

For determining the maximum permissible wind load the following formulae apply:

- Wind load-pressure
 $W_p = f_1 \cdot q \cdot c_p \cdot h/2 \cdot b$

- Wind load-suction
 $W_s = q \cdot c_p \cdot h/2 \cdot b$

Example

Initial data:

H = 0-15 m (middle zone)

g = 0,41 kN/m²

f₁ = 1,25

q = 0,5 kN/m²

c_p = 0,8 (wind pressure)

c_p = -0,5 (wind suction)

h = 1,828 m

b = 1,5 m

- Own weight - dead load

$$V = g \cdot h \cdot b = 0,065 \cdot 1,828 \cdot 1,5 = 0,178 \text{ kN}$$

- Wind load

$$W_p = f_1 \cdot q \cdot c_p \cdot h/2 \cdot b = 1,25 \cdot 0,41 \cdot 0,8 \cdot 0,914 \cdot 1,5 = 0,562 \text{ kN}$$

$$W_s = q \cdot c_p \cdot h/2 \cdot b = 0,41 \cdot (-0,6) \cdot 0,914 \cdot 1,5 = (-0,337) = 0,337 \text{ kN}$$

- Wind load

$$W_p = f_1 \cdot q \cdot c_p \cdot h/2 \cdot b = 1,25 \cdot 0,41 \cdot 0,8 \cdot 0,914 \cdot 1,5 = 0,562 \text{ kN}$$

$$W_s = q \cdot c_p \cdot h/2 \cdot b = 0,41 \cdot (-0,6) \cdot 0,914 \cdot 1,5 = (-0,337) = 0,337 \text{ kN}$$

Finally, we choose the appropriate fixing bracket with greater bearing capacity than the calculated value.

Fixing bracket for fixed support must bear both calculated values for dead load and wind load.

Fixing bracket for movable support must bear just wind load.

All static calculations must be verified by a responsible structural/façade engineer on site.

CHOOSING THE APPROPRIATE FIXING BRACKET

Continuous supported beam with one fixed and three movable supports – area B

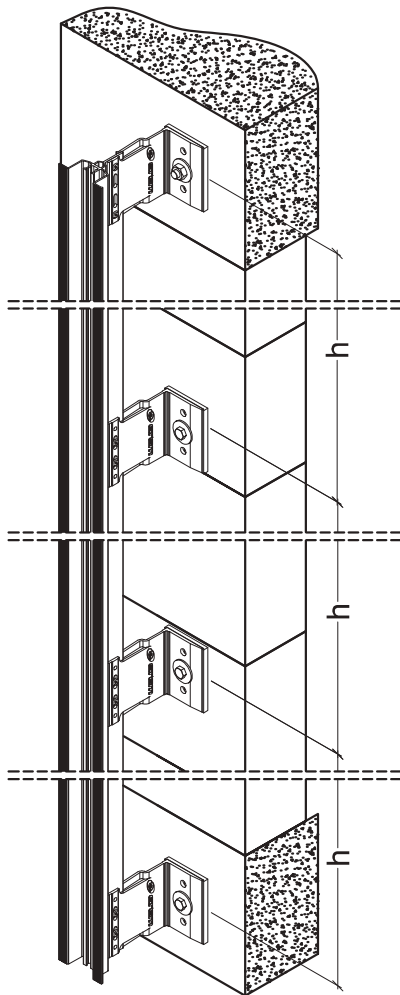

- wind load
- dead load
- A** fixed support
- B** movable support

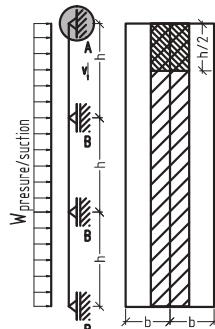

Fixed support

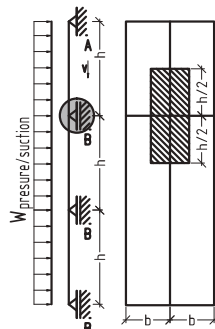

Movable support (middle)

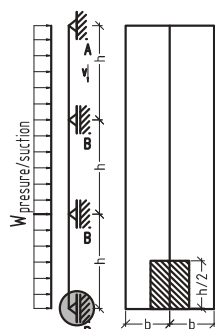

Movable support (end)

Fixed support

- Self weight – dead load
 $V = g \cdot 3h \cdot b$

For determining the maximum permissible wind load the following formulae apply:

- Wind load-pressure
 $W_p = f_1 \cdot q \cdot c_p \cdot h/2 \cdot b$

- Wind load-suction
 $W_s = q \cdot c_p \cdot h/2 \cdot b$

where:

- V – load, kN
- g – weight of main vertical profiles and façade material, kN/m²
- W_p – wind pressure, kN
- W_s – wind suction, kN
- κ_z – correction factor (height)
- q – dynamic load, kN/m²
- c_p – correction factor (wind pressure)
- h – distance between fixing brackets, m
- b – distance between main vertical profiles, m
- H – building height, m

Movable support (middle)

For determining the maximum permissible wind load the following formulae apply:

- Wind load-pressure
 $W_p = f_1 \cdot q \cdot c_p \cdot h \cdot b$

- Wind load-suction
 $W_s = q \cdot c_p \cdot h \cdot b$

Example

- Initial data:
 H = 0–15 m (middle zone)
 g = 0.065 kN/m²
 f₁ = 1,25
 q = 0,41 kN/m²
 c_p = 0,8 (wind pressure)
 c_p = -0,6 (wind suction)
 h = 1,616 m
 h/2 = 0,808 m
 b = 1,5 m

- Own weight – dead load

$$V = g \cdot 3h \cdot b = 0,065 \cdot 4,85 \cdot 1,5 = 0,472 \text{ kN}$$

- Wind load

$$W_p = f_1 \cdot q \cdot c_p \cdot h/2 \cdot b = 1,25 \cdot 0,41 \cdot 0,8 \cdot 0,808 \cdot 1,5 = 0,496 \text{ kN}$$

$$W_s = q \cdot c_p \cdot h/2 \cdot b = 0,41 \cdot (-0,6) \cdot 0,808 \cdot 1,5 = 0,298 \text{ kN}$$

- Wind load

$$W_p = f_1 \cdot q \cdot c_p \cdot h \cdot b = 1,25 \cdot 0,41 \cdot 0,8 \cdot 1,616 \cdot 1,5 = 0,994 \text{ kN}$$

$$W_s = q \cdot c_p \cdot h \cdot b = 0,41 \cdot (-0,6) \cdot 1,616 \cdot 1,5 = (-0,596) = 0,596 \text{ kN}$$

Movable support (end)

For determining the maximum permissible wind load the following formulae apply:

- Wind load-pressure
 $W_p = f_1 \cdot q \cdot c_p \cdot h/2 \cdot b$
- Wind load-suction
 $W_s = q \cdot c_p \cdot h/2 \cdot b$

- Wind load

$$W_p = f_1 \cdot q \cdot c_p \cdot h/2 \cdot b = 1,25 \cdot 0,41 \cdot 0,8 \cdot 0,808 \cdot 1,5 = 0,497 \text{ kN}$$

$$W_s = q \cdot c_p \cdot h/2 \cdot b = 0,41 \cdot (-0,6) \cdot 0,808 \cdot 1,5 = (-0,298) = 0,298 \text{ kN}$$

Finally we choose the appropriate fixing bracket with bigger bearing capacity than the calculated value.

Fixing bracket for fixed support must bear both calculated values for dead load and wind load.

Fixing bracket for movable support must bear just wind load.

All static calculations must be verified by a responsible structural/façade engineer on site.

DIMENSIONING OF MAIN SUPPORTING PROFILE



BRAVO W – ventilated façade system for hanging etalbond® and ENF®:

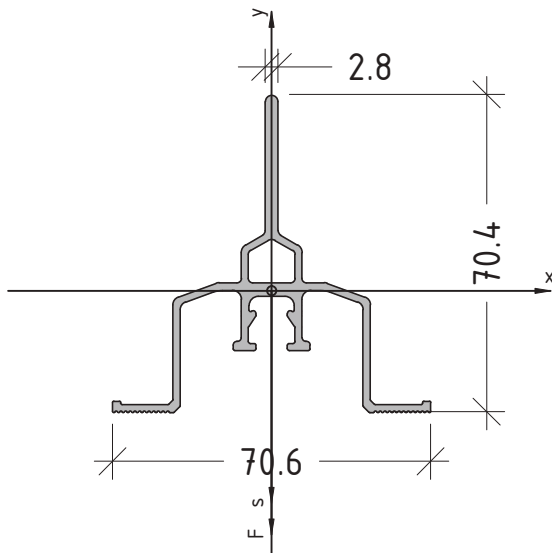

Profile characteristics:

profile code – E97101
standard length – 6,01 m
weight of the profile – 1103g/m
material – aluminum EN AW 6060 T66
Yield point – 160N/mm²
Young's Modulus – 70000N/mm²

Geometrical characteristics:

moment of inertia

$$I_x = 13.249\text{cm}^4$$

$$I_y = 8.896\text{cm}^4$$

section modulus

$$W_x = 3.039\text{cm}^3$$

$$W_y = 2.250\text{cm}^3$$

area

$$A = 4.069\text{cm}^2$$

All static calculations must be verified by a responsible structural/façade engineer on site.

DIMENSIONING OF MAIN SUPPORTING PROFILE

Simply supported beam with one fixed and one movable supports – area A

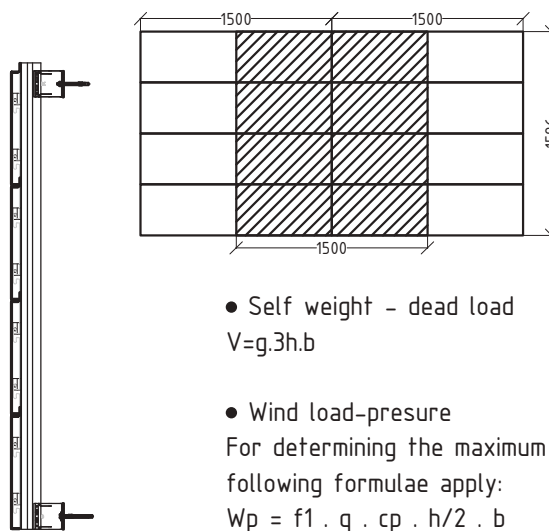
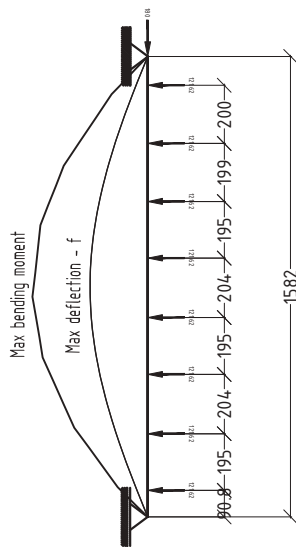

- Self weight – dead load
 $V = g \cdot 3h \cdot b$

- Wind load–pressure
For determining the maximum permissible wind load the following formulae apply:
 $Wp = f1 \cdot q \cdot cp \cdot h/2 \cdot b$

- Wind load–suction
 $Ws = q \cdot cp \cdot h/2 \cdot b$

where:
 V – load, kN
 g – weight of main vertical profiles and façade material, kN/m²
 Wp – wind pressure, kN
 Ws – wind suction, kN
 f1 – correction factor
 q – dynamic load, kN/m²
 cp – correction factor (wind pressure)
 h – distance between fixing brackets, m
 b – distance between main vertical profiles, m
 H – building height, m
 s – distance between fixing brackets

Dimensioning of profile E97101

Initial data:

H = 0–15 m (middle zone)
 g = 0.065 kN/m²
 f1 = 1,25
 q = 0,41 kN/m²
 cp = 0,8 (wind pressure)
 cp = - 0,6 (wind suction)
 h = 1.828 m
 b = 1,5 m
 s = 1.828 m

Defining the loads:

- Self weight – dead load

$$V = g \cdot 3h \cdot b = 0,066 \cdot 1.828 \cdot 1,5 = 0.180 \text{ kN}$$

- Wind load of the profile area

$$Wp = f1 \cdot q \cdot cp \cdot h \cdot b = 1,25 \cdot 0,41 \cdot 0,8 \cdot 1,582 \cdot 1,5 = 0,973 \text{ kN}$$

$$Ws = q \cdot cp \cdot h \cdot b = 0,41 \cdot (-0,6) \cdot 1,582 \cdot 1,5 = (-0,584) = 0,584 \text{ kN}$$

$$F = Wp / \text{quantity of the hangers}$$

$$F = 0,973 / 8 = 0,122 \text{ kN} = 121,6 \text{ N}$$

Permissible deflection:

$$[f] = s / 200$$

$$[f] = 1582 / 200 = [7,91 \text{ mm}]$$

Results of the calculation

$$\text{Max deflection} = 5,41 \text{ mm} < [7,91 \text{ mm}]$$

$$\text{Max Stress} = 62,949 \text{ N/mm}^2 < [160 \text{ N/mm}^2]$$

$$\text{Max bending moment} = 191,29 \text{ Nm}$$

$$\text{Safety Factor} = 2,5417 > [2]$$

Conclusion:

Based on the conditions above, profile E97101 provides the necessary bearing capacity.

The calculation was made using Autocad Mechanical static module.

Application point of the force F from the wind load on the profile is physically the hanger.
 All static calculations must be verified by a responsible structural/façade engineer on site.

DIMENSIONING OF MAIN SUPPORTING PROFILE

Continuous beam with one fixed and three movable supports – area B

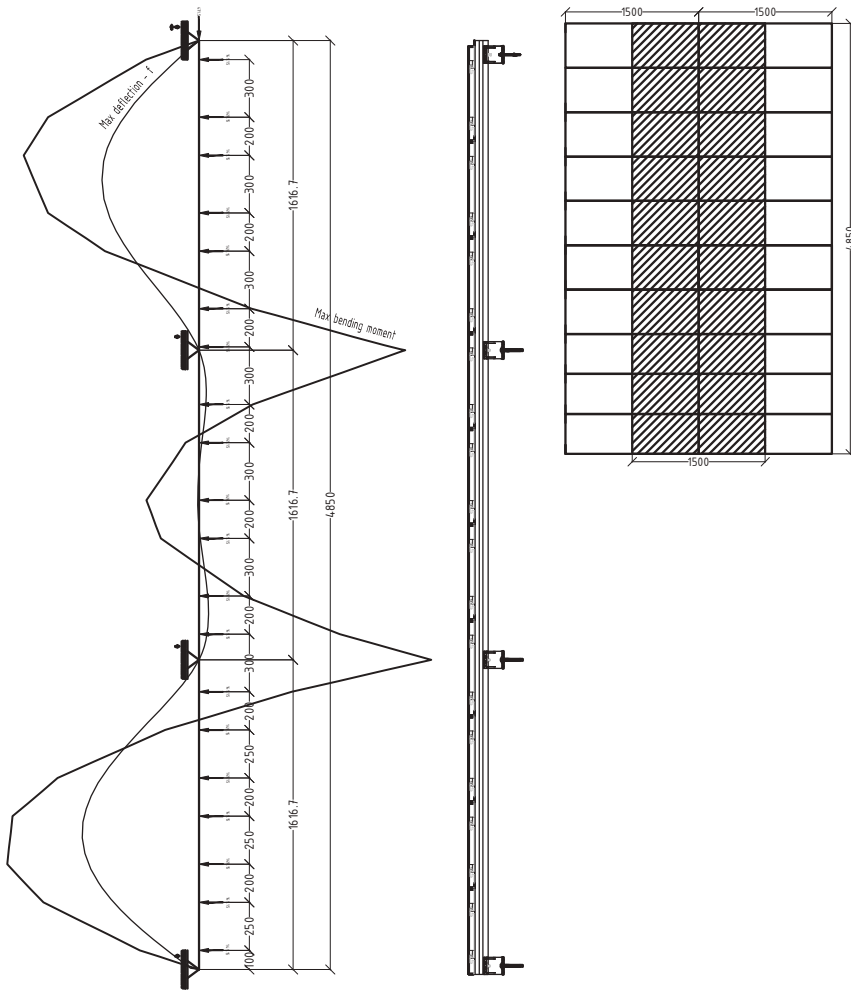

- Own weight - dead load
 $V = g \cdot 3h \cdot b$

- Wind load-pressure
For determining the maximum permissible wind load the following formulae apply:
 $Wp = f1 \cdot q \cdot cp \cdot h/2 \cdot b$

- Wind load-suction
 $Ws = q \cdot cp \cdot h/2 \cdot b$

where:

- V - load, kN
- g - weight main vertical profiles and façade material, kN/m²
- Wp - wind pressure, kN
- Ws - wind suction, kN
- f1 - correction factor
- q - dynamic load, kN/m²
- cp - correction factor (wind pressure)
- h - distance between fixing brackets, m
- b - distance between main vertical profiles, m
- H - building height, m
- s - distance between fixing brackets

Dimensioning of profile E97101

Initial data:

- H = 0-15 m (middle zone)
- g = 0.065 kN/m²
- f1 = 1,25
- q = 0,41 kN/m²
- cp = 0,8 (wind pressure)
- cp= - 0,6 (wind suction)
- h = 4.85 m
- b = 1,5 m
- s = 1.616 m

Defining the loads:

- Own weight - dead load
 $V = g \cdot 3h \cdot b = 0,065 \cdot 4,85 \cdot 1,5 = 0,472 \text{ kN}$
- Wind load of the profile area
 $Wp = f1 \cdot q \cdot cp \cdot h \cdot b = 1,25 \cdot 0,41 \cdot 0,8 \cdot 4,85 \cdot 1,5 = 2,983 \text{ kN}$
 $Ws = kz \cdot q \cdot cp \cdot h \cdot b = 0,41 \cdot (-0,6) \cdot 4,85 \cdot 1,5 = (-1,342) = 1,789 \text{ kN}$

$$F = Wp/\text{quantity of the hangers}$$

$$F = 2,983/20 = 0,149 \text{ kN} = 149,1 \text{ N}$$

- Permissible deflection:
[f] = s/200
[f]= 1616/200 = [8.08mm]

Results of the calculation

- Max deflection = 3,45 mm < [8.08 mm]
- Max Stress = 55,924N/mm² < [160N/mm²]
- Max bending moment = 169,94 Nm
- Safety Factor = 2,8610 > [2]

Conclusion:

Based on the conditions above, profile E97101 provides the necessary bearing capacity.

The calculation was made using AutoCad Mechanical deflection line module.

Application point of the force F from the wind load on the profile is physically the hanger.
All static calculations must be verified by a responsible structural/façade engineer on site.

FIXING BRACKETS AND ACCESSORIES

E TEM FIXING BRACKETS

ET710008.00

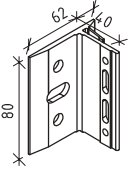

ET710010.00

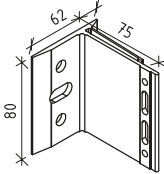

ET710011.00

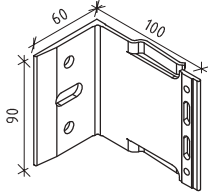

ET710013.00

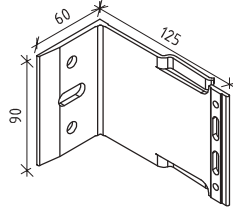

ET710012.00

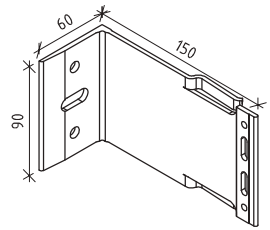

ET710014.00

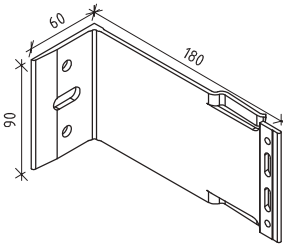

ET710015.00

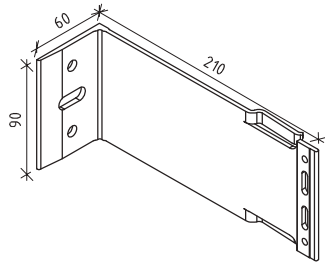

ET710016.00

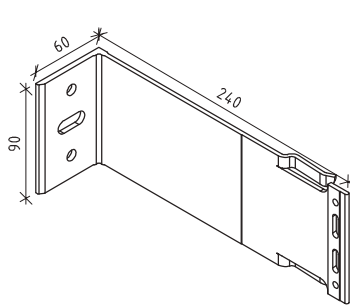

ET710038.00

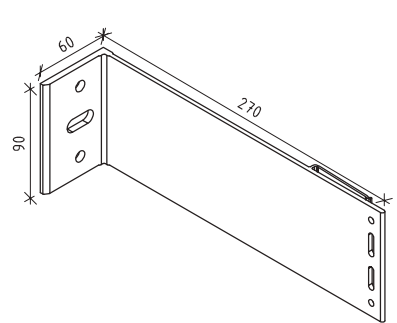

ET710001.00

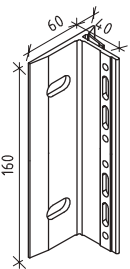

ET710002.00

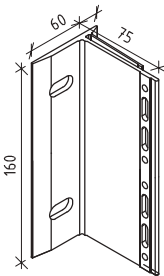

ET710003.00

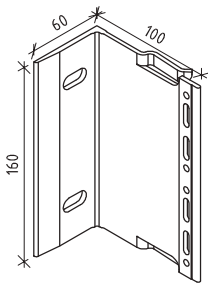

ET710004.00

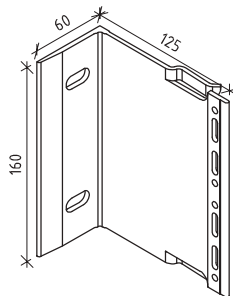

ET710005.00

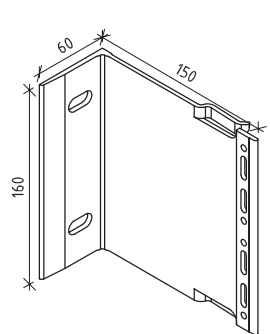

ET710006.00

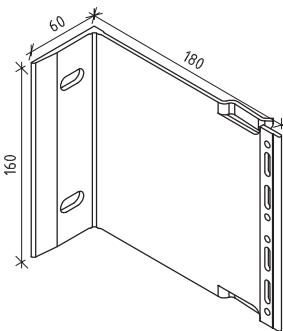

ET710007.00

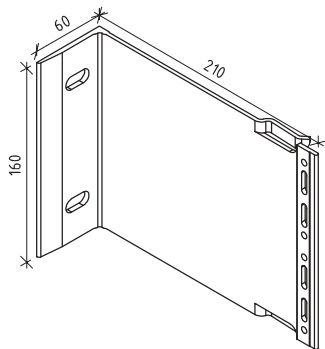

ET710017.00

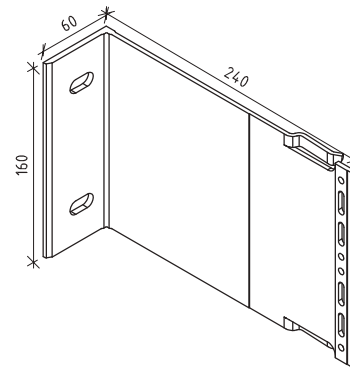

ET710039.00

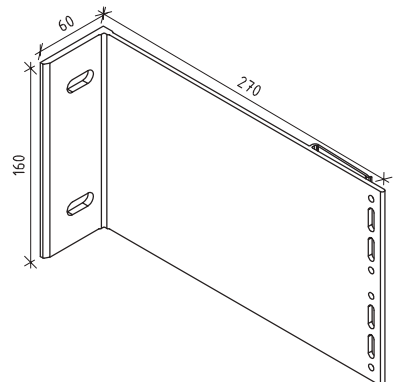

ETEM FIXING BRACKETS & THERMO INSULATION PADS

Fixing brackets					Suitable Thermo pads
Code	Type	A (mm)	B (mm)	C (mm)	Type
ET710008.00	single	80	60	40	ET730031.00 single
ET710010.00	single	80	60	75	
ET710011.00	single	90	60	100	ET730033.00 double
ET710013.00	single	90	60	125	
ET710012.00	single	90	60	150	
ET710014.00	single	90	60	180	
ET710015.00	single	90	60	210	
ET710016.00	single	90	60	240	
ET710038.00	single	90	60	270	

Single fixing bracket

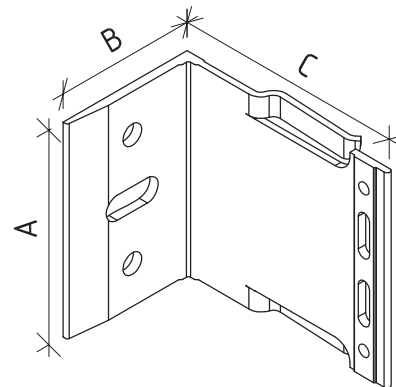

Fixing brackets					Suitable Thermo pads
Code	Type	A (mm)	B (mm)	C (mm)	Type
ET710001.00	double	160	60	40	ET730032.00 single
ET710002.00	double	160	60	75	
ET710003.00	double	160	60	100	ET730034.00 double
ET710004.00	double	160	60	125	
ET710005.00	double	160	60	150	
ET710006.00	double	160	60	180	
ET710007.00	double	160	60	210	
ET710017.00	double	160	60	240	
ET710039.00	double	160	60	270	

Double fixing bracket

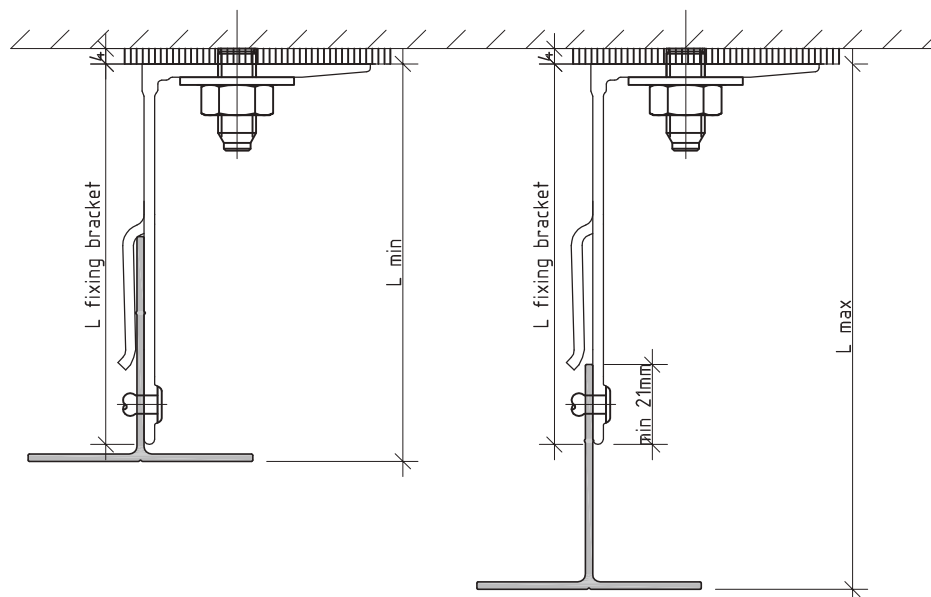
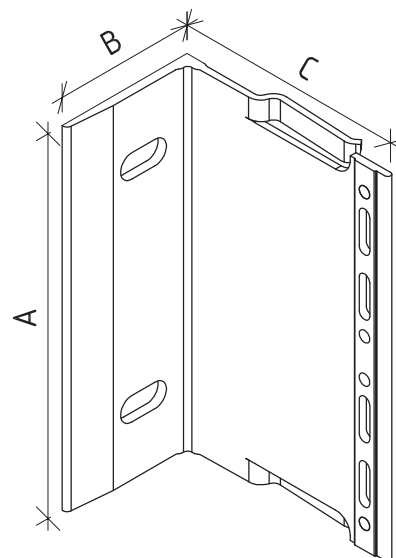

ETEM's fixing brackets allow to distance the cladding material from the backing wall from min 68mm up to max 312mm with 60mm T profile
It's possible to adjust the profile up to 33mm (Lmin to Lmax).

FIXING BRACKETS AND ACCESSORIES







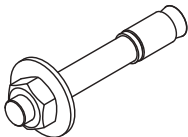

The performance characteristics of all ETEM fixing brackets is tested in laboratory conditions for the worst case scenario.

The aim of the test is to determine the load bearing capacity and wind resistance of the brackets and their fixings to the subframe under tension and shear loads.

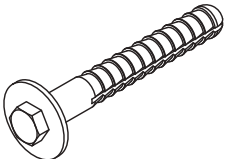
Summary of results from testing of brackets for ETEM VFS systems

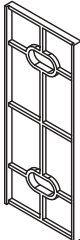
Code	Type	Size(mm)	Support	Loading direction	Loadbearing capacity	
					At elastic behavior of material (without residual displacement)	At displacement 2 mm
ET710001.00 (07vario072)	double	62/40/160	fixed	vertical	6,40 kN	14,45 kN
ET710002.00 (07vario082)	double	62/75/160	fixed	horizontal	6,07 kN	10,86 kN
ET710002.00 (07vario082)	double	62/75/160	movable	horizontal	5,04 kN	10,95 kN
ET710002.00 (07vario082)	double	62/75/160	fixed	vertical	6,04 kN	10,33 kN
ET710003.00 (07varioQ102)	double	60/100/160	fixed	vertical	4,65 kN	7,03 kN
ET710003.00 (07varioQ102)	double	60/100/160	fixed	horizontal	1,45 kN	6, 38 kN
ET710005.00 (07varioQ152)	double	60/150/160	fixed	vertical	3,67 kN	5,03 kN
ET710004.00 (07varioQ172)	double	60/125/160	fixed	vertical	3,42 kN	6,67 kN
ET710004.00 (07varioQ172)	double	60/125/160	fixed	horizontal	5,17 kN	10,93 kN
ET710004.00 (07varioQ172)	double	60/125/160	movable	horizontal	7,15 kN	10,15 kN
ET710014.00 (07varioQ18)	single	60/180/90	fixed	vertical	0,38 kN	0,46 kN
ET710006.00 (07varioQ182)	double	60/180/160	fixed	vertical	2,40 kN	3,32 kN
ET710015.00 (07varioQ21)	single	60/210/90	fixed	vertical	0,36 kN	0,41 kN
ET710015.00 (07varioQ21)	single	60/210/90	fixed	horizontal	1,37 kN	3,11 kN
ET710015.00 (07varioQ21)	single	60/210/90	movable	horizontal	1,65 kN	3,04 kN
ET710007.00 (07varioQ212)	double	60/210/160	fixed	vertical	2,15 kN	2,67 kN
ET710007.00 (07varioQ212)	double	60/210/160	fixed	horizontal	7,23 kN	10,21 kN
ET710007.00 (07varioQ212)	double	60/210/160	movable	horizontal	8,30 kN	11,45 kN

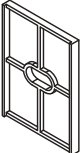
NOTE: All codes in brackets are the old ones!

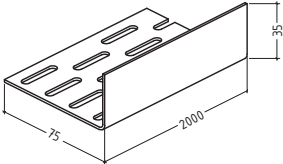
code description		package/pcs	code description		package/pcs
ET740002.00 ET740003.00 anchor		100	ET740022.00 ET740023.00 ET740024.00 rivet		1000
ET740004.00 ET740005.00 plug anchor		100	ET740041.00 screw		250
ET740019.00 bolt		1000	ET730032.00 for brackets height 45-75 mm ET730034.00 for brackets height 100-270 mm thermo insulation pad double		280 700
ET740028.00 nut		1000	ET730031.00 for brackets height 45-75 mm ET730033.00 for brackets height 100-270 mm thermo insulation pad single		500 1000
ET740001.00 washer		1000	ET710022.00 joint profile		200
ET740023.00 ventilation grating		pcs 1			

SYSTEMS

BRAVO / VARIO / FORTE



BRAVO

BRAVO W / BRAVO U / BRAVO Y / BRAVO H



BRAVO W

BRAVO W IS THE OPTIMAL SOLUTION FOR LARGE AND FLAT FAÇADES, ENSURING FAST AND SECURE INSTALLATION OF CASSETTES FROM ALUMINIUM COMPOSITE MATERIALS (etalbond®) AND METAL SHEETS. THE SYSTEM ALLOWS THE MOVEMENT OF THE FAÇADE MATERIAL, DUE TO VARIOUS THERMAL EXPANSIONS, WITHOUT COMPROMISING THE SECURE ATTACHMENT OF THE CASSETTES.

MAIN ADVANTAGES:

- fast and secure installation
- hangers, allowing adjustment in three directions to facilitate the installation of the cassettes

CLADDING MATERIALS: Aluminium Composite Material, Metal sheet products.

code	profile	weight length moment of inertia	code	profile	weight length moment of inertia
E 97101 main profile		1103 g/m L=6.01 m Ix=14.25 cm ⁴ Iy=8.90 cm ⁴	E 97105 U profile		248 g/m L=6.01 m
E 97102 main profile		1329 g/m L=6.01 m Ix=37.52 cm ⁴ Iy=8.90 cm ⁴	ET720061.00 hanger		pcs 1
E 97104 F profile		394 g/m L=6.01 m	ET710068.00 supporting profile 190x40mm		pcs 1
			ET710069.00 supporting profile 64x64x20mm		pcs 1

note: goes along with accessory ET740041.00

note: placed in the middle of the cassette and depends on its size and applied loads

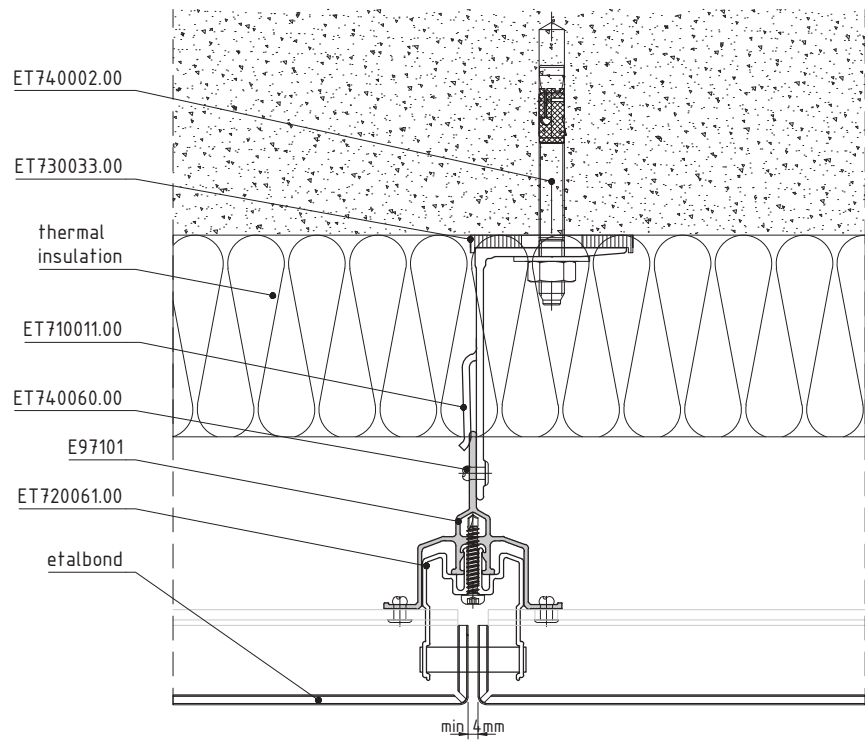
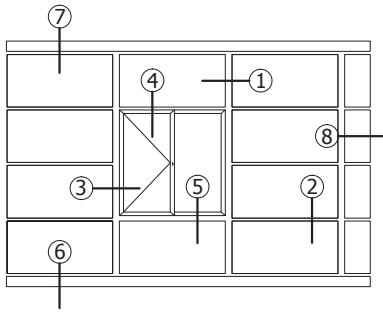

①

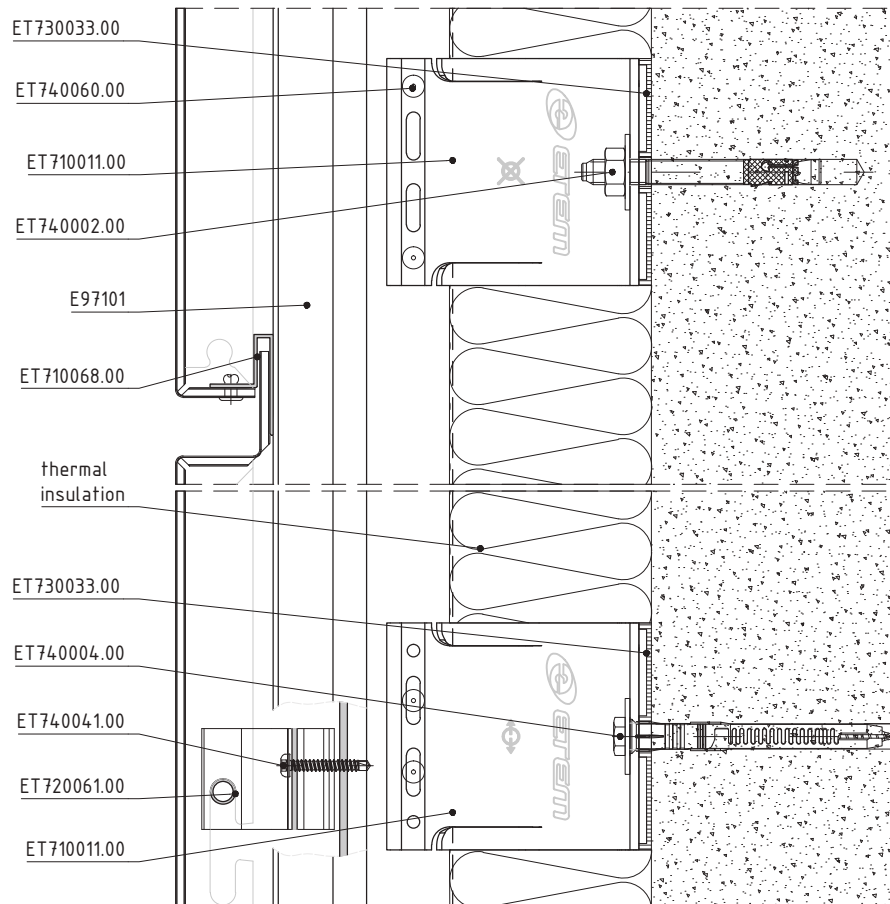

②

3

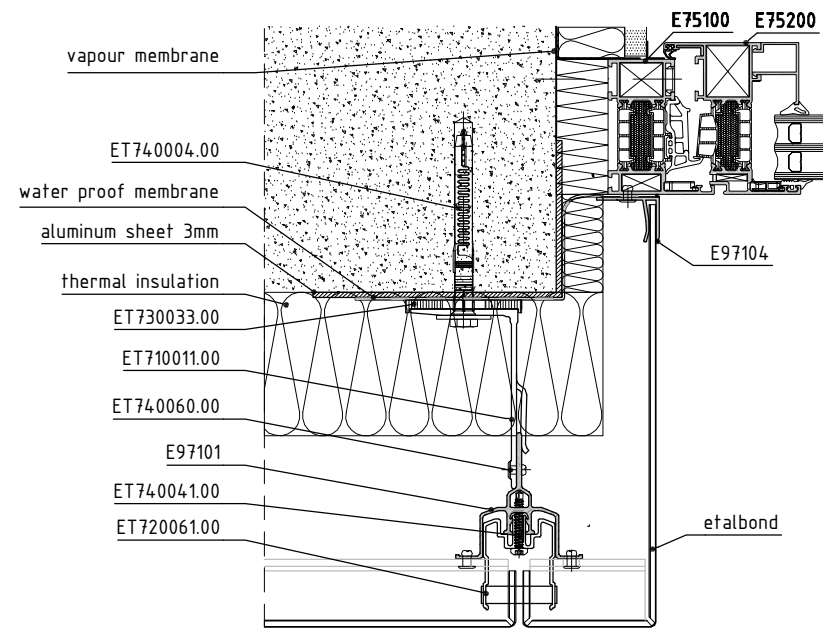

4

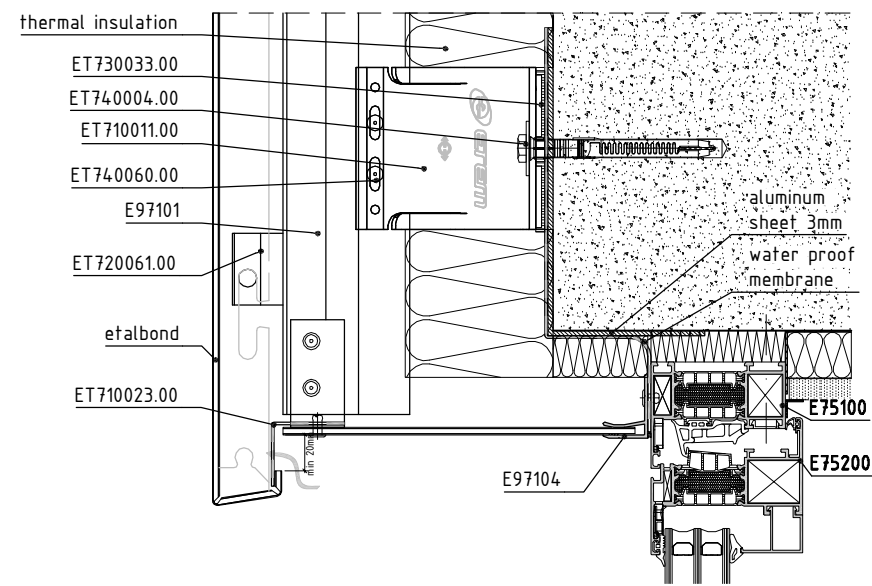

5

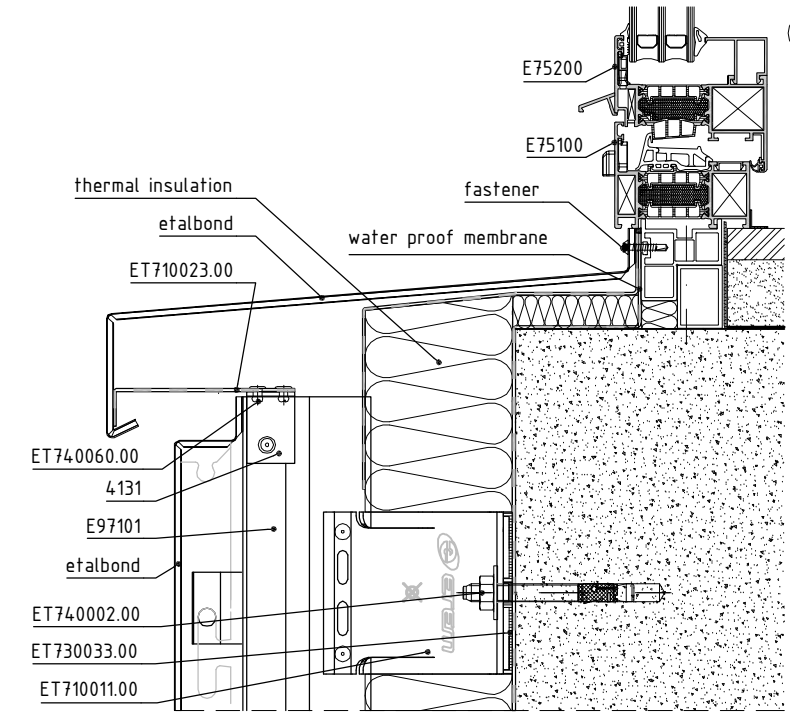

6

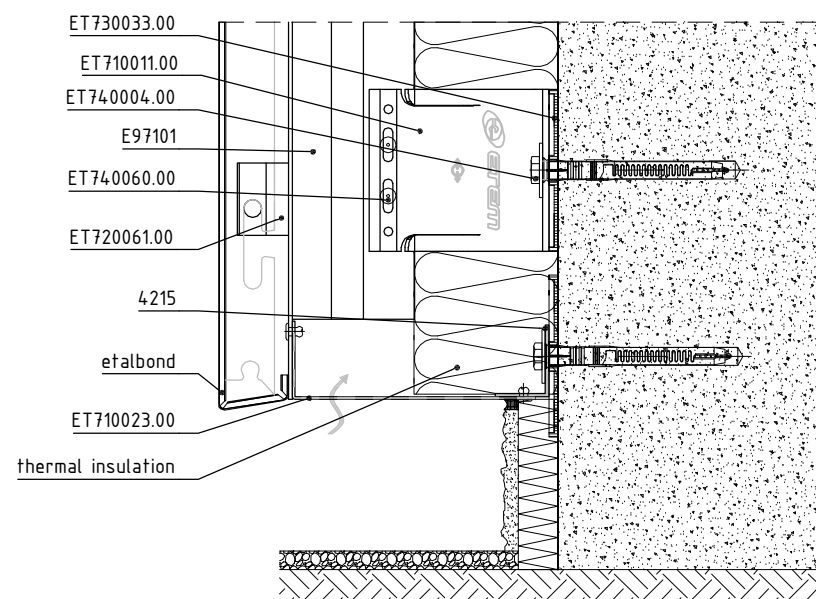

7

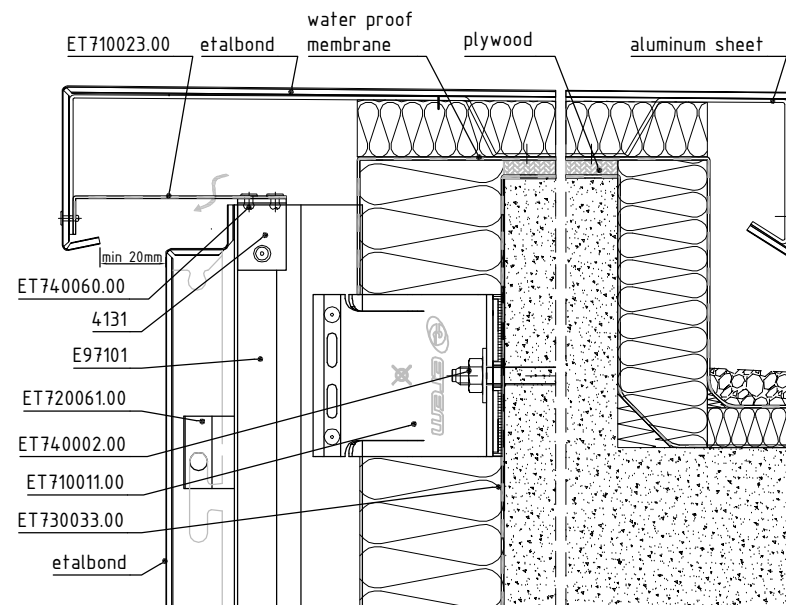

8

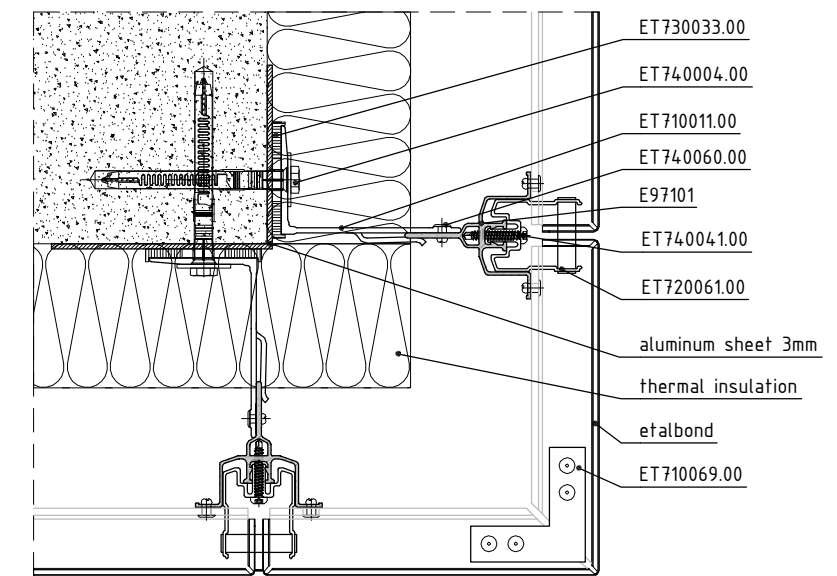

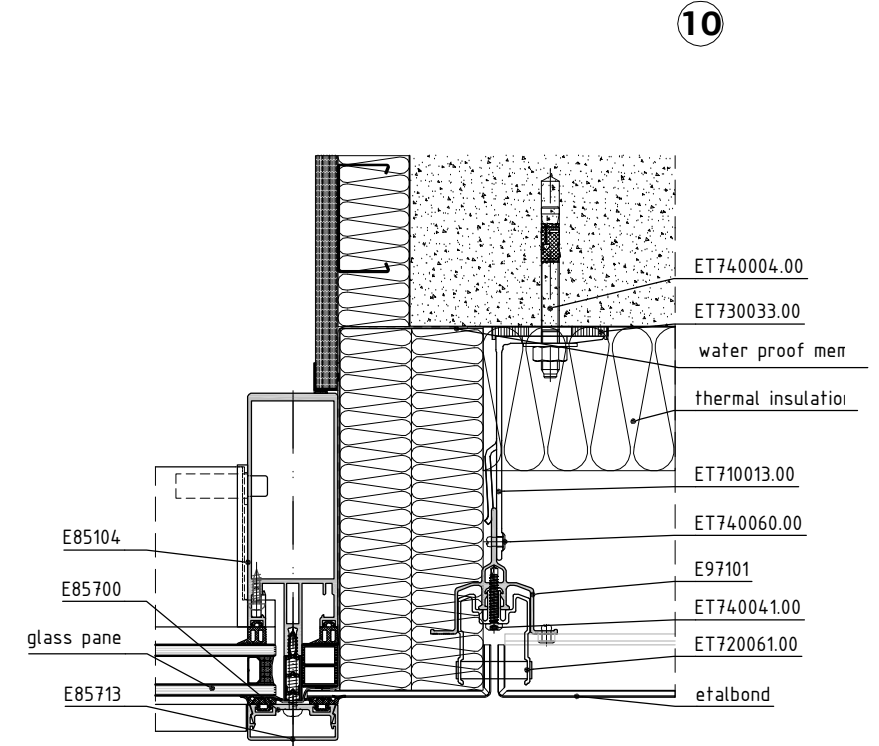
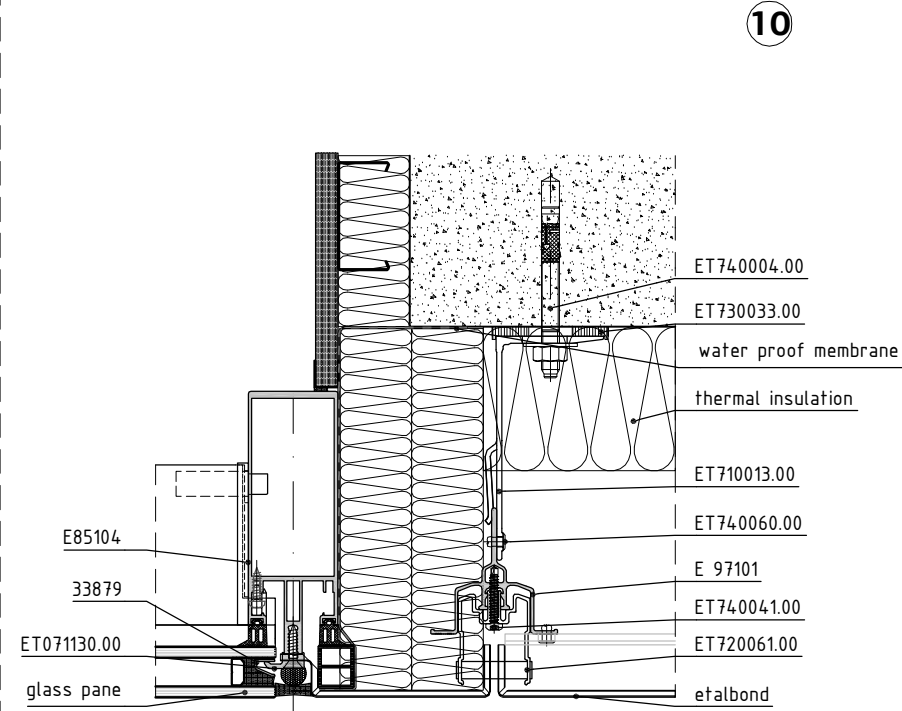
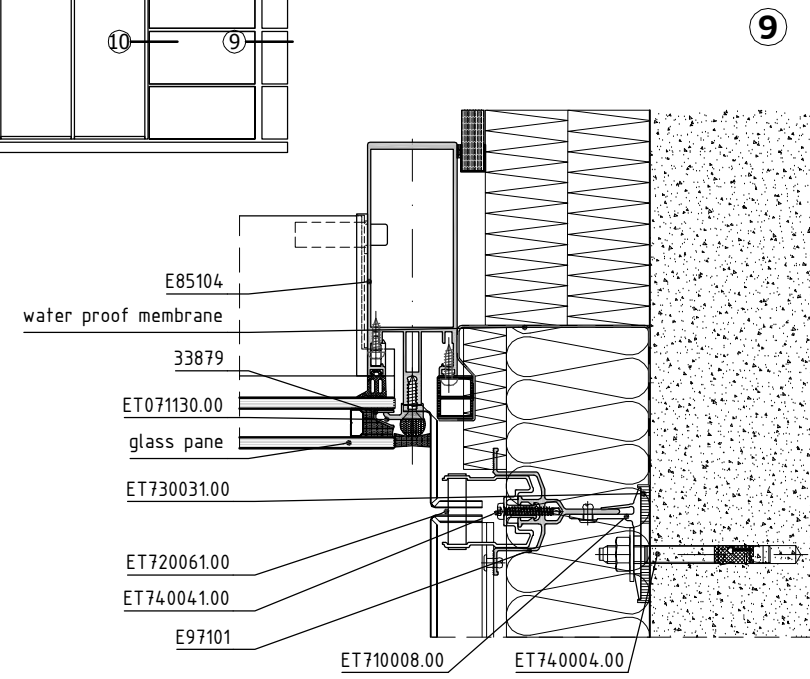
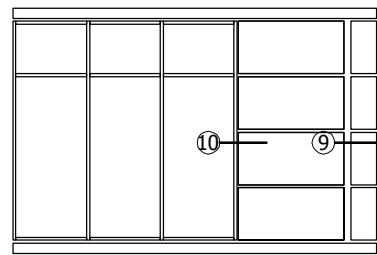



BRAVO U

BRAVO U IS A SYSTEM FOR INSTALLATION OF COMPOSITE MATERIALS AND METAL SHEETS, USING THE MOST SUCCESSFUL PRINCIPLE OF PANEL HANGING. THE SYSTEM IS AN OPTIMAL SOLUTION FOR LARGE AND FLAT FAÇADES. IT ENSURES FAST AND SECURE INSTALLATION OF THE COMPOSITE PANELS AND IT IS AN OPTIMAL RESPONSE TO THE THERMAL EXPANSION OF THE MATERIAL.

MAIN ADVANTAGES:

- U- shaped brackets
- profiles, allowing the implementation of curved ventilated façades
- hangers, allowing adjustment in three projections to facilitate the installation of the composite material panels

CLADDING MATERIALS: Aluminium Composite Material, Metal sheet products.

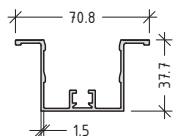
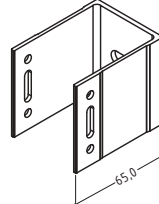
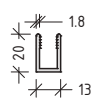
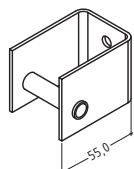
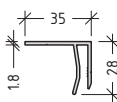
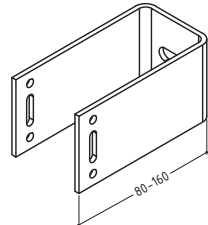
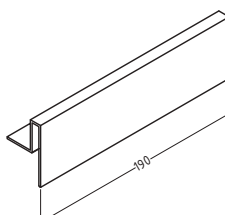
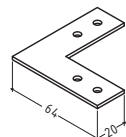
code	profile	weight length moment of inertia	code	profile	weight length moment of inertia
E 97103 main profile		761 g/m L=6.01 m $I_x=10.94 \text{ cm}^4$ $I_y=5.67 \text{ cm}^4$	ET710060.00 wall bracket		pcs 1
			note: the same size bracket, could be produced from aluminium sheet		
E 97105 U profile		248 g/m L=6.01 m	ET720060.00 hanger		pcs 1
			note: goes along with accessories ET740019.00 and ET740028.00		
E 97104 F profile		394 g/m L=6.01 m	ET710061.00 - 80mm ET710062.00 - 120mm ET710063.00 - 160mm ET710065.00 - 100mm ET710066.00 - 140mm wall bracket		pcs 1
ET710068.00 supporting profile 190x40mm		pcs 1	ET710069.00 supporting profile 64x64x20mm		pcs 1
note: placed in the middle of the cassette and depends on its size and applied loads					

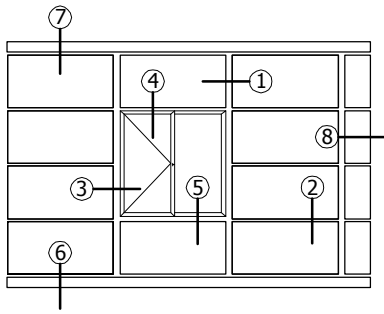

①

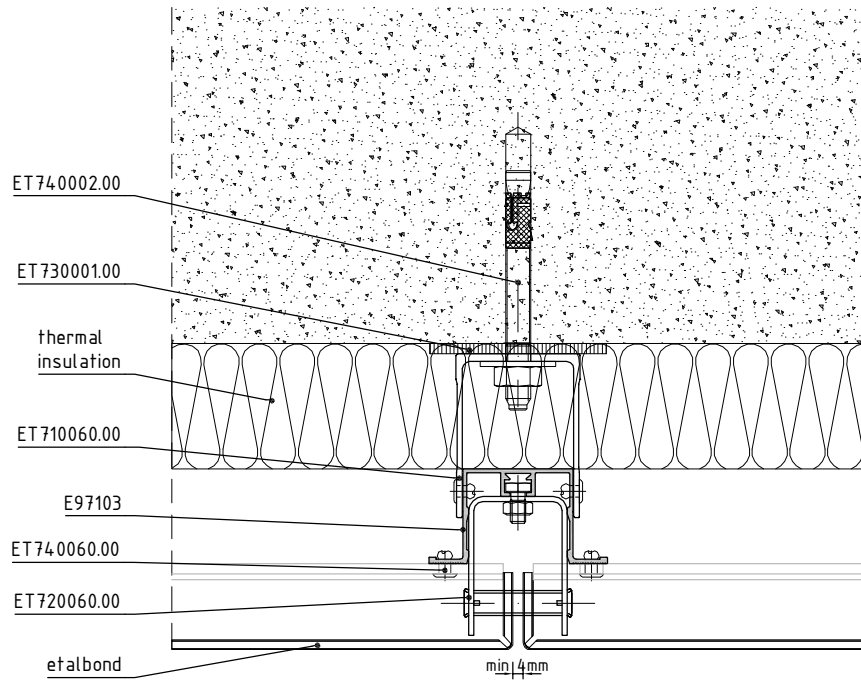

②

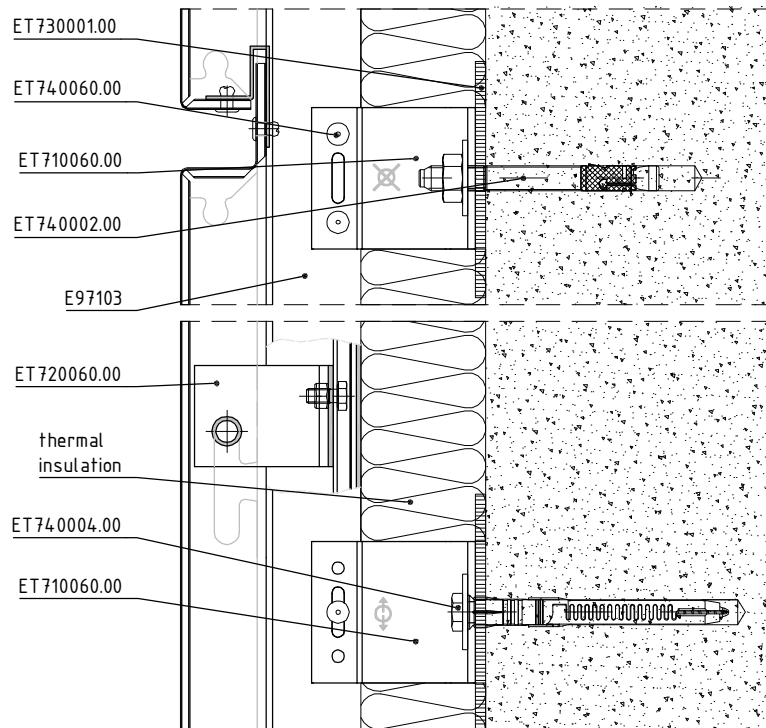

3

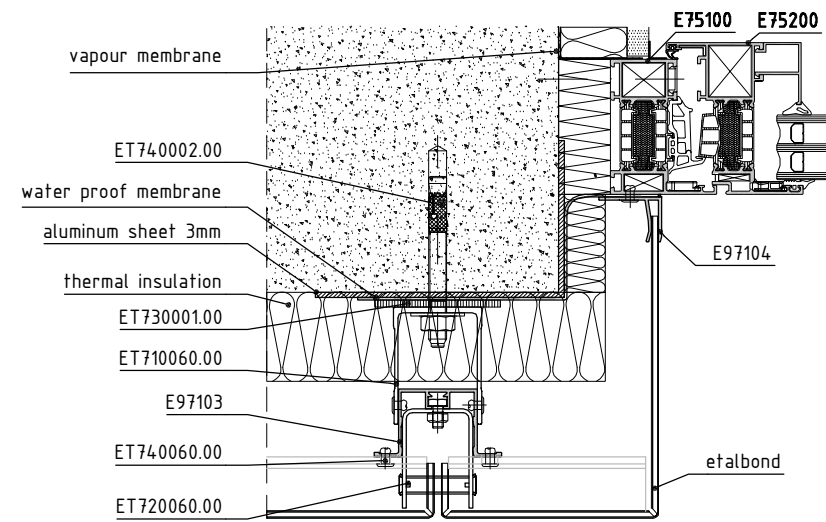

4

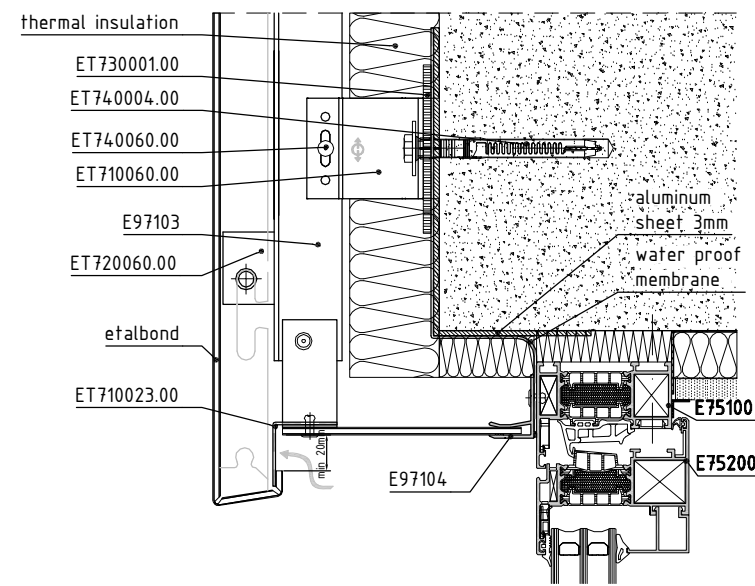

5

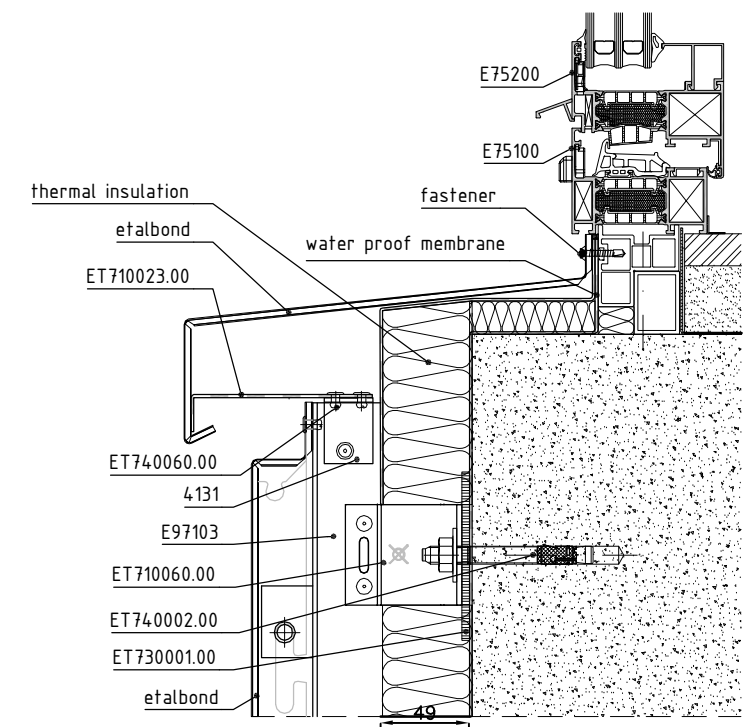

6

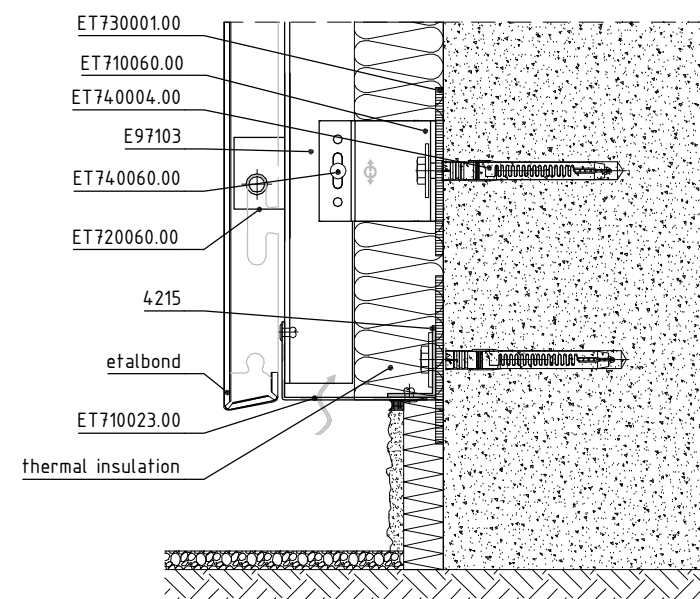

7

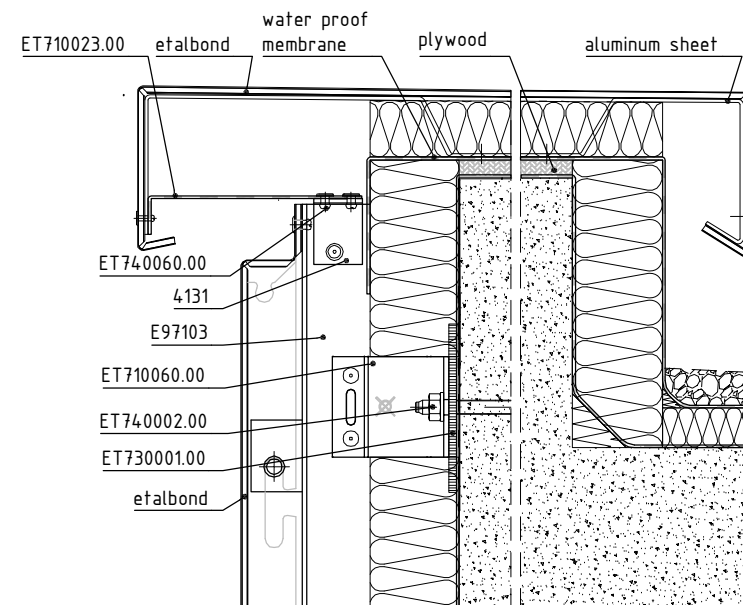

8

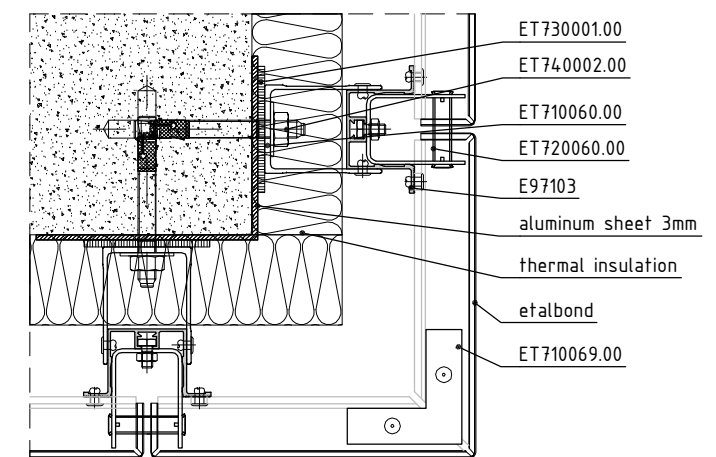

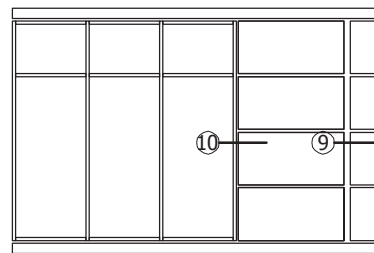

9

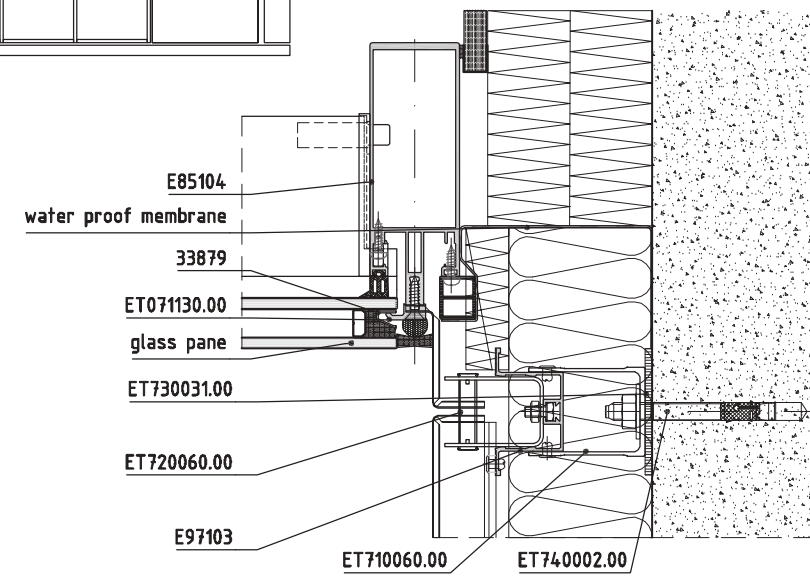

10

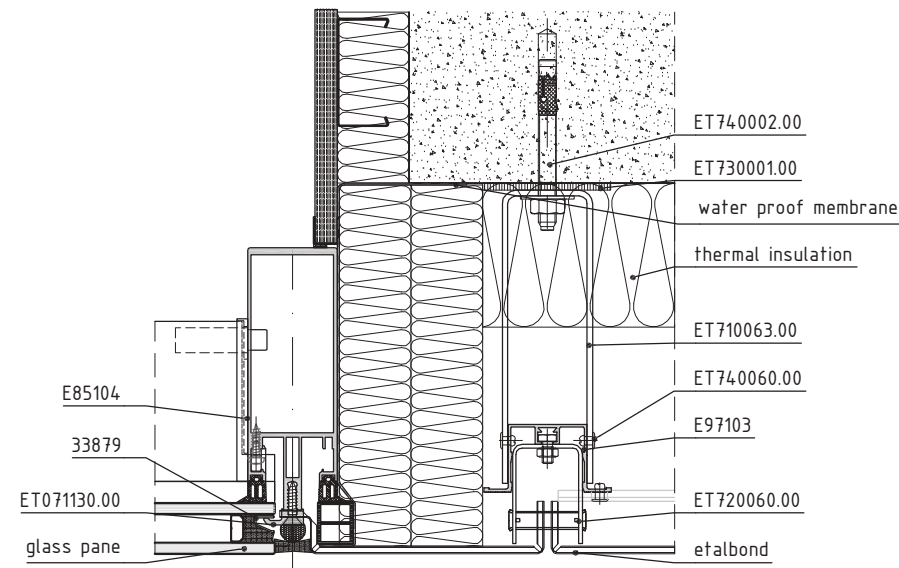

10

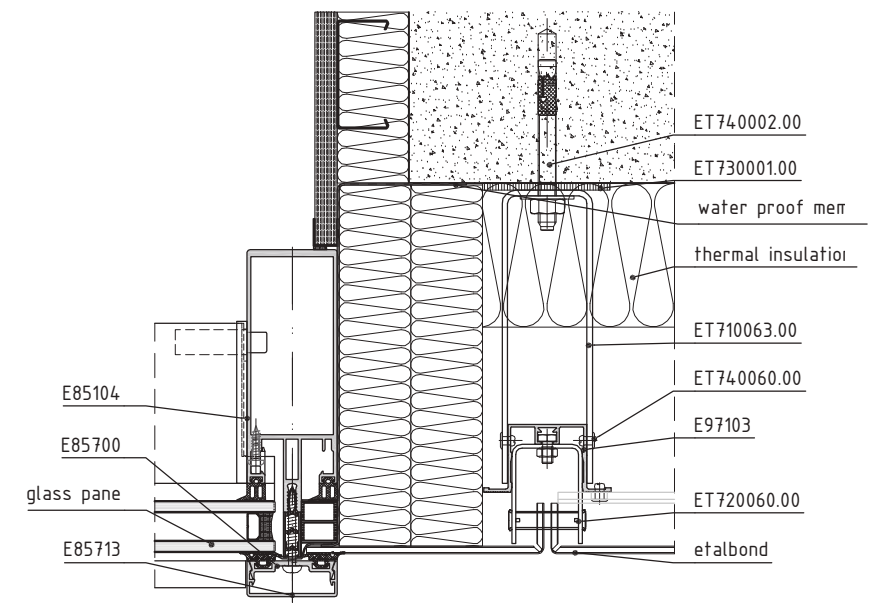





BRAVO Y

SYSTEM IS DESIGNED FOR INSTALLATION OF COMPOSITE MATERIALS AND METAL SHEETS, BY USING THE MOST SUCCESSFUL PRINCIPLE OF CLADDING. THE SYSTEM IS AN OPTIMAL SOLUTION FOR LARGE AND FLAT FAÇADES.

MAIN ADVANTAGES:

- fast and secure installation
- hangers, allowing adjustment in three projections to facilitate the installation of the panels
- specially designed hangers which do not require machining of holes for hanging the panels
- precision engineered "Y" slot on each hanger

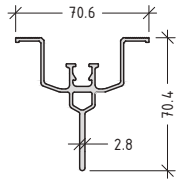
CLADDING MATERIALS: Aluminium Composite Material, Metal sheet products.

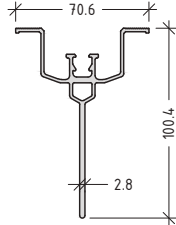
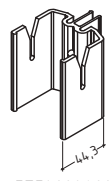
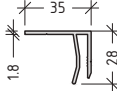
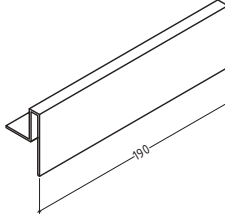
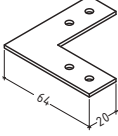
code	profile	weight length moment of inertia	code	profile	weight length moment of inertia
E 97101 main profile		1103 g/m L=6.01 m $I_y=13.25 \text{ cm}^4$ $I_x=8.90 \text{ cm}^4$	E 97105 U profile		248 g/m L=6.01 m
E 97102 main profile		1329 g/m L=6.01 m $I_y=37.52 \text{ cm}^4$ $I_x=8.90 \text{ cm}^4$	ET720062.00 hanger		pcs 1
E 97104 F profile		394 g/m L=6.01 m	ET710068.00 supporting profile 190x40mm		pcs 1
			ET710069.00 supporting profile 64x64x20mm		pcs 1

note: goes along with accessory ET740041.00

note: placed in the middle of the cassette and depends on its size and applied loads

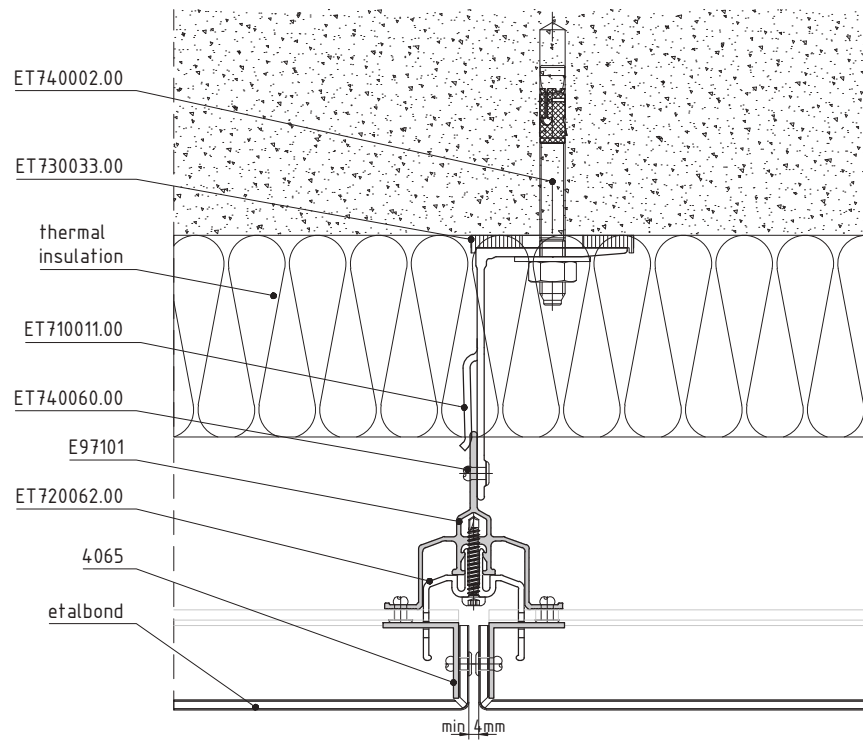
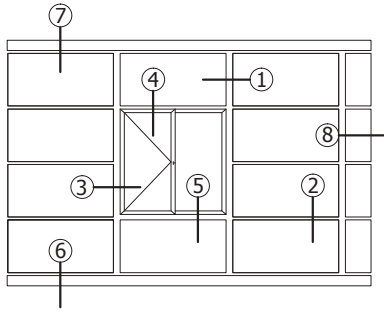

①

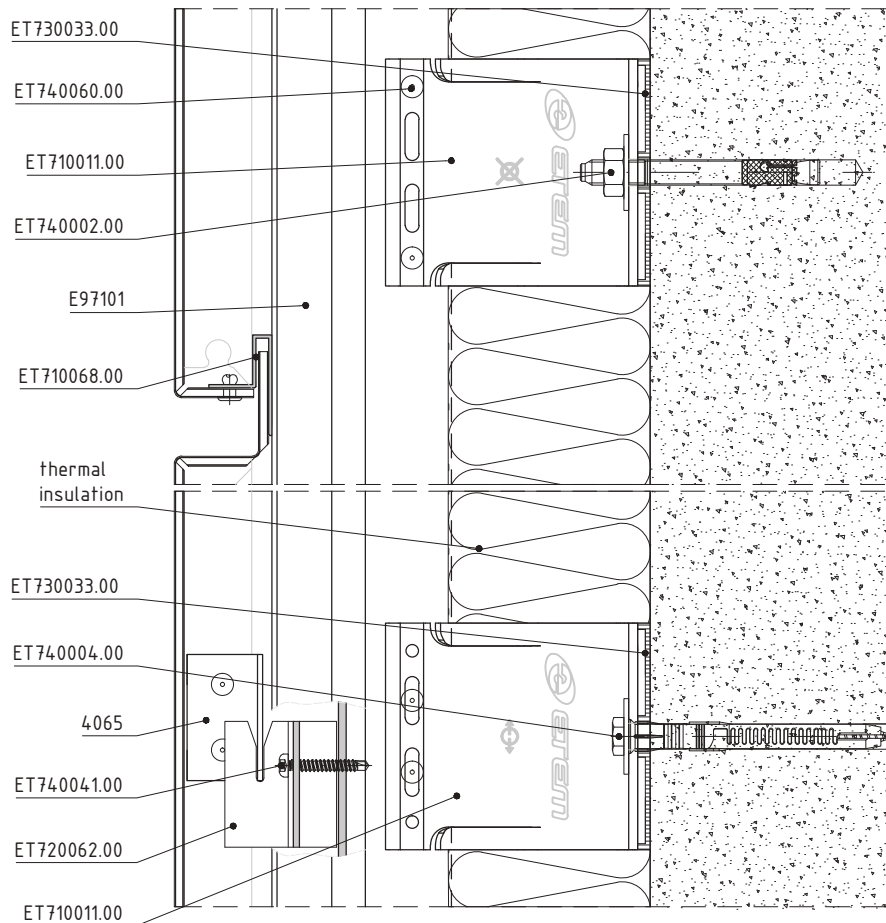

②

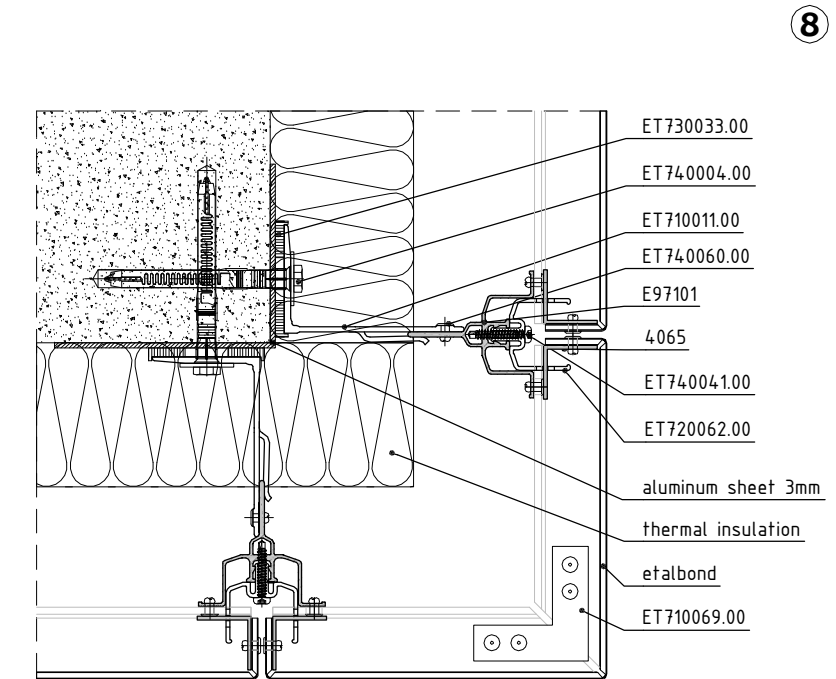
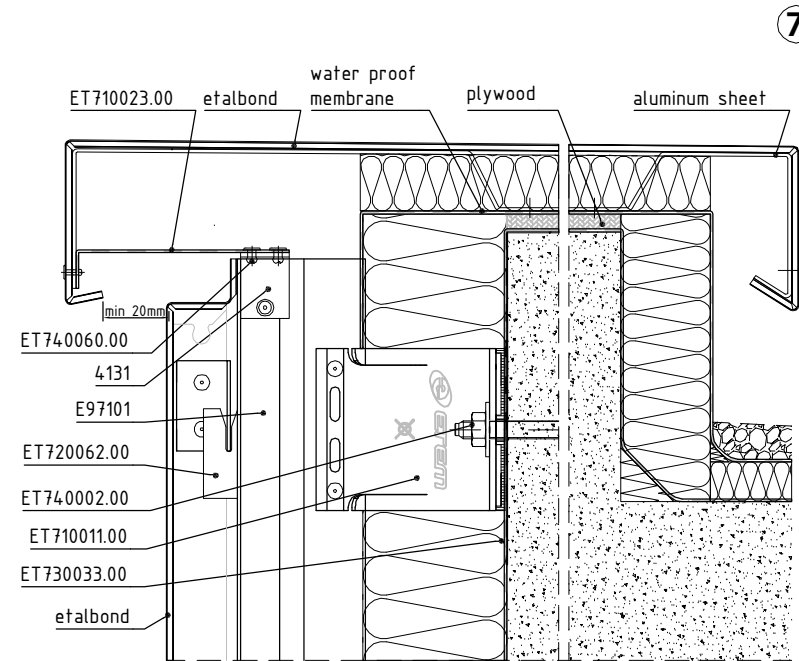
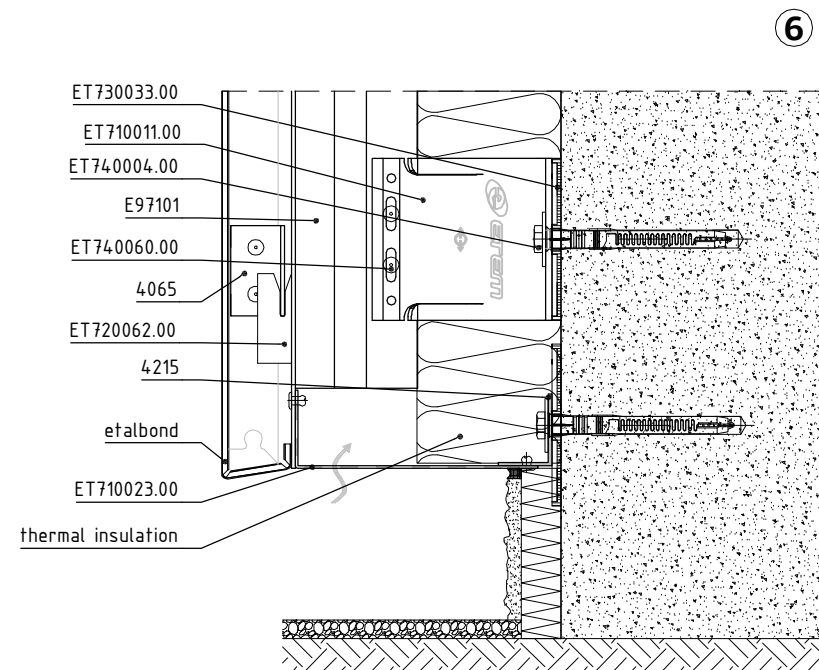
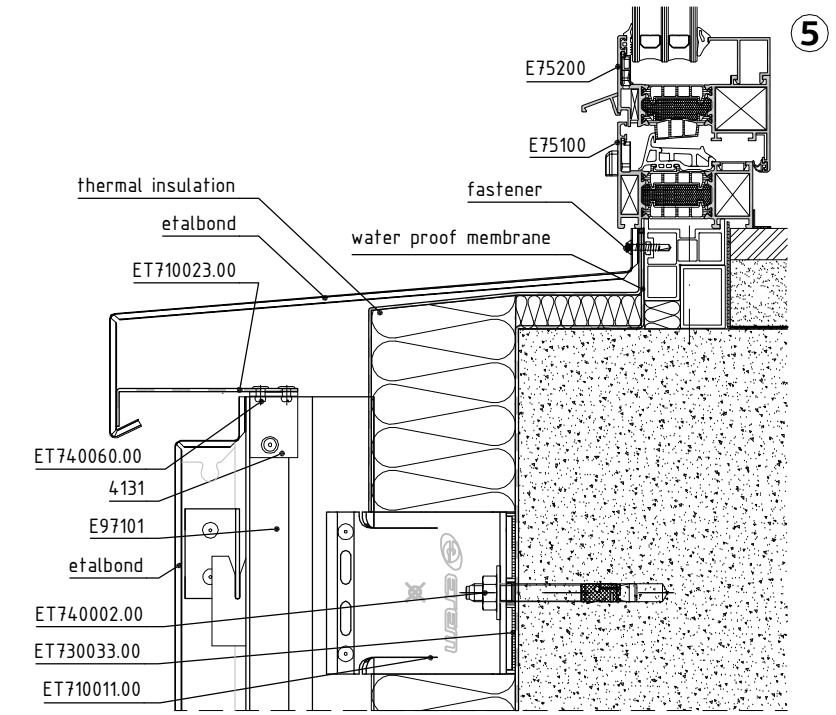
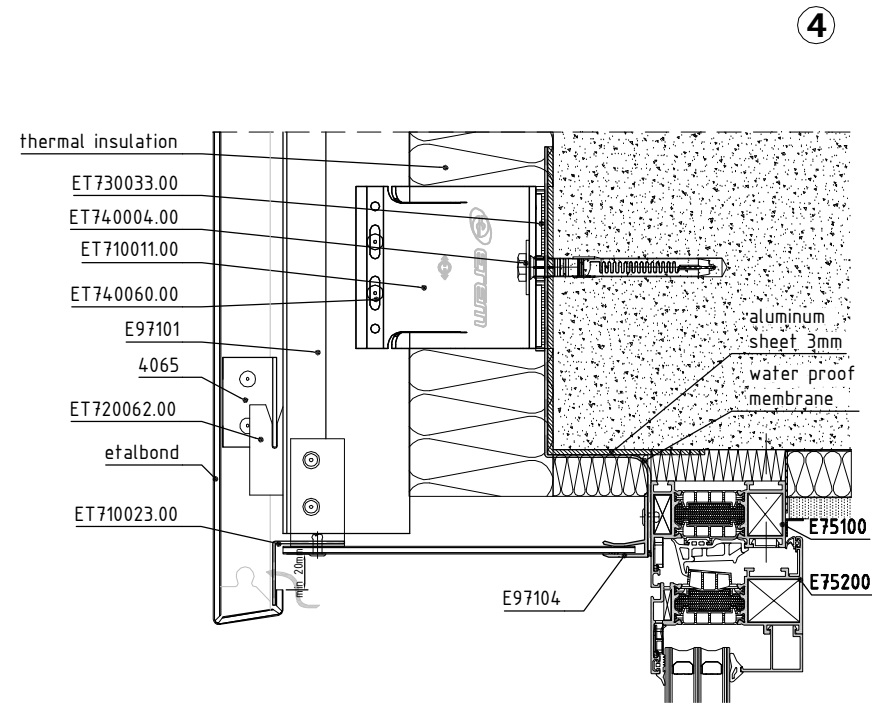
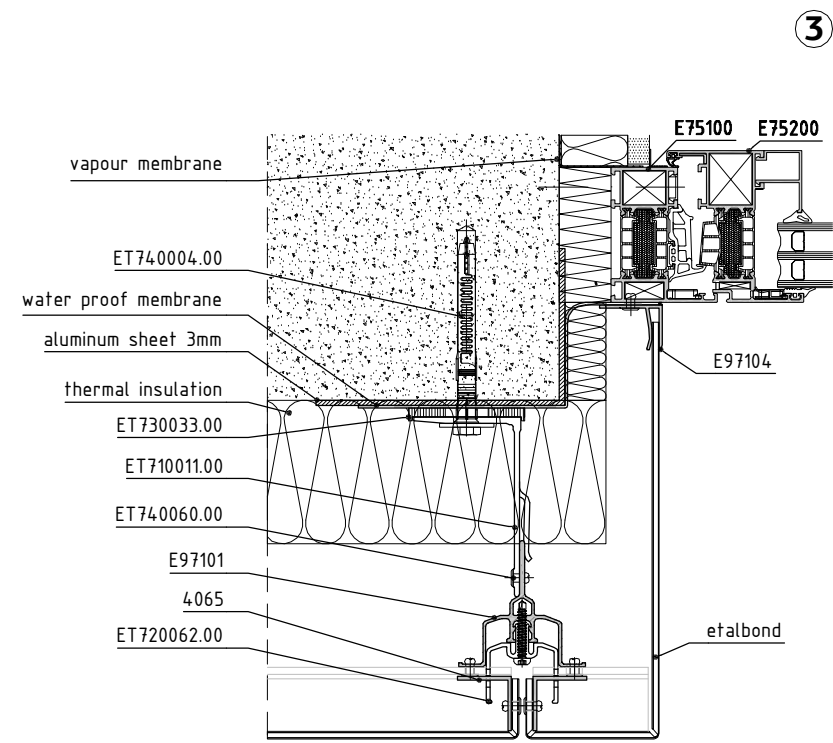

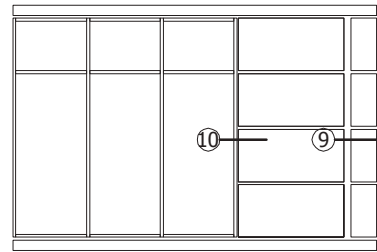

9

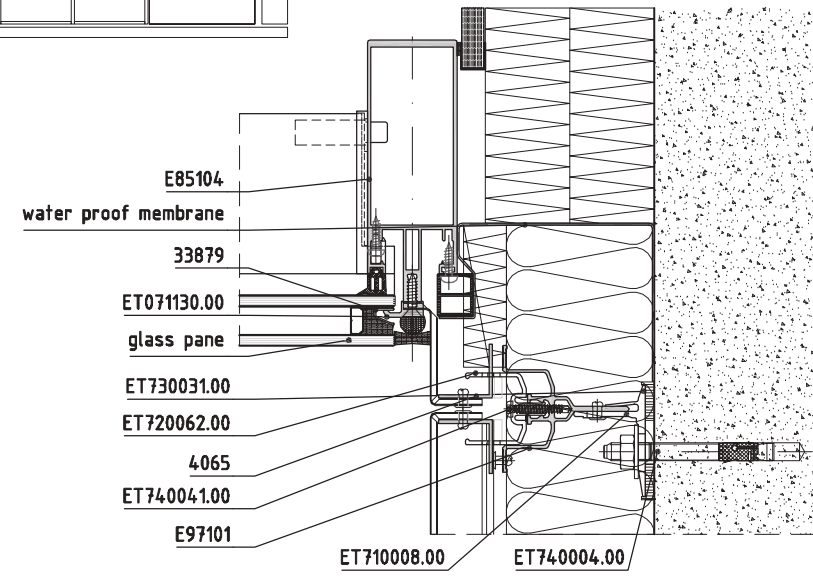

10

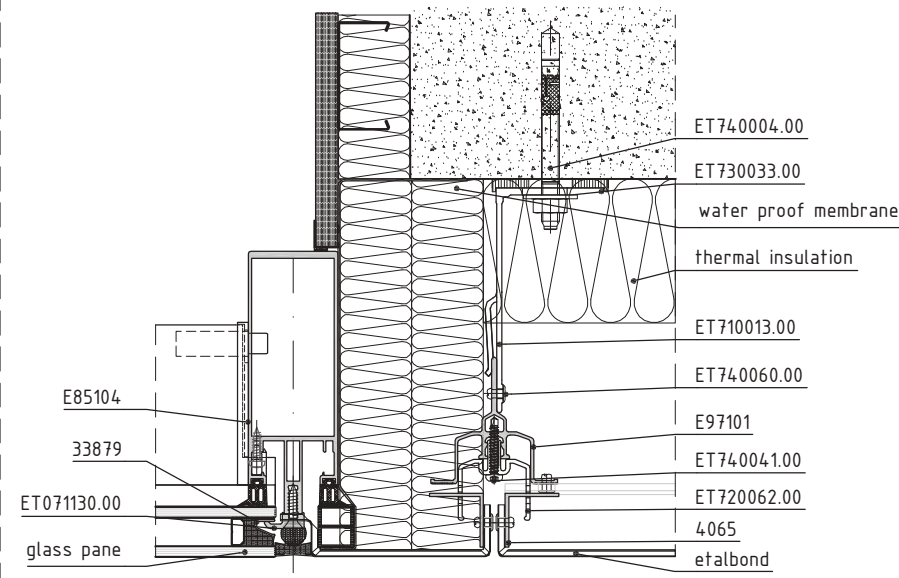

10

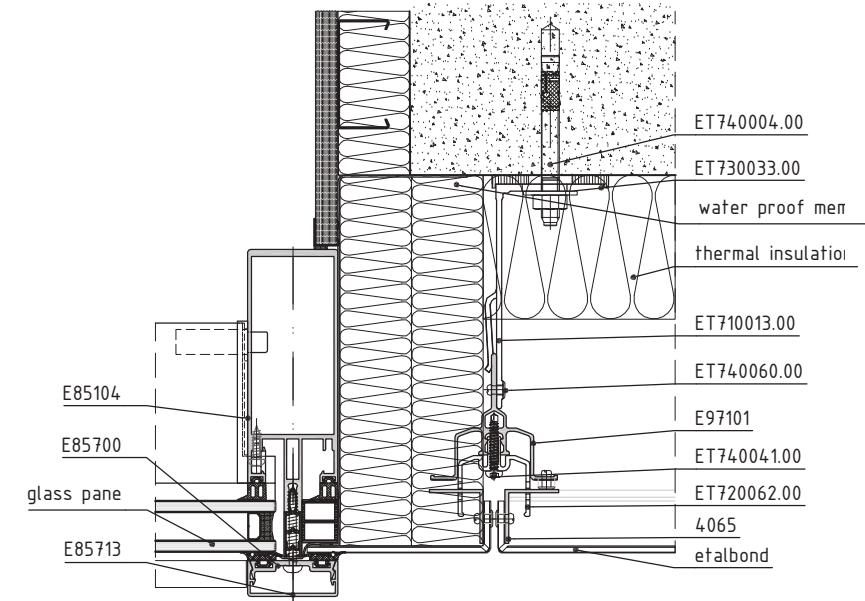



BRAVO H

BRAVO H SYSTEM IS DESIGNED FOR INSTALLATION OF COMPOSITE MATERIALS AND METAL SHEETS, BY USING THE EASIEST AND SIMPLE CLADDING PRINCIPLE (TONGUE AND GROOVE). THE SYSTEM IS AN OPTIMAL SOLUTION FOR LARGE AND FLAT FAÇADES.

MAIN ADVANTAGES:

- fast and secure installation
- widescreen raster on the façades can be manufactured
- special accessories to avoid the clatter noise between the horizontal profiles
- possibility for large span of the panels depending on the applied loads
- variable horizontal and vertical gap (min 4 – max 21 mm)

CLADDING MATERIALS: Aluminium Composite Material, Metal sheet products.

code	profile	weight length moment of inertia	code	profile	weight length moment of inertia
E 97004 main profile grooved		646 g/m L=6.01 m Ix=8.67 cm ⁴ Iy=7.26 cm ⁴	4218 main profile		640 g/m L=6.01 m Ix=8.56 cm ⁴ Iy=8.56 cm ⁴
E 97003 main profile		603 g/m L=6.01 m Ix=7.78 cm ⁴ Iy=3.25 cm ⁴	4065 supporting profile		314 g/m L=6.01 m Ix=1.02 cm ⁴ Iy=1.02 cm ⁴
E 97217 main profile grooved		875 g/m L=6.01 m Ix=9.51 cm ⁴ Iy=20.03 cm ⁴	E 97106 horizontal profile		568 g/m L=6.01 m Ix=1.988 cm ⁴ Iy=4.188 cm ⁴
E 97218 main profile grooved		567 g/m L=6.01 m Ix=2.96 cm ⁴ Iy=7.92 cm ⁴	E 97107 horizontal profile		365 g/m L=6.01 m Ix=1.834 cm ⁴ Iy=2.317 cm ⁴
4049 main profile		596 g/m L=6.01 m Ix=27.70 cm ⁴ Iy=19.39 cm ⁴	ET130439.00 silicone gasket ET730040.00 silicone gasket pack		1000mm length 500 pcs
			note: 50mm gasket - 2 gaskets per each 1m length		

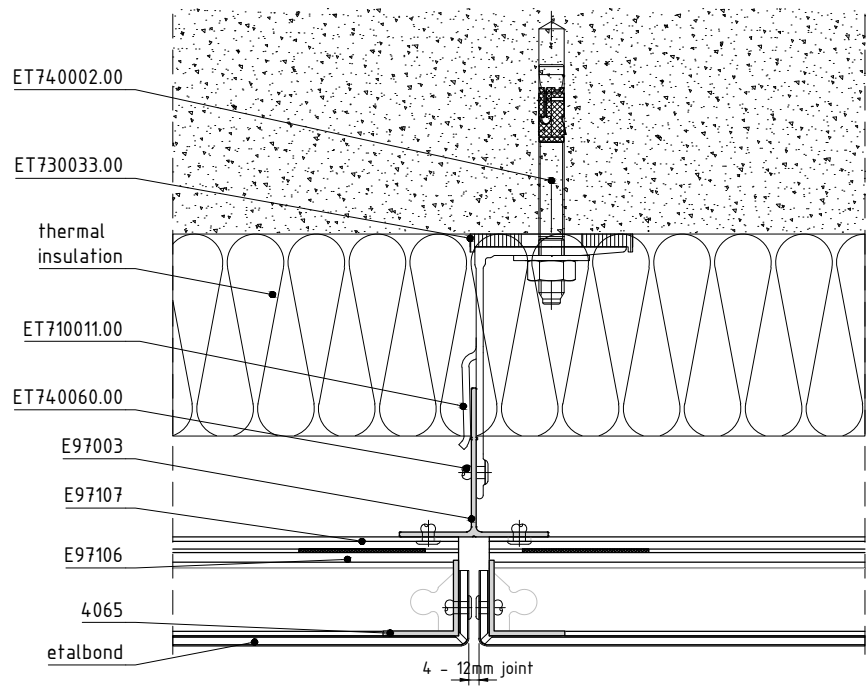
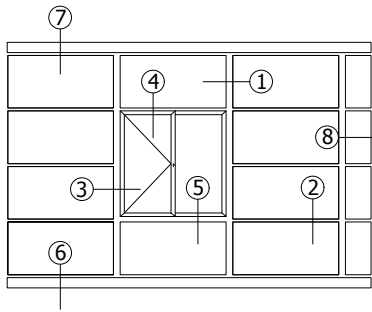

①

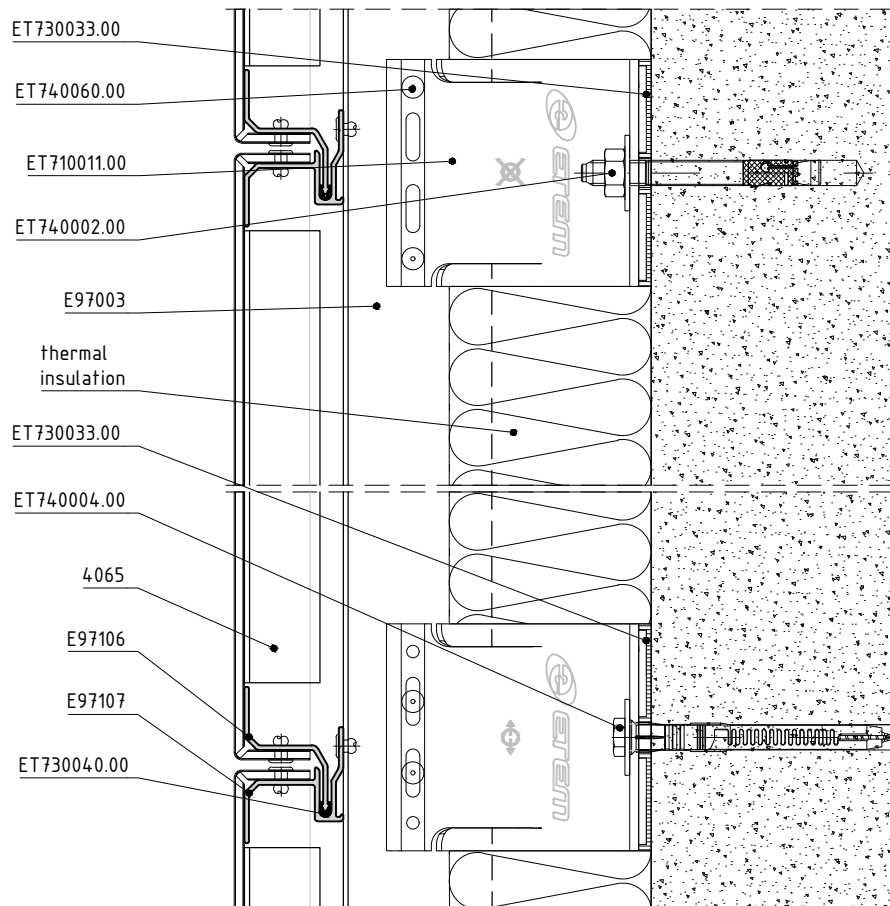

②

③

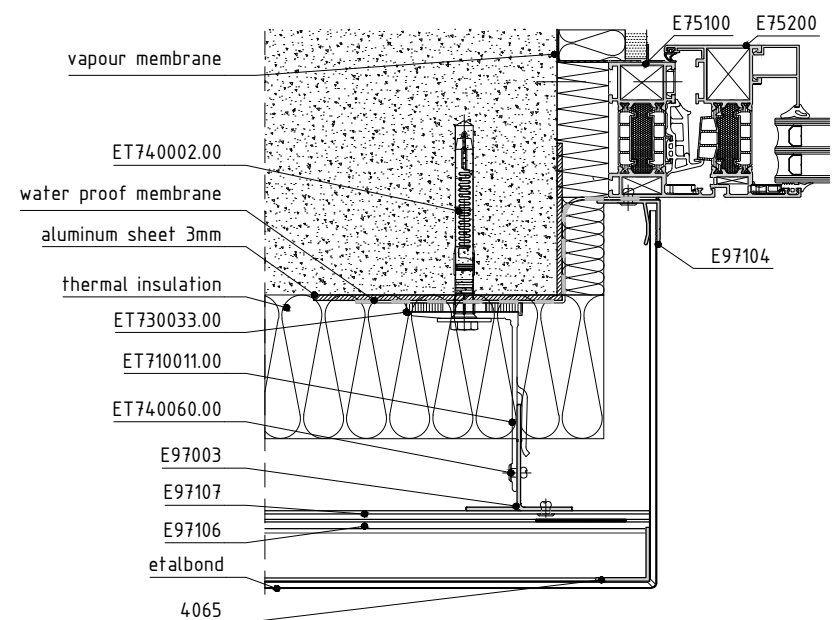

④

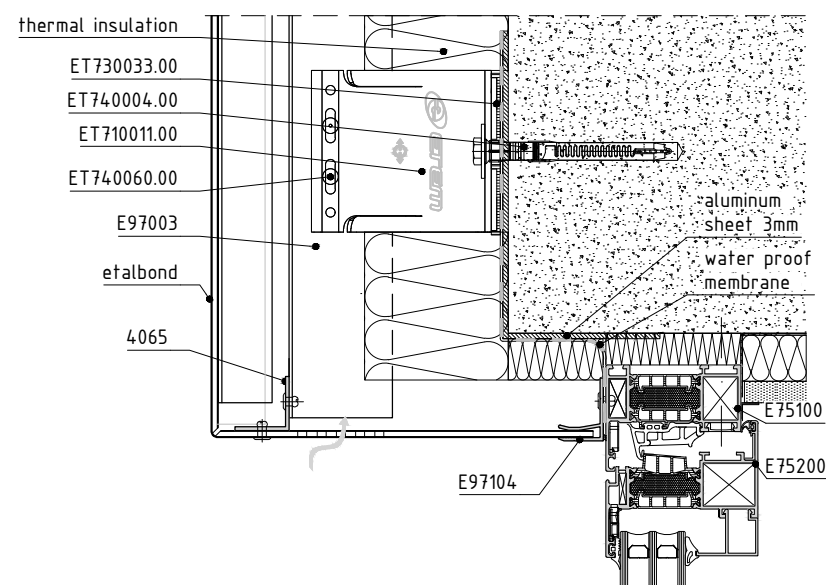

⑤

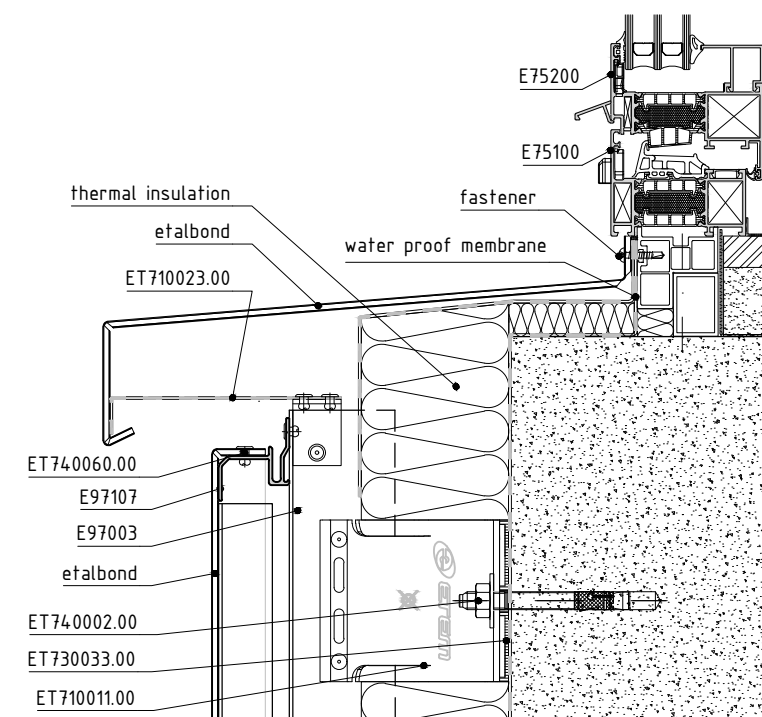

⑥

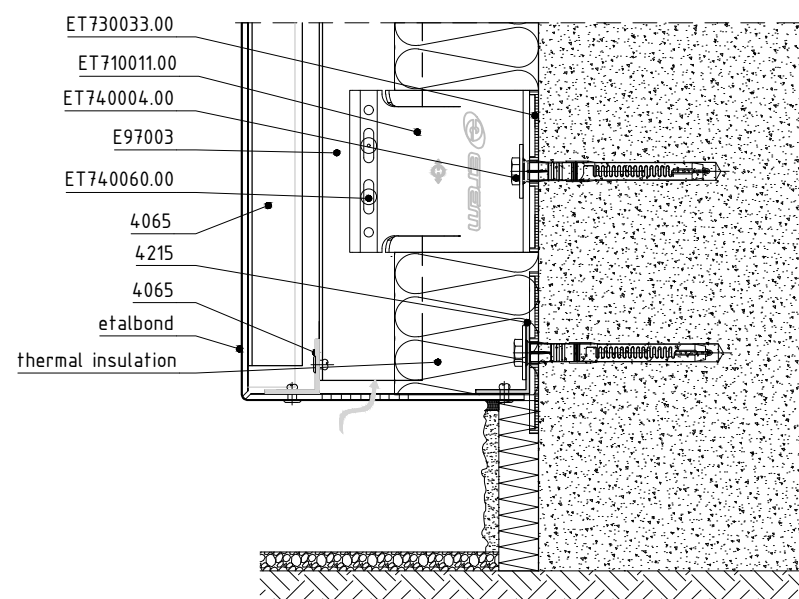

⑦

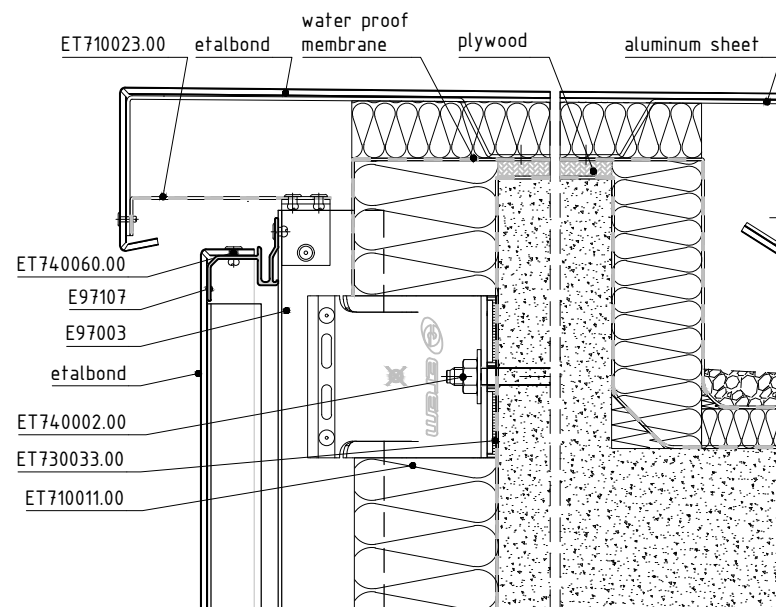

⑧

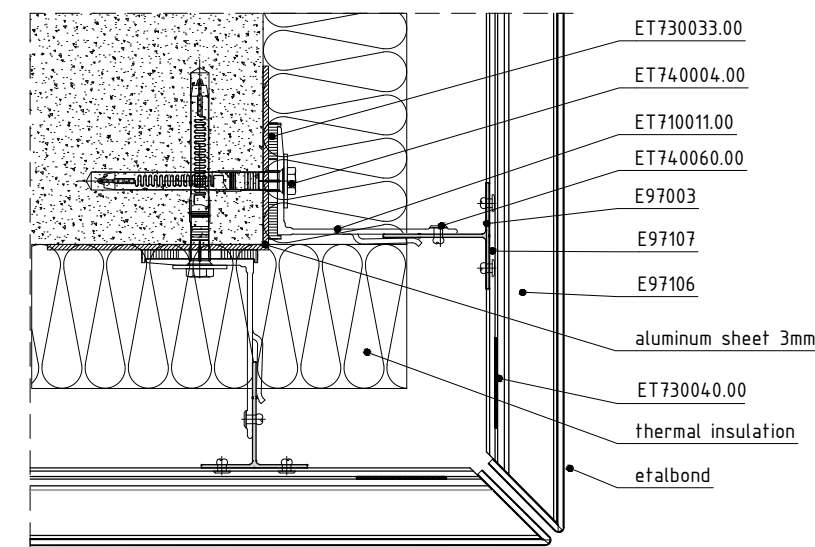

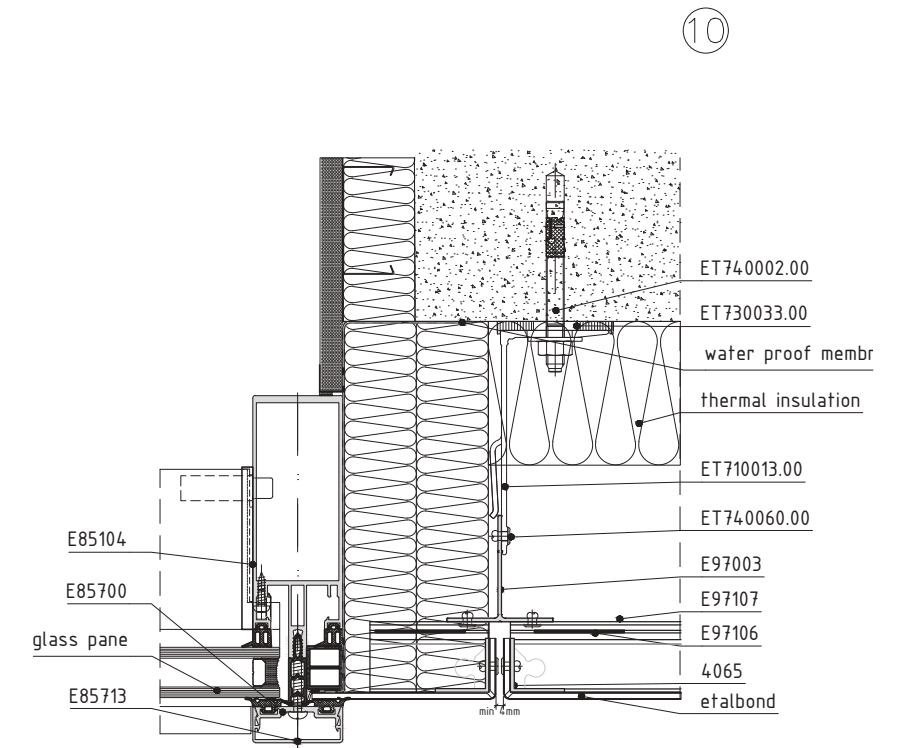
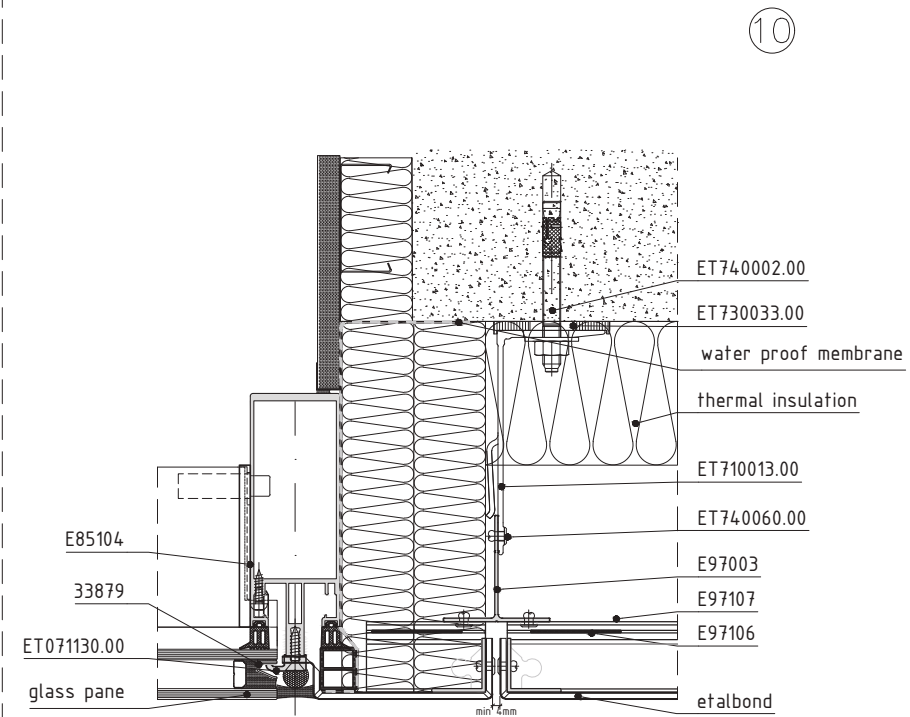
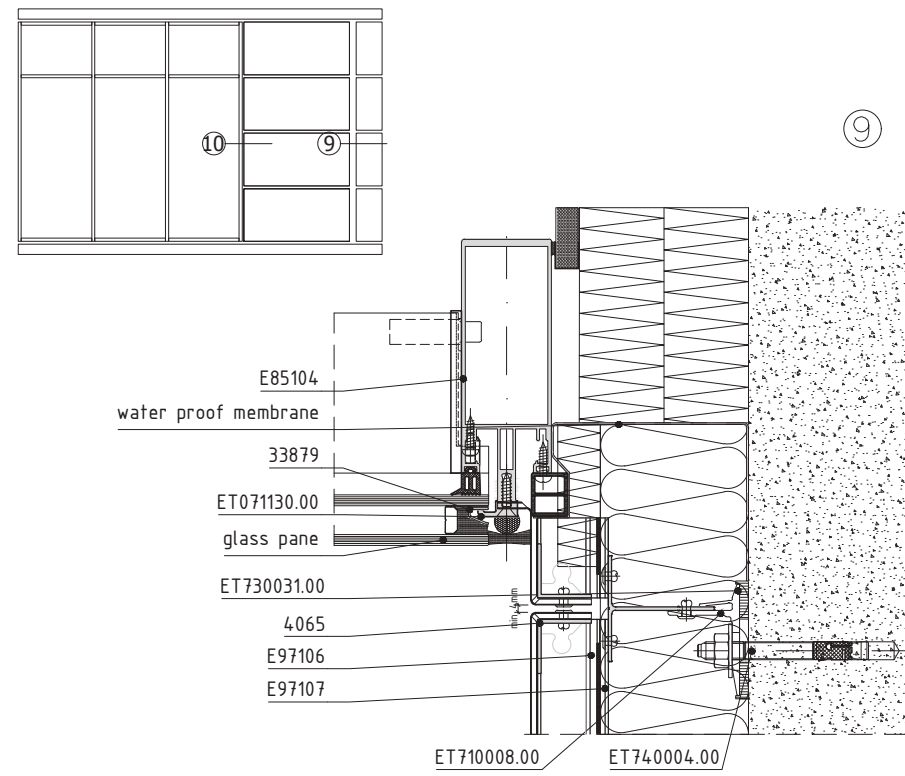



VARIO

VARIO Lamella / VARIO GH / VARIO Glue / VARIO Fixings / VARIO Clips

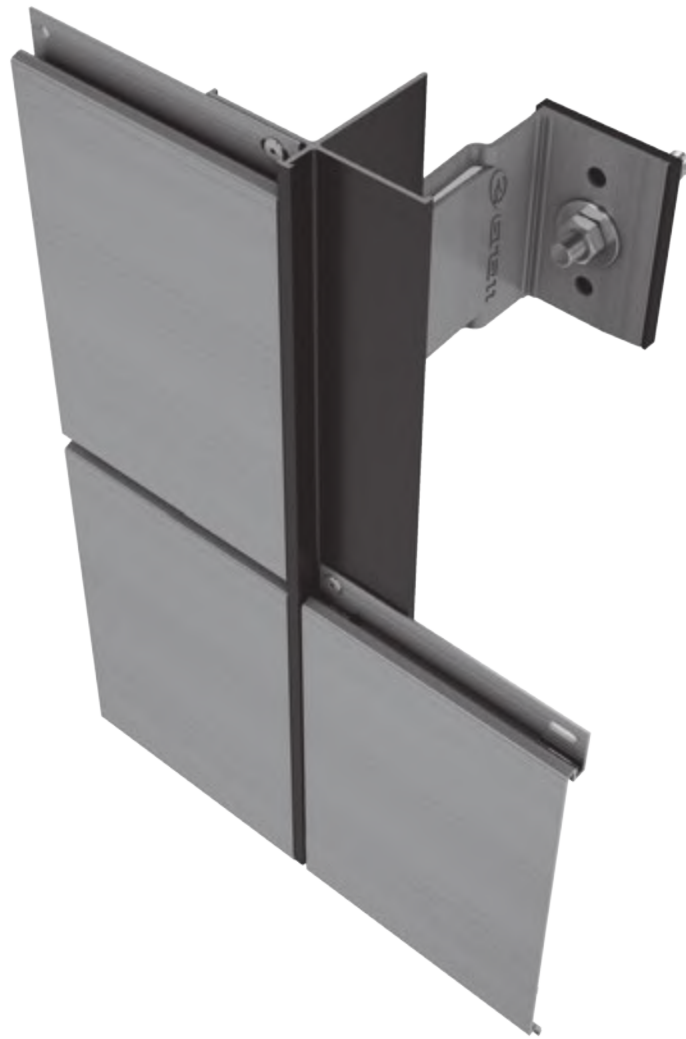



VARIO Lamella

SYSTEM FOR VENTILATED CURTAIN WALL CONSISTING ENTIRELY OF EXTRUDED ALUMINIUM ELEMENTS. VARIO LAMELLA DIFFERS FROM THE EXISTING SOLUTIONS WITH THE UNIQUE CLADDING MATERIAL- ETEM ALUMINIUM LAMELLA. THE PRODUCT ENSURES ACCURATE FIXED 8 MM VERTICAL GAP BY SPECIALLY SELECTED MAIN VERTICAL PROFILE AND 8 MM HORIZONTAL NEGATIVE GAP, DEFINED BY THE LAMELLAS.

MAIN ADVANTAGES:

- quick and easy installation due to only one main façade material without additional accessories
- custom made sizes of lamellas
- wide range of finishes and colors
- low weight of just 6 kg/m², facilitating the transportation, loading, unloading and installation
- allows the use of very long lamella, in the case of severe loading and provides excellent performance in terms of statics

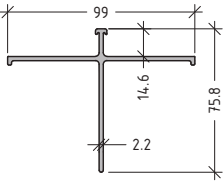
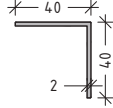
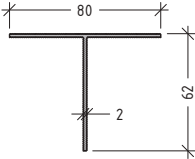
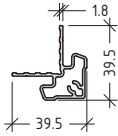
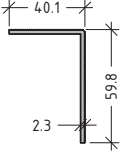
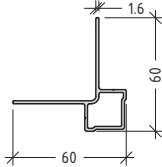
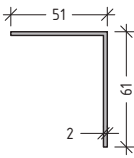
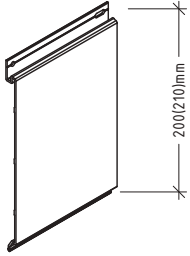
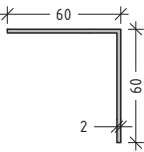
CLADDING MATERIAL: ETEM Aluminium Lamella.

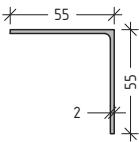
code	profile	weight length moment of inertia	code	profile	weight length moment of inertia
E 97208 main profile		1087 g/m L=6.01 m Ix=13.08 cm ⁴ Iy=19.98 cm ⁴	4131 main profile		423 g/m L=6.01 m Ix=2.47 cm ⁴ Iy=2.47 cm ⁴
E 97004 main profile grooved		646 g/m L=6.01 m Ix=8.67 cm ⁴ Iy=7.26 cm ⁴	E 97229 horizontal corner profile		541 g/m L=6.01 m
E 97218 main profile grooved		567 g/m L=6.01 m Ix=2.96 cm ⁴ Iy=7.92 cm ⁴	E 97230 vertical corner profile		655 g/m L=6.01 m
4049 main profile		596 g/m L=6.01 m Ix=5.50 cm ⁴ Iy=8.52 cm ⁴	E97924 TR* - 200mm lamella E97930 TR* - 210mm lamella		1241 g/m L=6.01 m 1361 g/m L=6.01 m
4218 main profile		640 g/m L=6.01 m Ix=8.56 cm ⁴ Iy=8.56 cm ⁴	ET130439.00 silicone gasket ET730040.00 silicone gasket pack		1000mm length 500 pcs
LP055501 main profile		591 g/m L=6.01 m Ix=6.6 cm ⁴ Iy=6.6 cm ⁴	note: 50mm gasket - 2 gaskets per each 1m length		

note: TR abbreviation stands for additional treatments (pre-drilled slot holes, etc.). All additional treatments must be accompanied by approved drawings.

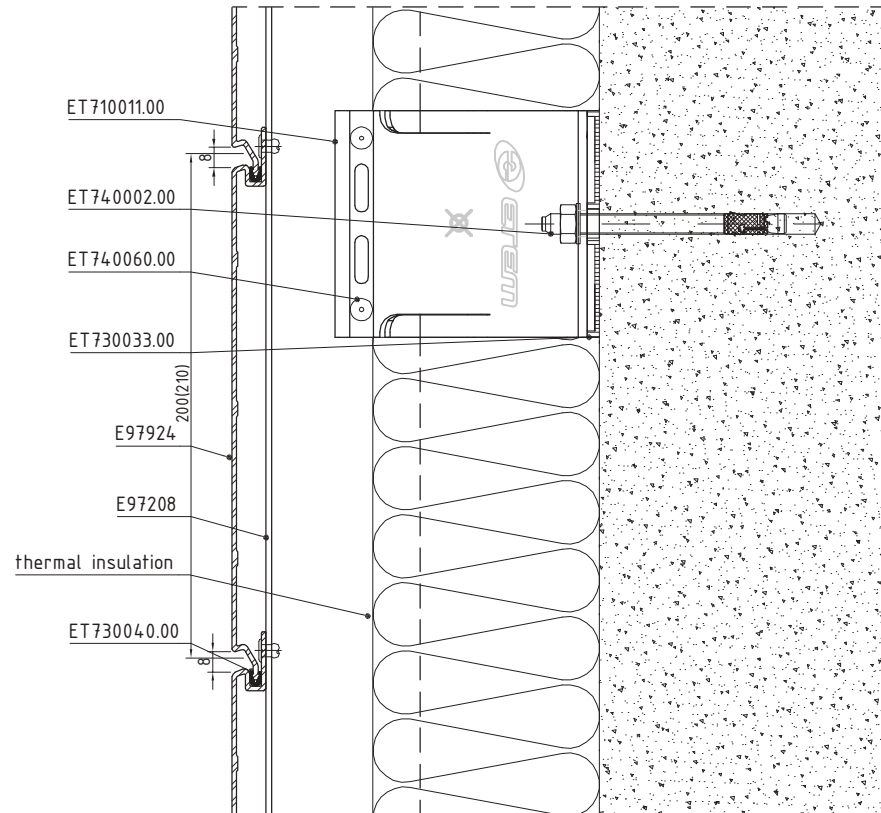
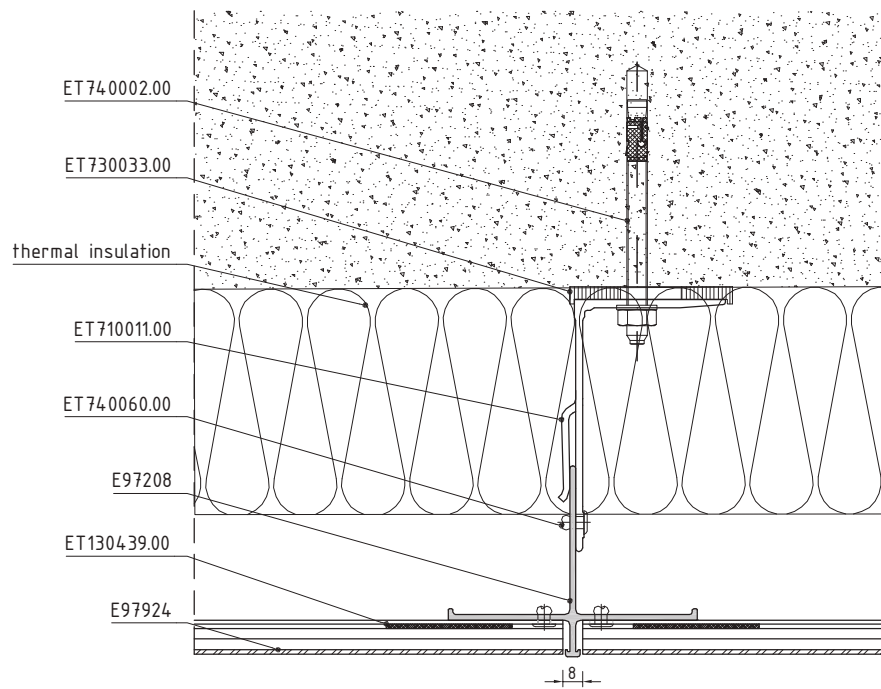
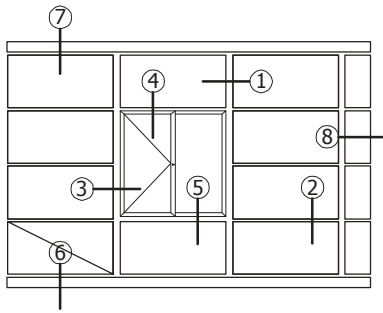

3

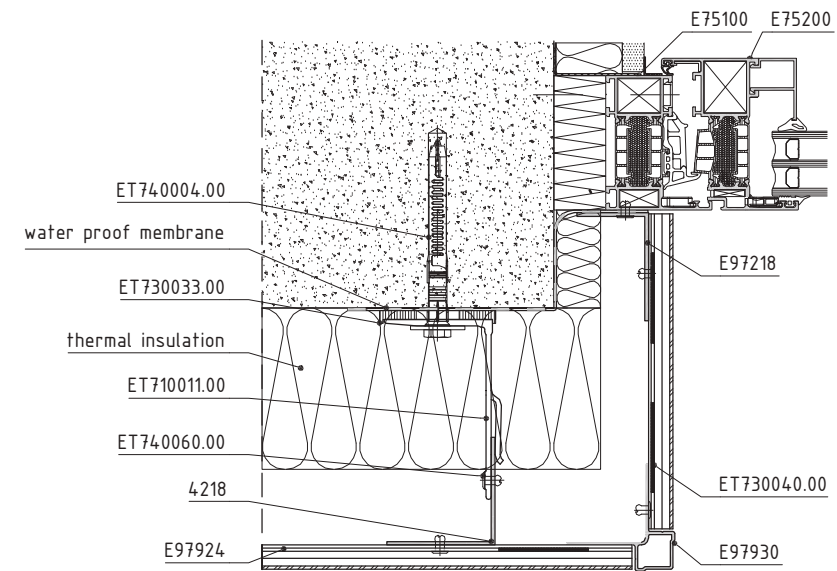

4

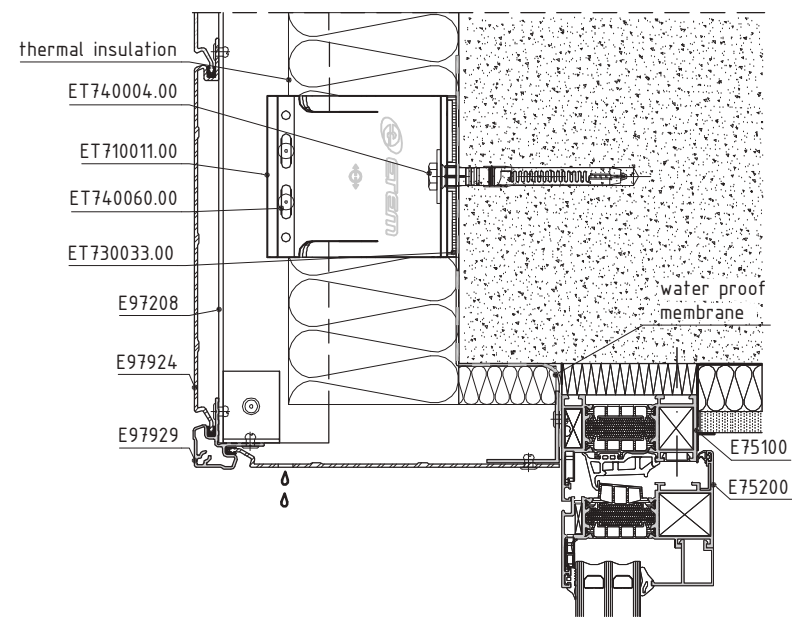

5

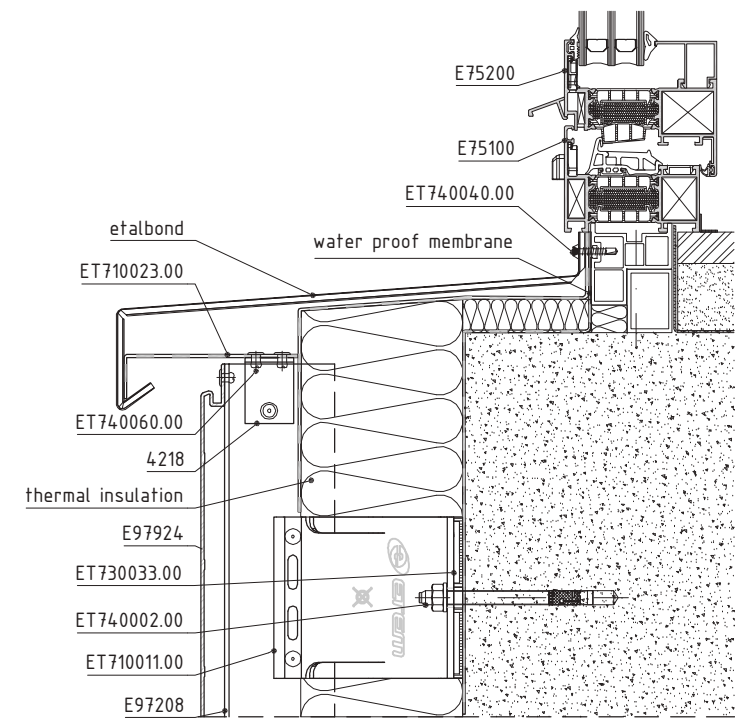

6

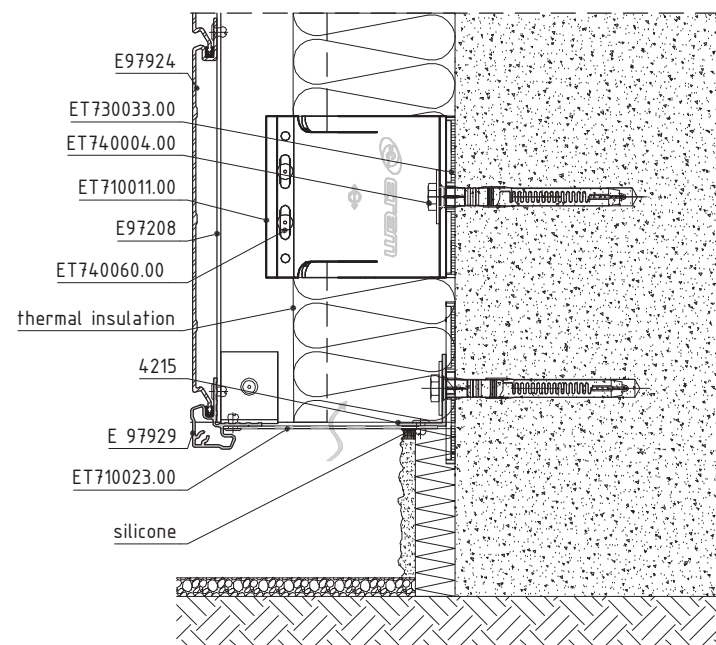

7

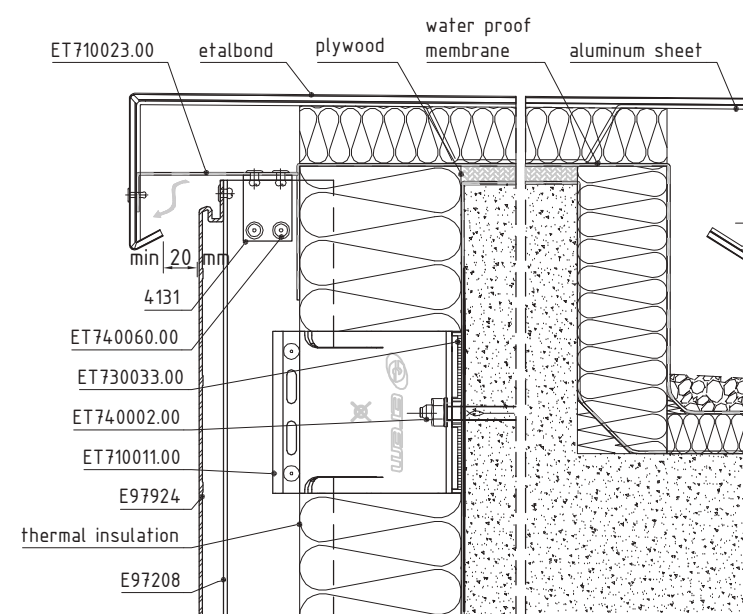

8

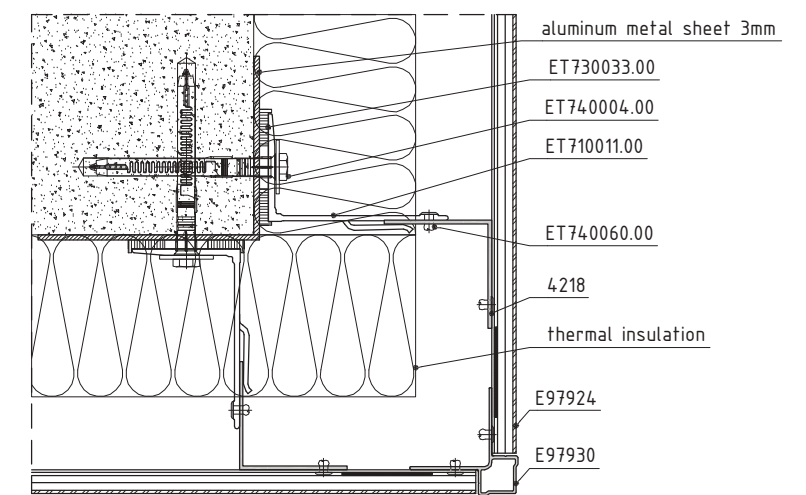



VARIO GH

VARIO GH IS SUPERIOR TO THE EXISTING SOLUTIONS ON THE MARKET INTENDED FOR MATERIAL GLUING. THE ADVANTAGE OF THE SYSTEM IS THE POSSIBILITY TO PERFORM ALL THE PREPARATORY OPERATIONS SUCH AS CUTTING, GLUING, ACCURATE POSITIONING BEFORE GOING ONSITE, WHILE STILL STAYING AT THE CONTROLLED WORKSHOP ENVIRONMENT.

MAIN ADVANTAGES:

- solution for widescreen flat materials
- assembling at a workshop
- preparation for installation of the system does not depend on weather conditions
- increasing of the inertia characteristics of the façade material
- semi- concealed suspension
- ensure mechanical reinforcement of the material
- provides a rigid support (guarantee symmetrical joints)
- higher performance for assembly work

Installation method:

- gluing and hanging

CLADDING MATERIALS: Ceramic Tiles, Glass, High Pressure Laminates (HPL), Fibre Cement, Stone, Technical Stone, Glass Fiber Reinforced Concrete GFRC, GREP, Light Transmitting Concrete.

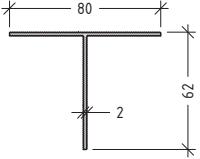
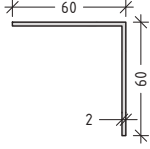
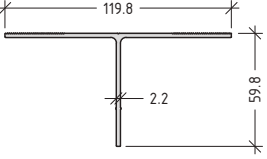
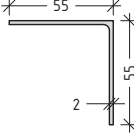
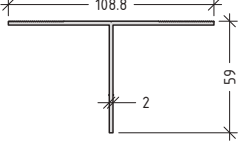
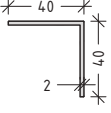
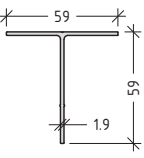
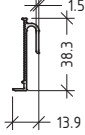
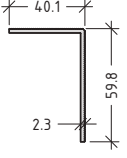
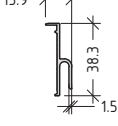
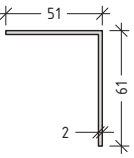
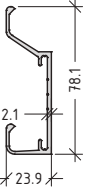
code	profile	weight length moment of inertia	code	profile	weight length moment of inertia
E 97004 main profile grooved		646 g/m L=6.01 m $I_x=8.67 \text{ cm}^4$ $I_y=7.26 \text{ cm}^4$	4218 main profile		640 g/m L=6.01 m $I_x=8.56 \text{ cm}^4$ $I_y=8.56 \text{ cm}^4$
E 97216 main profile grooved		1043 g/m L=6.01 m $I_x=11.10 \text{ cm}^4$ $I_y=29.62 \text{ cm}^4$	LP055501 main profile		591 g/m L=6.01 m $I_x=6.6 \text{ cm}^4$ $I_y=6.6 \text{ cm}^4$
E 97217 main profile grooved		875 g/m L=6.01 m $I_x=9.51 \text{ cm}^4$ $I_y=20.03 \text{ cm}^4$	4131 main profile		423 g/m L=6.01 m $I_x=2.47 \text{ cm}^4$ $I_y=2.47 \text{ cm}^4$
E 97003 main profile		603 g/m L=6.01 m $I_x=7.78 \text{ cm}^4$ $I_y=3.25 \text{ cm}^4$	E 97925 bottom horizontal profile		242 g/m L=6.01 m $I_x=1.23 \text{ cm}^4$ $I_y=0.08 \text{ cm}^4$
E 97218 main profile grooved		567 g/m L=6.01 m $I_x=2.96 \text{ cm}^4$ $I_y=7.92 \text{ cm}^4$	E 97926 top horizontal profile		240 g/m L=6.01 m $I_x=1.04 \text{ cm}^4$ $I_y=0.08 \text{ cm}^4$
4049 main profile		596 g/m L=6.01 m $I_x=5.50 \text{ cm}^4$ $I_y=8.52 \text{ cm}^4$	E 97927 hanging profile		742 g/m L=6.01 m $I_x=16.50 \text{ cm}^4$ $I_y=2.14 \text{ cm}^4$

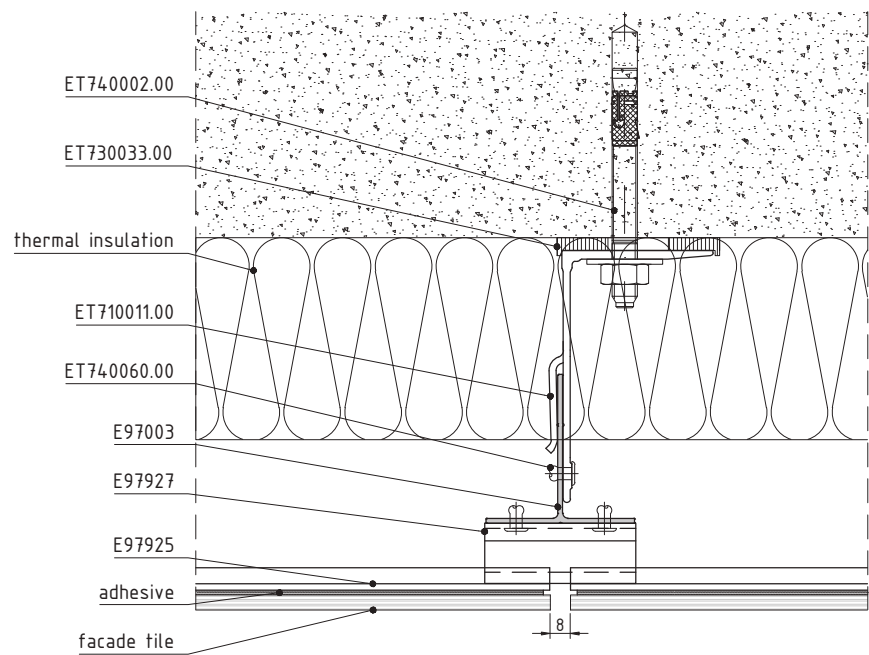
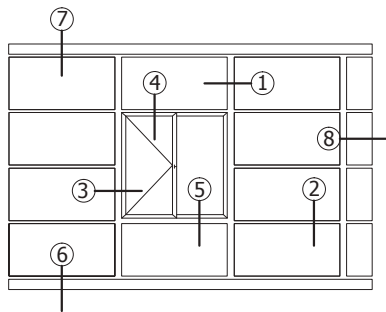

1

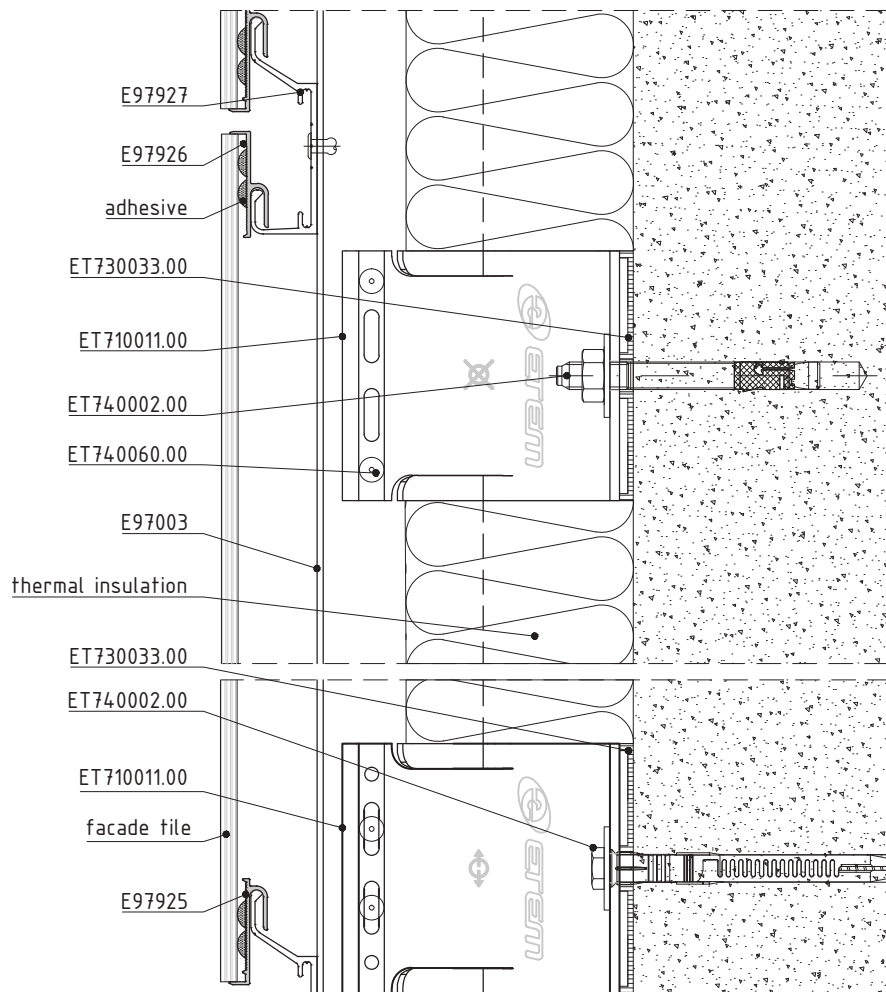

2

3

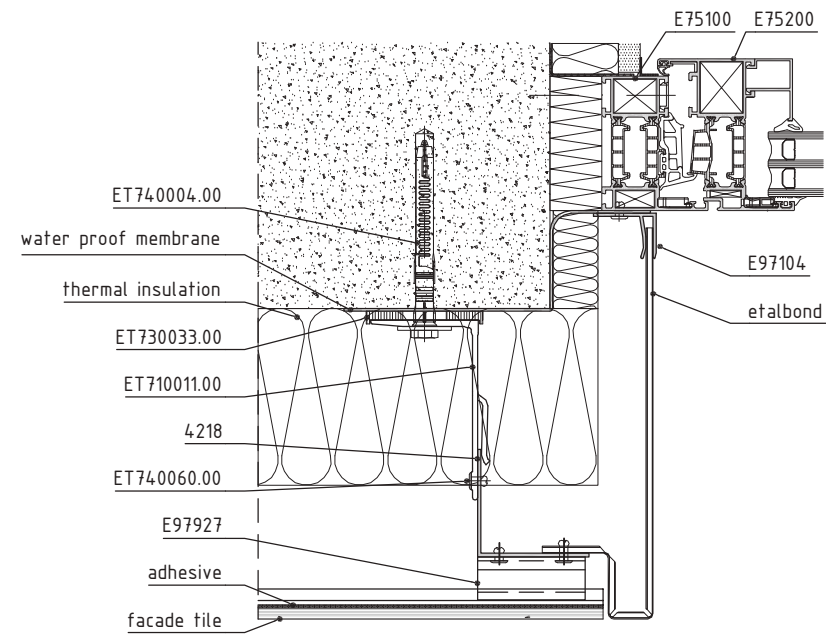

4

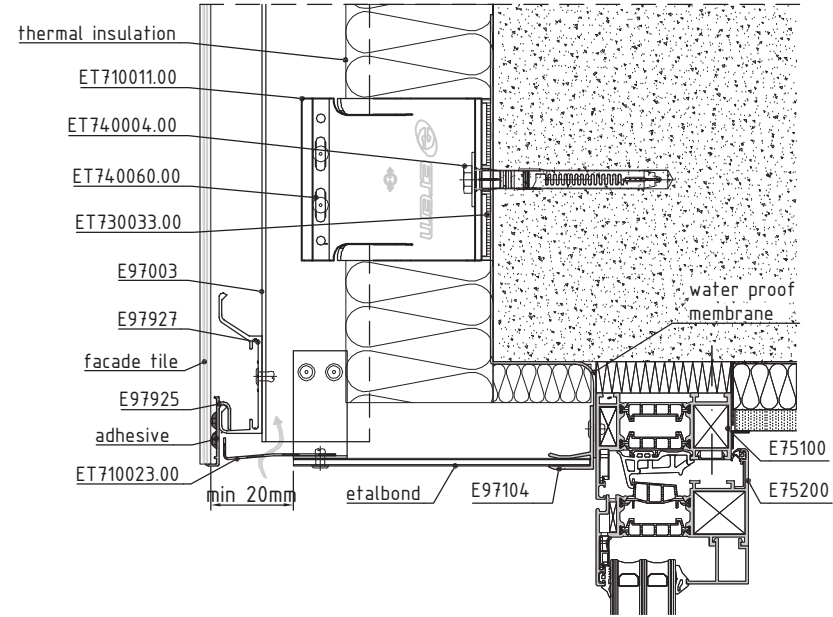

5

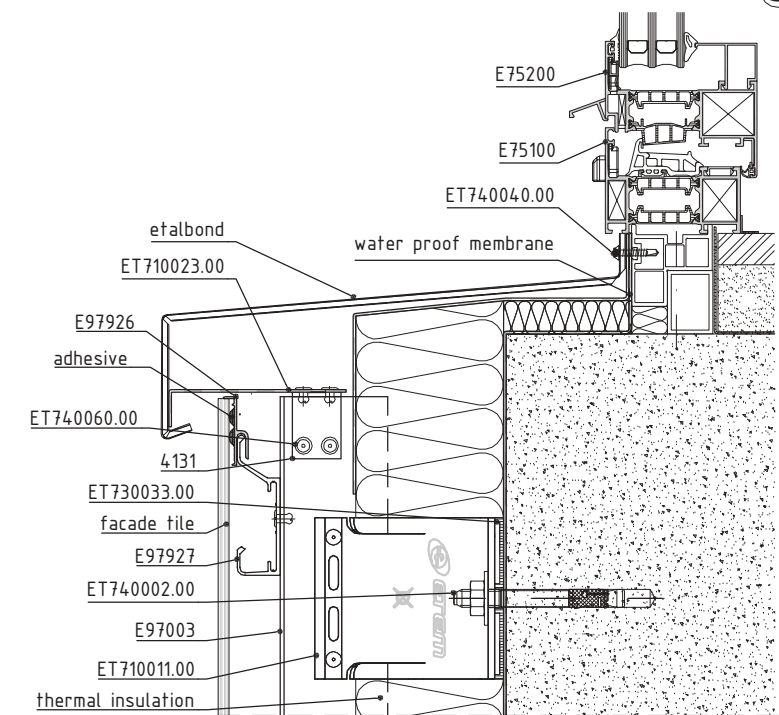

6

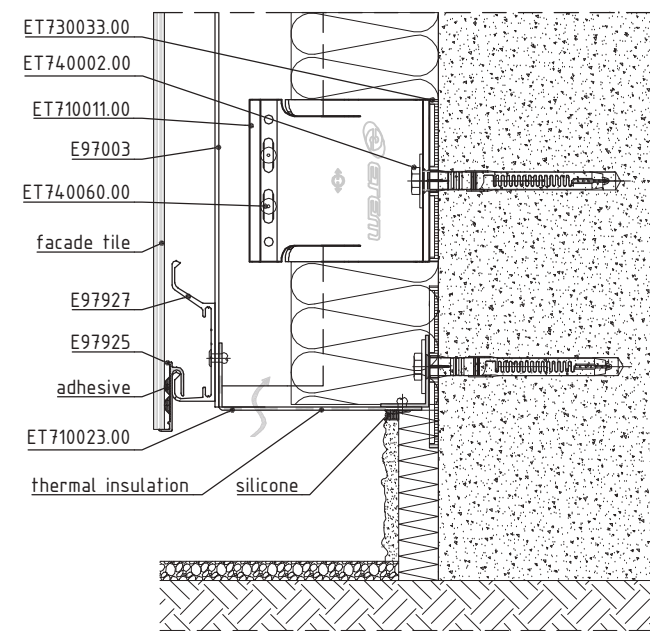

7

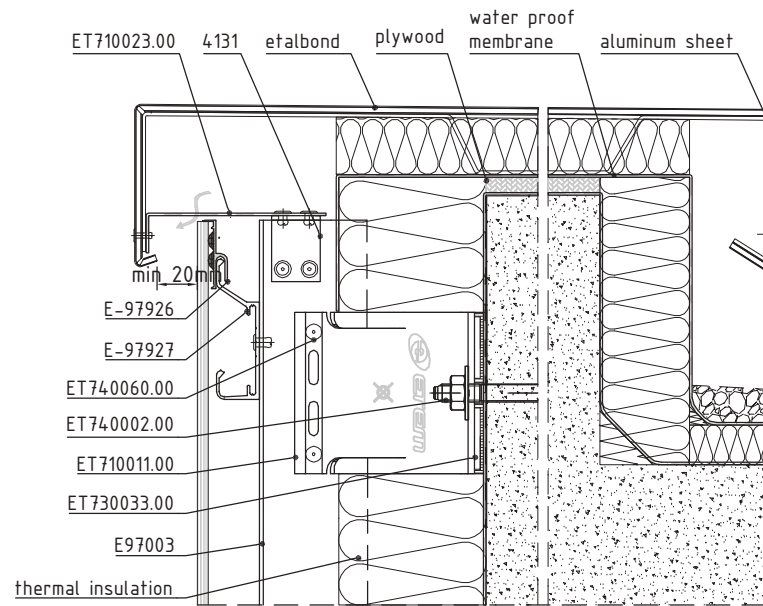

8

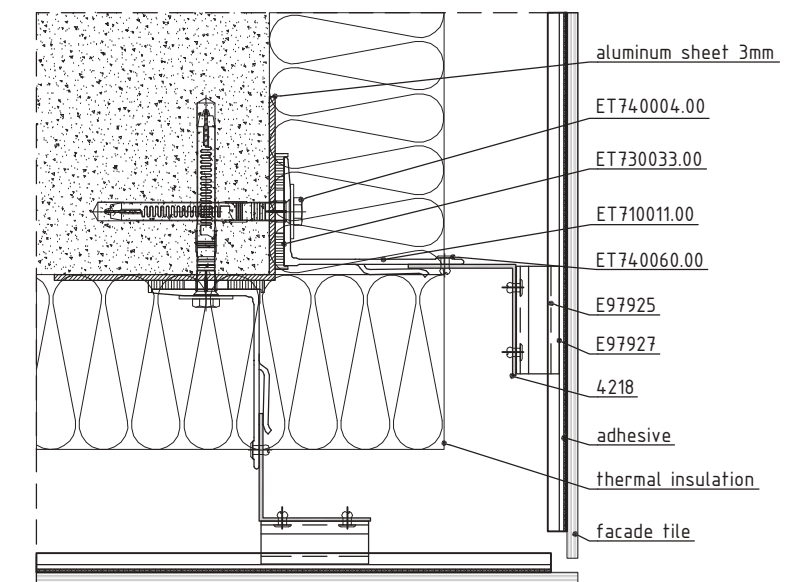



VARIO Glue

THE SYSTEM IS INTENDED FOR GLUING SHEET MATERIALS ON THE FAÇADE CONSTRUCTION, REPLACING THE USE OF MECHANICAL ELEMENTS (RIVETS, ETC.). THE DESIGN OFFERS A WIDE RANGE OF PROFILES AND BRACKETS FOR INSTALLATION OF CERAMIC, METAL, COMPOSITES, GLASS AND OTHER FAÇADE CLADDING.

MAIN ADVANTAGES:

- resistance to all temperatures
- strength of the adhesive bond
- high resistance to external environment conditions
- excellent performance when subjected to high wind pressure
- adhesive lasting elasticity, guaranteed by the manufacturer

CLADDING MATERIALS: Glass, High Pressure Laminates (HPL), Fibre Cement, Composite Mineral Material, Glass Fiber Reinforced Concrete GFRC, GREP

code	profile	weight length moment of inertia	code	profile	weight length moment of inertia
E 97004 main profile grooved		646 g/m L=6.01 m Ix=8.67 cm ⁴ Iy=7.26 cm ⁴	4049 main profile		596 g/m L=6.01 m Ix=5.50 cm ⁴ Iy=8.52 cm ⁴
E 97216 main profile grooved		1043 g/m L=6.01 m Ix=11.10 cm ⁴ Iy=29.62 cm ⁴	4218 main profile		640 g/m L=6.01 m Ix=8.56 cm ⁴ Iy=8.56 cm ⁴
E 97217 main profile grooved		875 g/m L=6.01 m Ix=9.51 cm ⁴ Iy=20.03 cm ⁴	LP055501 main profile		591 g/m L=6.01 m Ix=6.6 cm ⁴ Iy=6.6 cm ⁴
E 97003 main profile		603 g/m L=6.01 m Ix=7.78 cm ⁴ Iy=3.25 cm ⁴	4131 main profile		423 g/m L=6.01 m Ix=2.47 cm ⁴ Iy=2.47 cm ⁴
E 97218 main profile grooved		567 g/m L=6.01 m Ix=2.96 cm ⁴ Iy=7.92 cm ⁴			

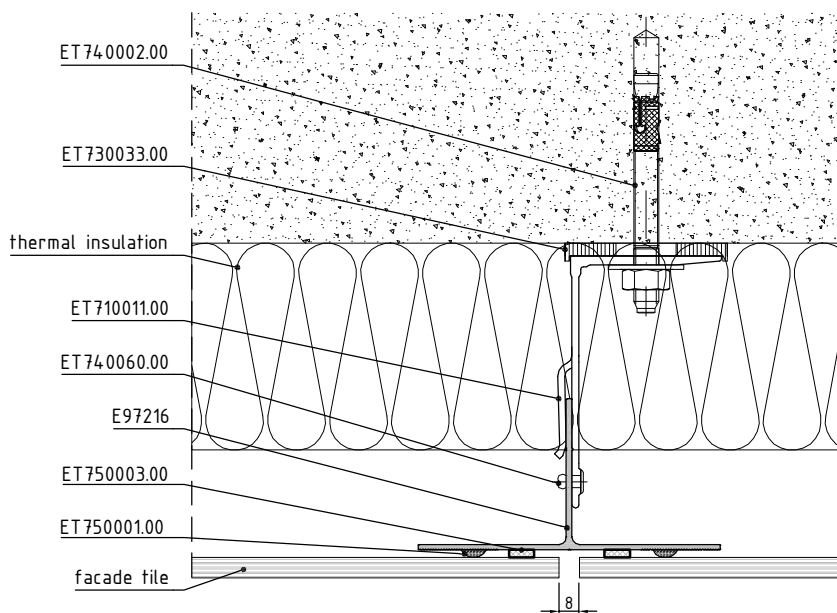
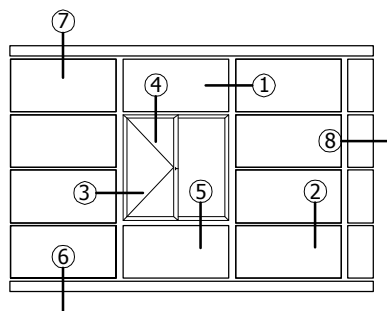

1

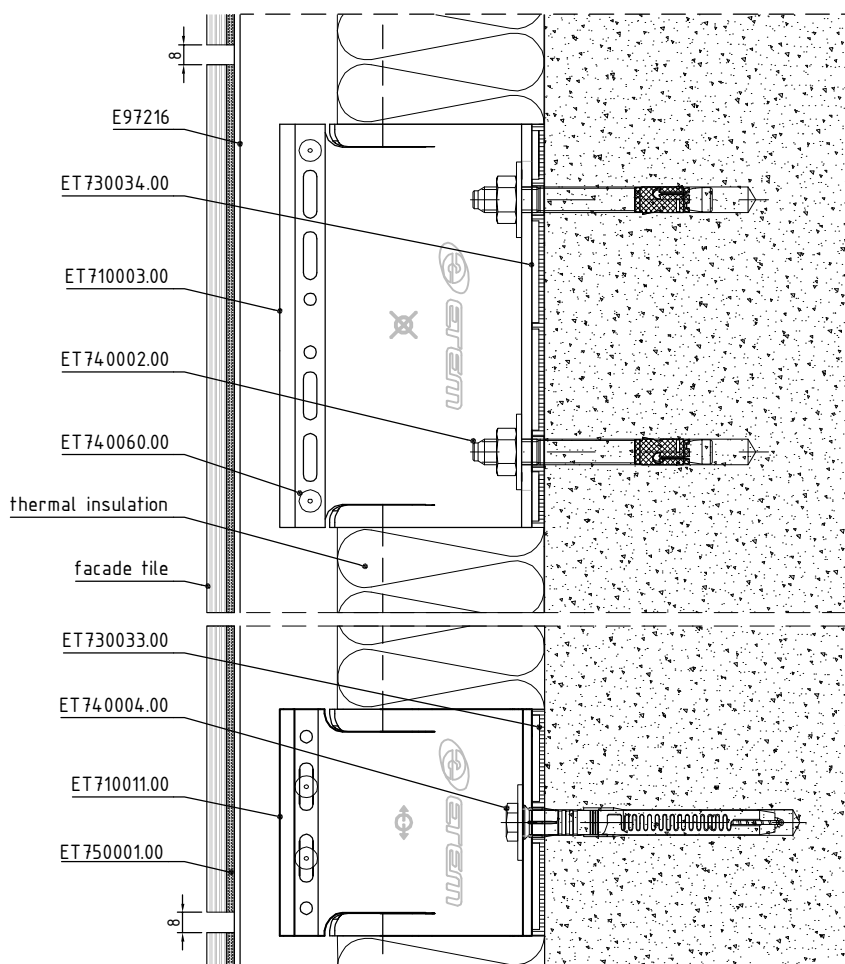

2

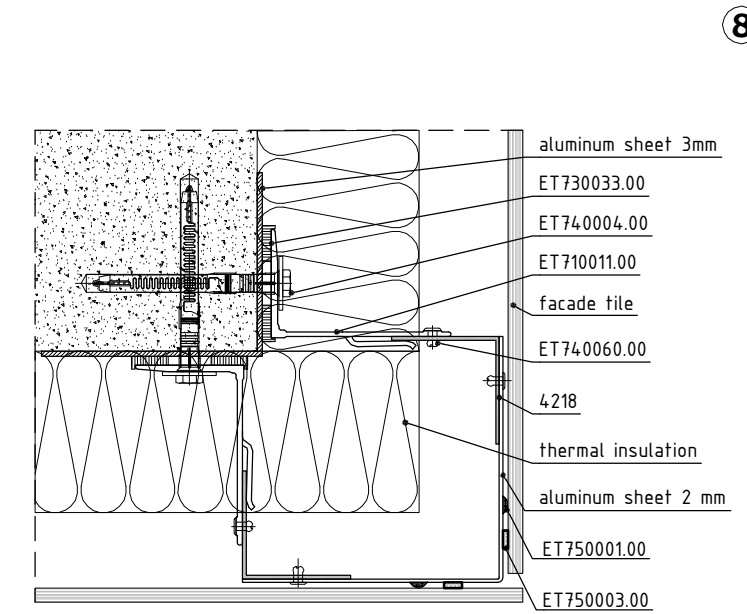
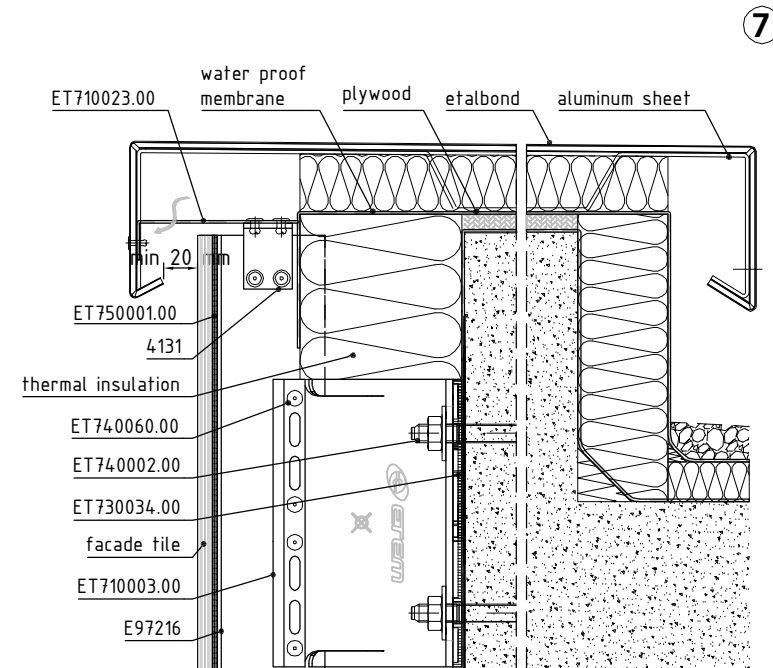
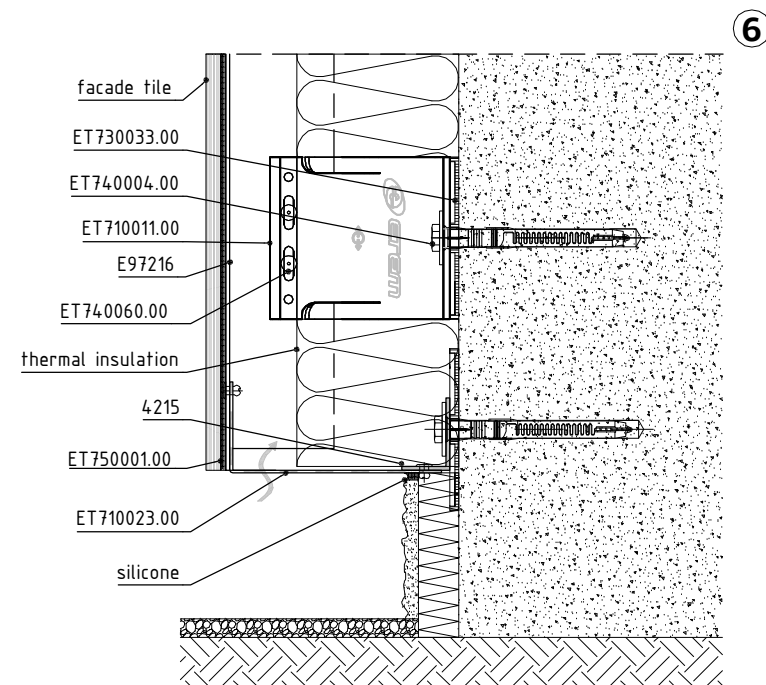
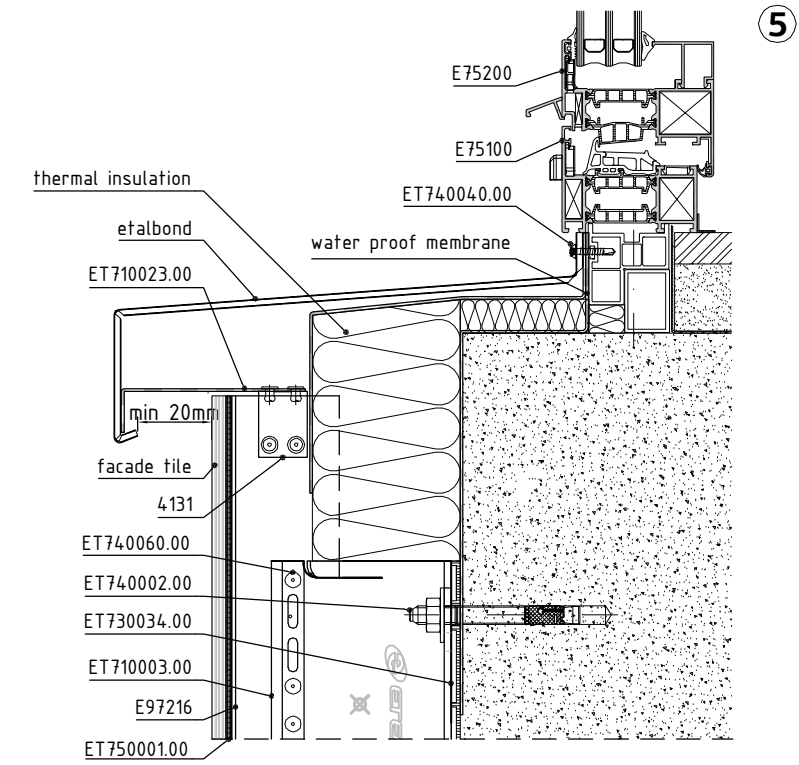
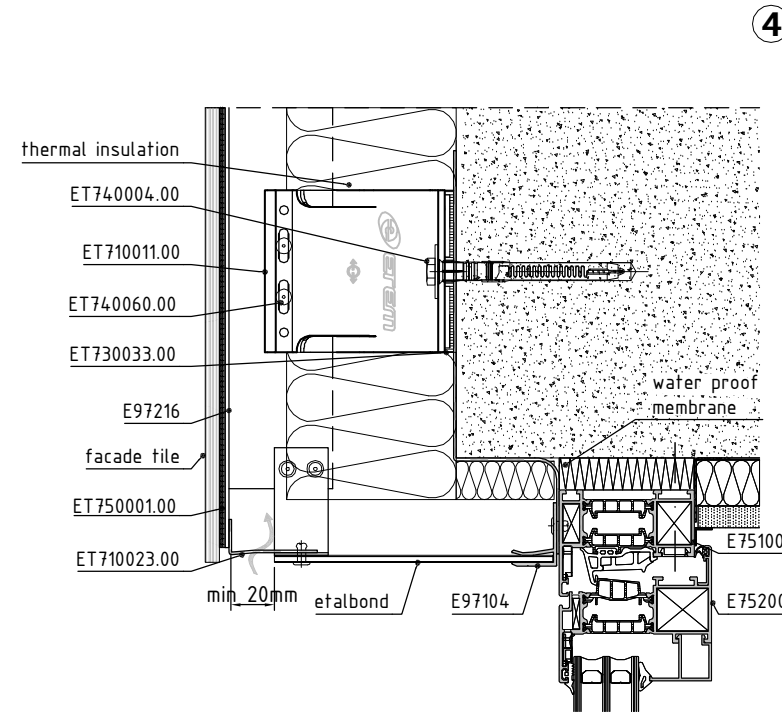
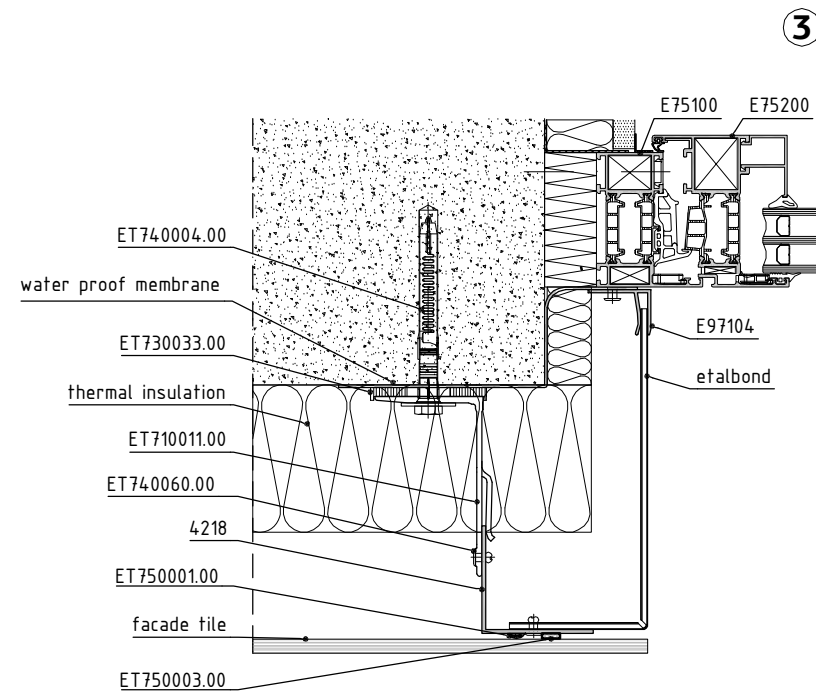



VARIO Fixings

THE SYSTEM IS SUITABLE FOR VISIBLE MOUNTING OF THIN AND SMOOTH FAÇADE MATERIALS, BY USING RIVETS/SCREWS.

MAIN ADVANTAGES:

- quick installation of façade material with different sizes
- possibility to paint the visible fastening elements in a wide range of colours to match the façade material
- possible use of cladding materials with a thickness ranging from 4 mm to 12 mm

CLADDING MATERIALS: Cement Board, High Pressure Laminates (HPL), Fibre Cement, Composite Mineral Material, Glass Fiber Reinforced Concrete GFRC, GREP, Light Transmitting Concrete

VARIO Fixings

E97

code	profile	weight length moment of inertia	code	profile	weight length moment of inertia
E 97004 main profile grooved		646 g/m L=6.01 m $I_x=8.67 \text{ cm}^4$ $I_y=7.26 \text{ cm}^4$	4049 main profile		596 g/m L=6.01 m $I_x=5.50 \text{ cm}^4$ $I_y=8.52 \text{ cm}^4$
E 97216 main profile grooved		1043 g/m L=6.01 m $I_x=11.10 \text{ cm}^4$ $I_y=29.62 \text{ cm}^4$	4218 main profile		640 g/m L=6.01 m $I_x=8.56 \text{ cm}^4$ $I_y=8.56 \text{ cm}^4$
E 97217 main profile grooved		875 g/m L=6.01 m $I_x=9.51 \text{ cm}^4$ $I_y=20.03 \text{ cm}^4$	LP05501 main profile		591 g/m L=6.01 m $I_x=6.6 \text{ cm}^4$ $I_y=6.6 \text{ cm}^4$
E 97003 main profile		603 g/m L=6.01 m $I_x=7.78 \text{ cm}^4$ $I_y=3.25 \text{ cm}^4$	4131 main profile		423 g/m L=6.01 m $I_x=2.47 \text{ cm}^4$ $I_y=2.47 \text{ cm}^4$
E 97218 main profile grooved		567 g/m L=6.01 m $I_x=2.96 \text{ cm}^4$ $I_y=7.92 \text{ cm}^4$	etalbond® special fixing profiles		
			143 g/m	186 g/m	
			11782	11975	
			335 g/m	335 g/m	435 g/m
			E 97400	E 97401	E 97402

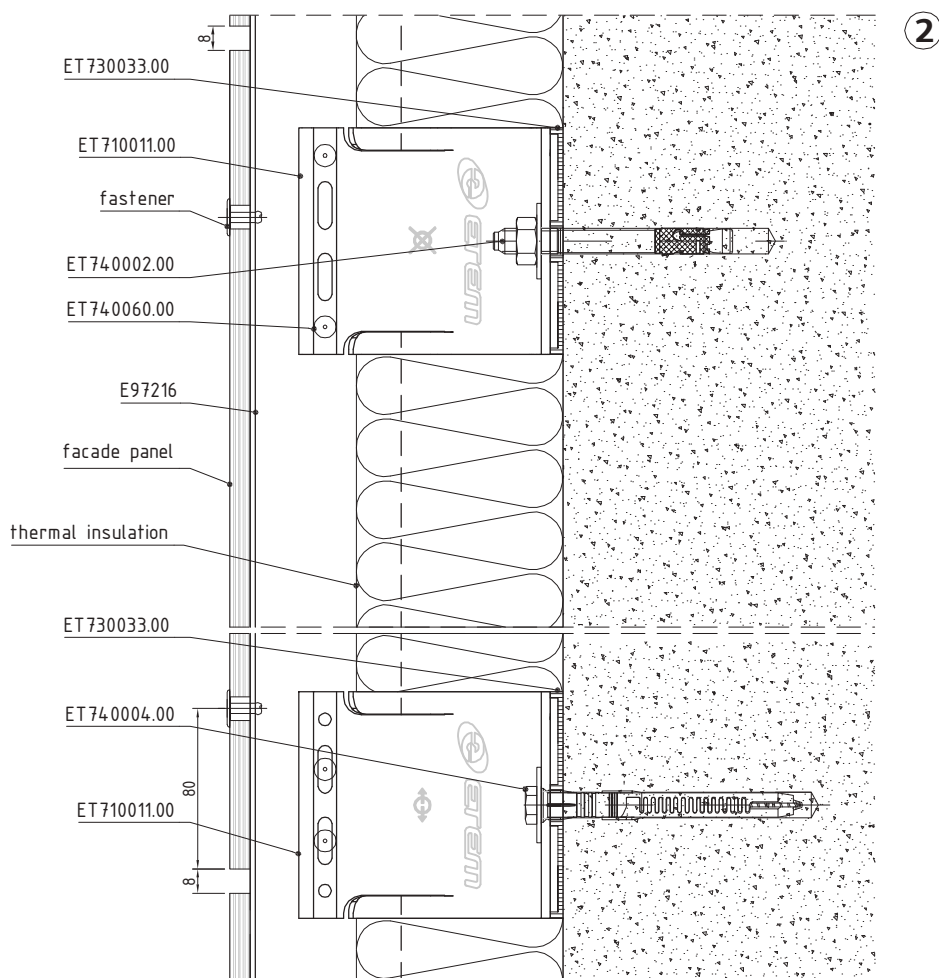
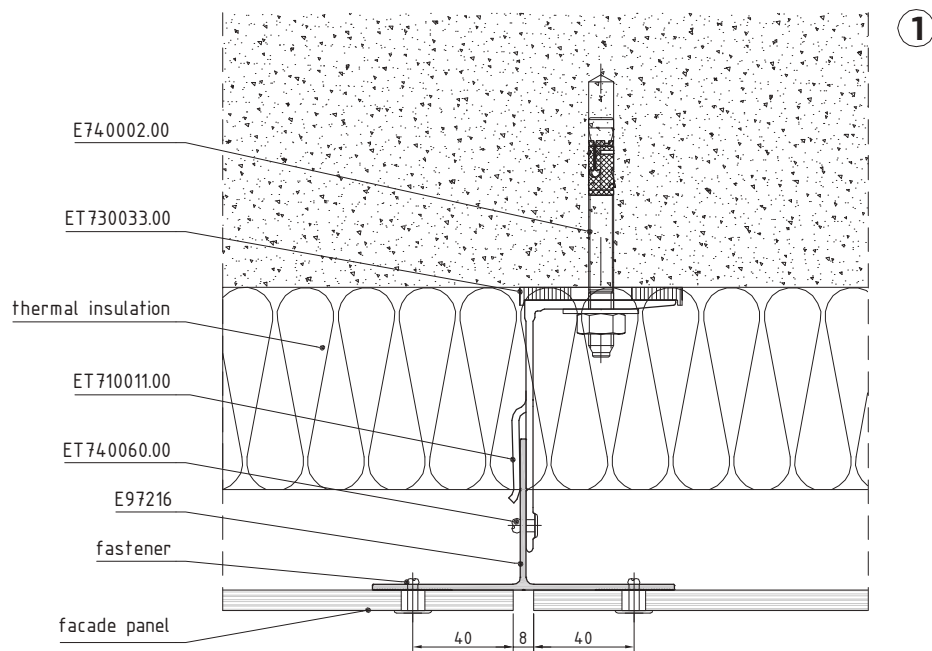
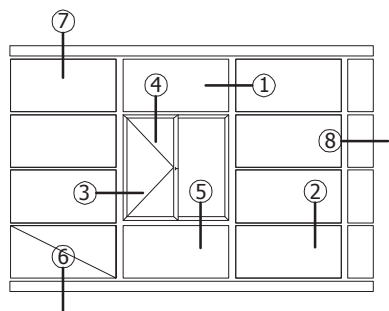

3

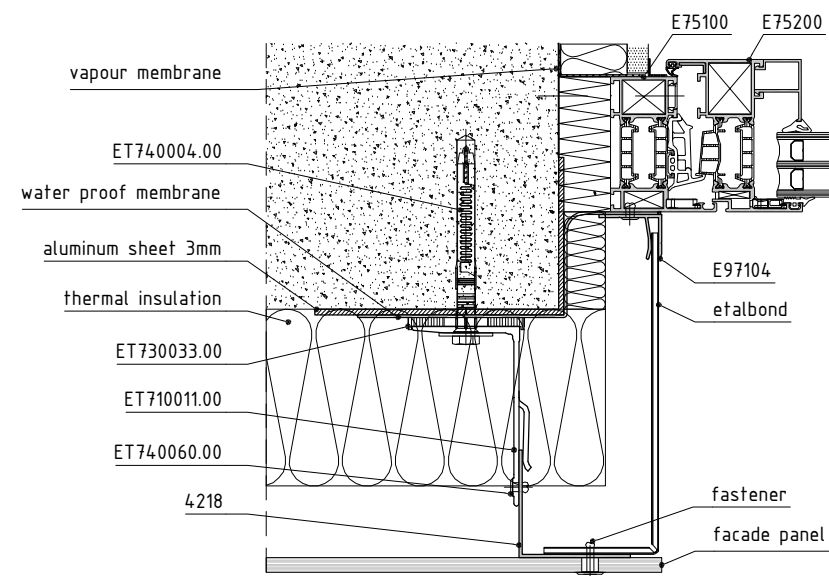

4

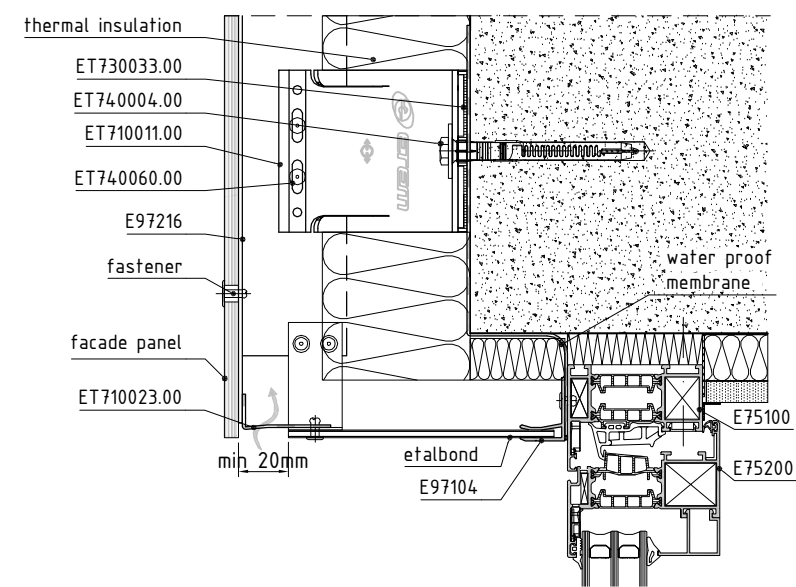

5

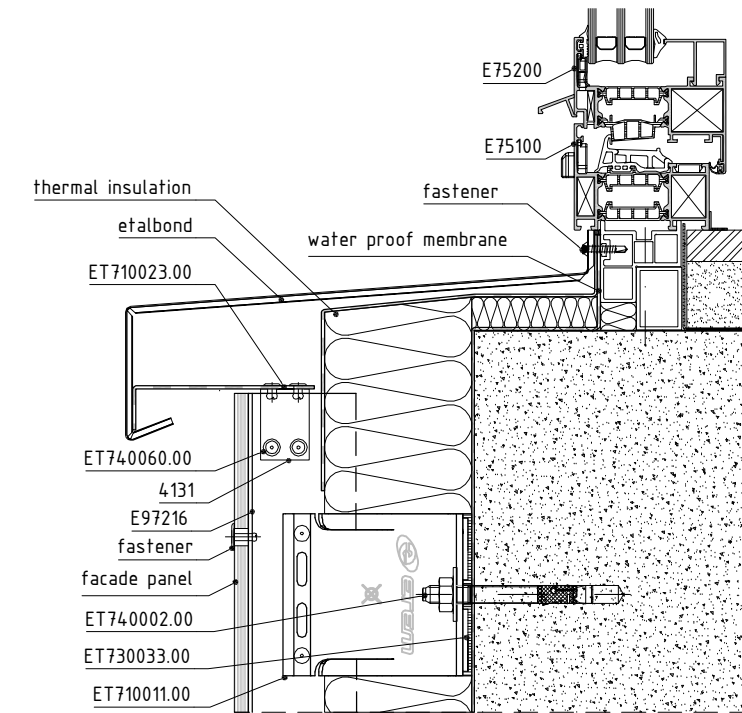

6

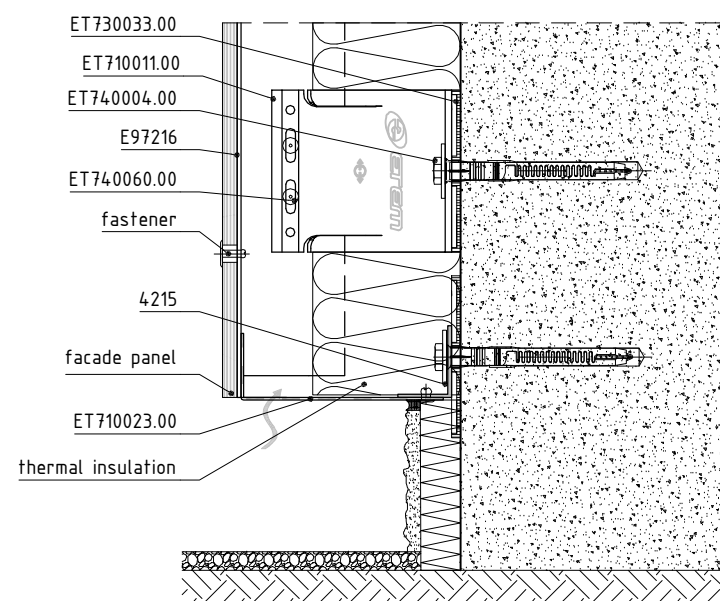

7

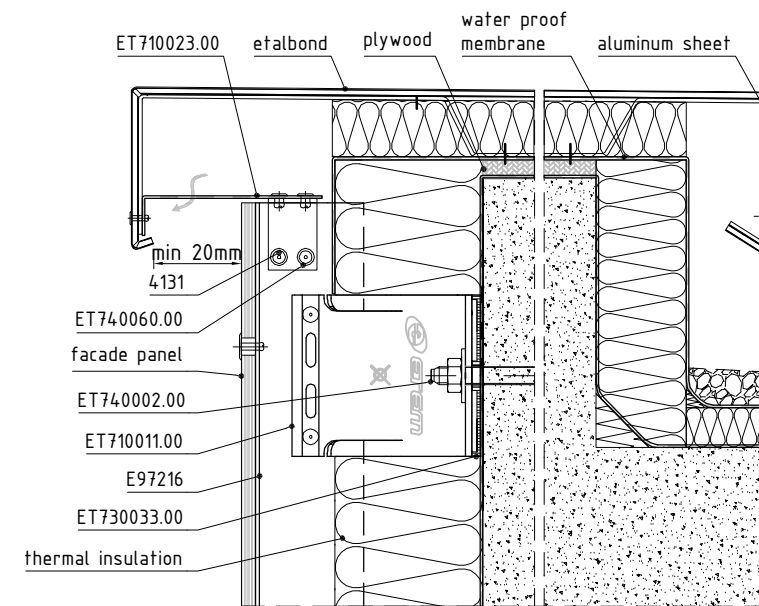

8

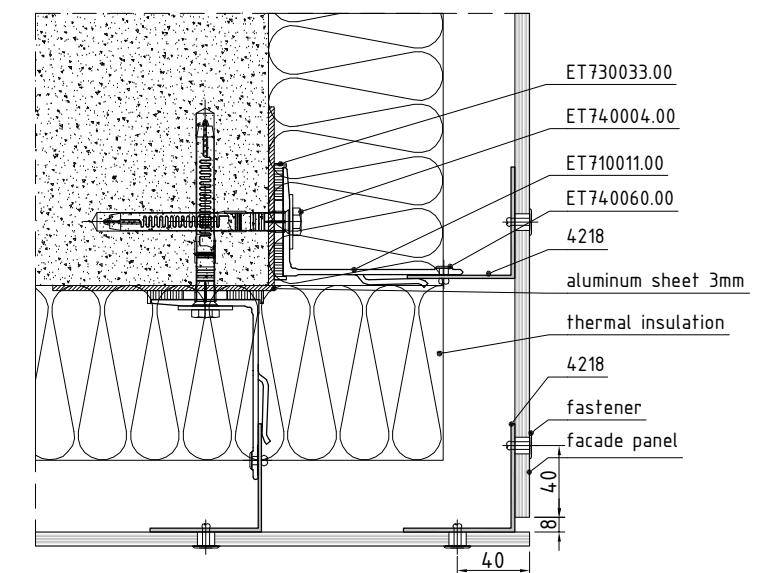

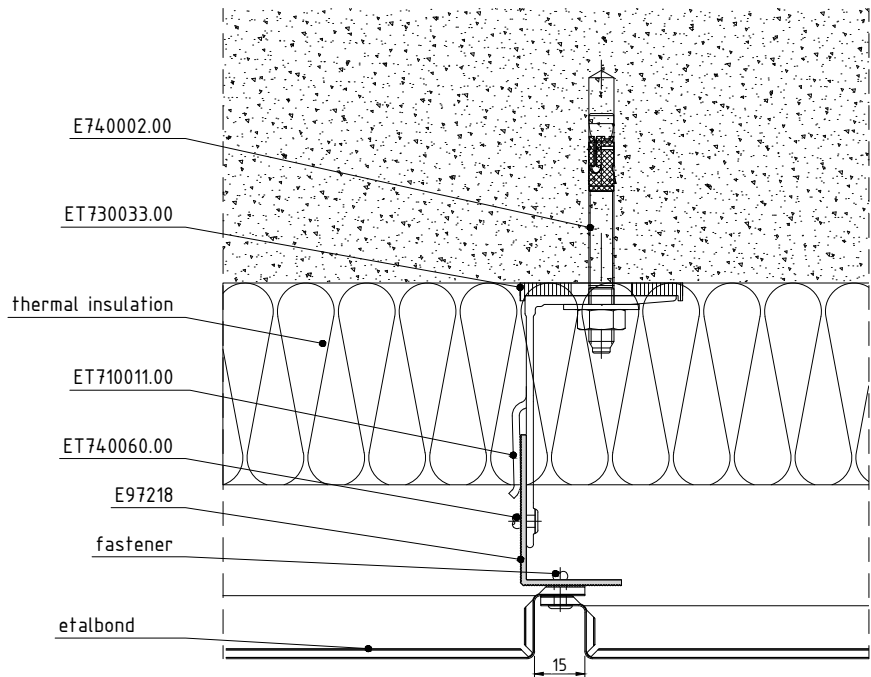
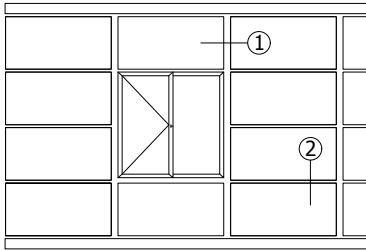

①

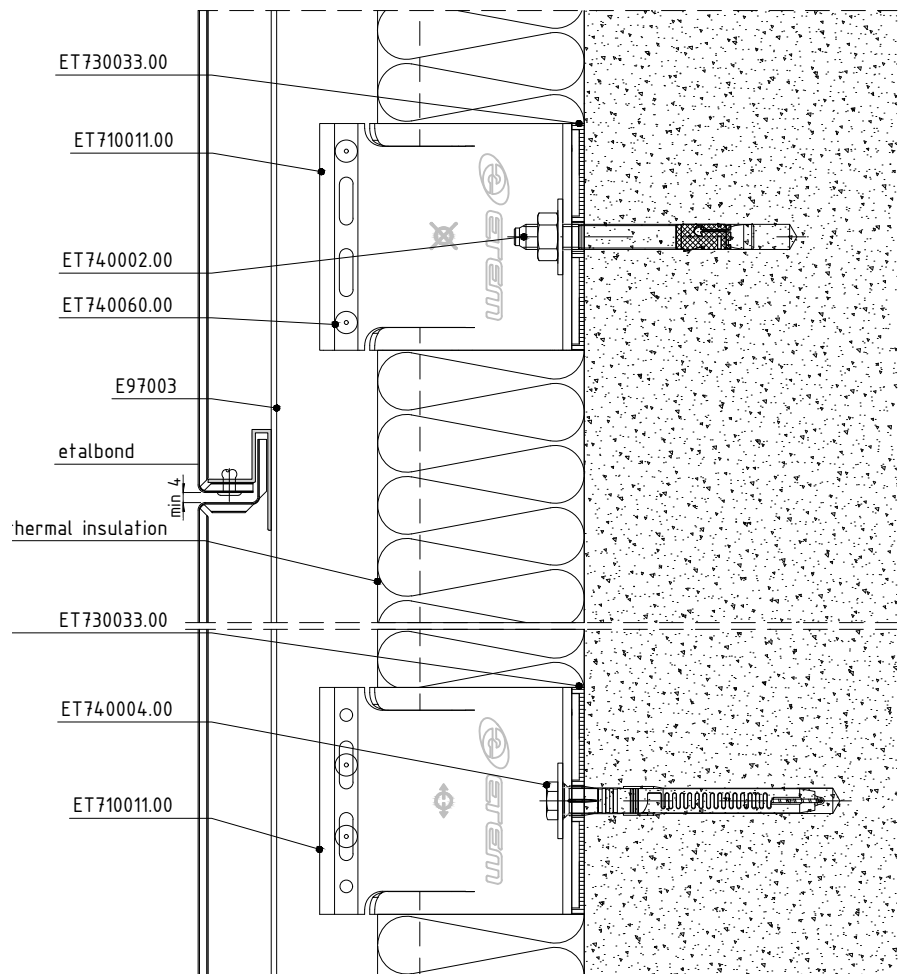

②

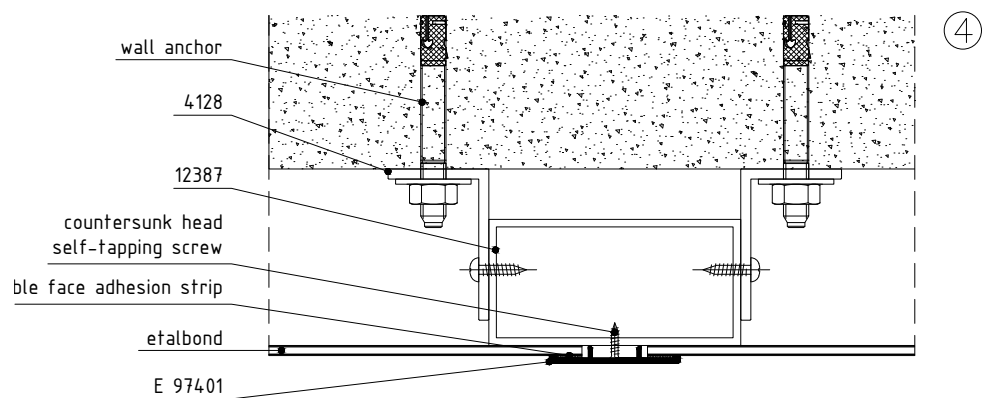
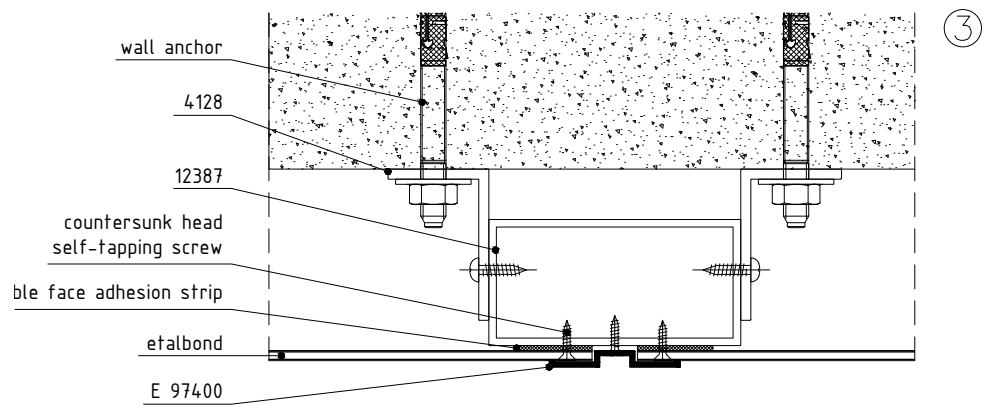
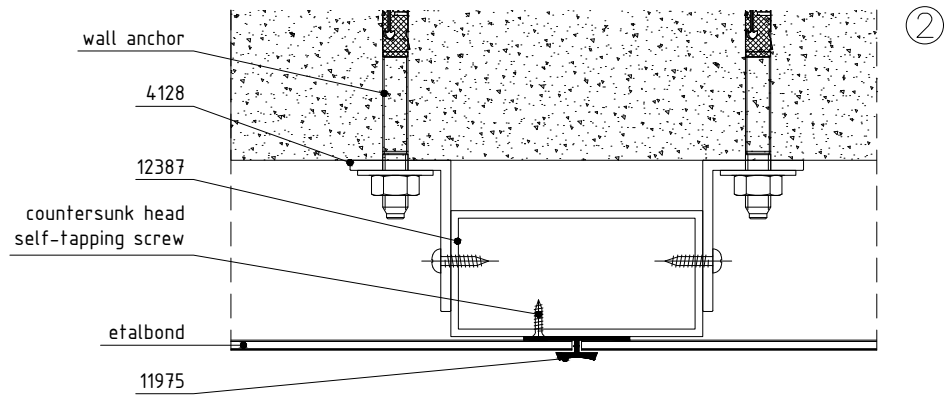
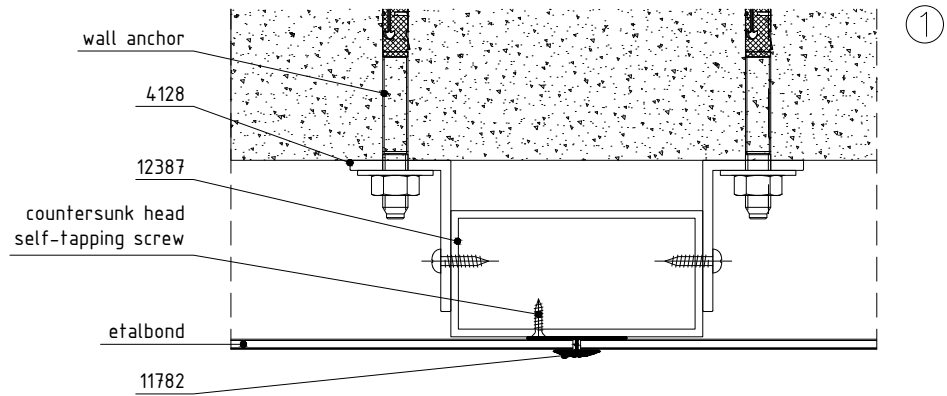
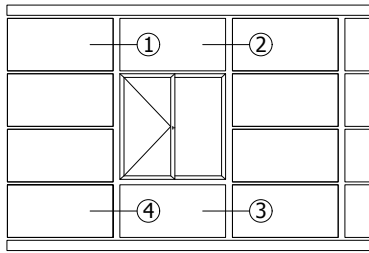

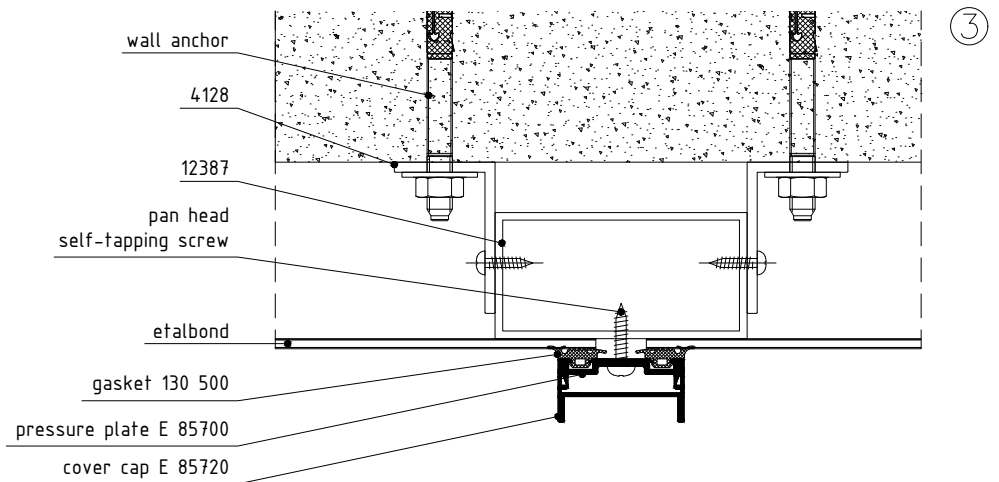
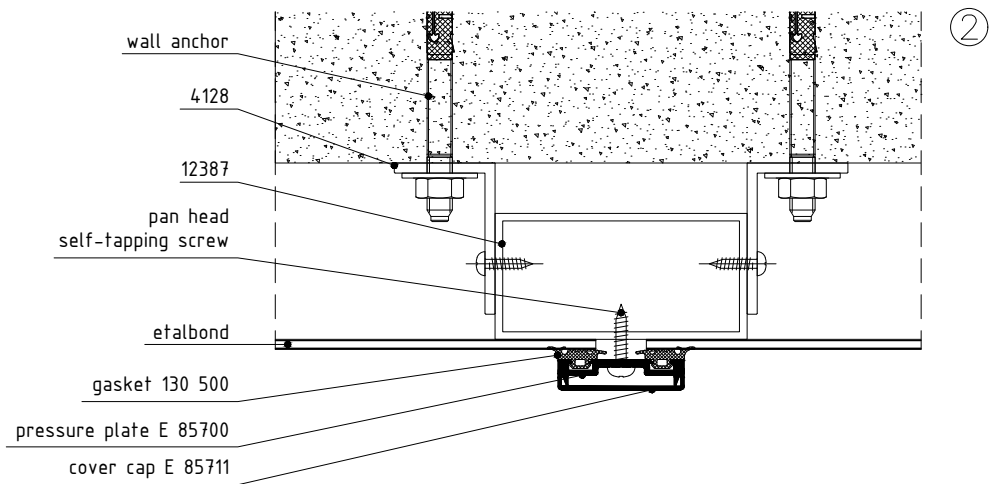
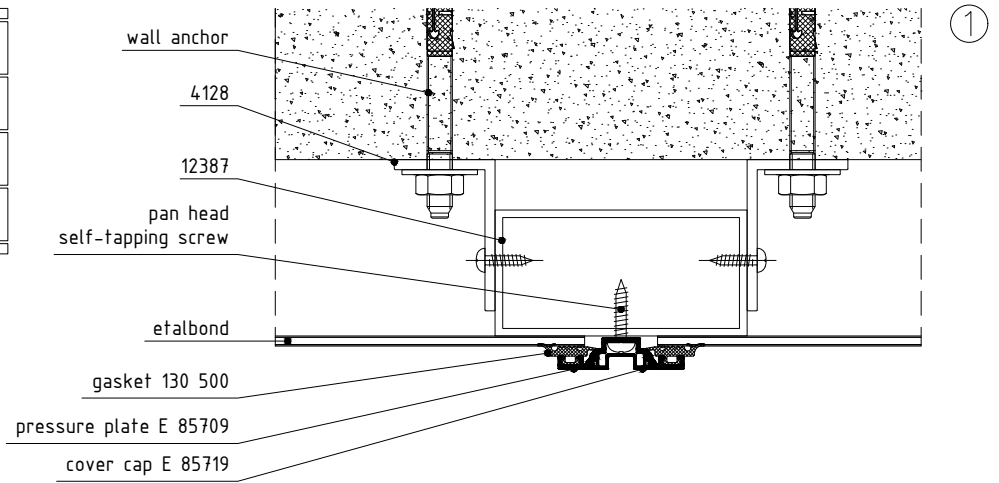
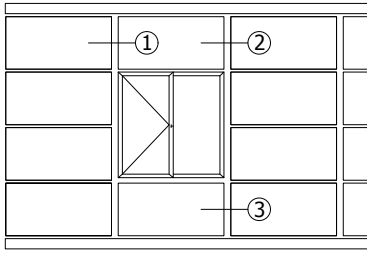

note: wide variety of combinations with E85 curtain wall system profiles are available, thus retaining the raster pattern of the façade



VARIO Clips

VARIO CLIPS IS USED FOR MOUNTING OF THIN AND SMOOTH FAÇADE MATERIALS BY USING CLIPS. SPECIALLY DESIGNED PROFILES AND ACCESSORIES ALLOW SECURE INSTALLATION OF FLAT FAÇADE MATERIALS SUCH AS: HPL PANELS, GLASS, LIGHT STONES AND CERAMIC WITH THICKNESS LESS THAN 12 MM.











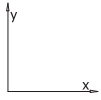
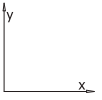

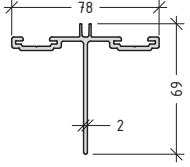

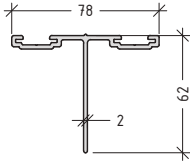

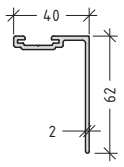

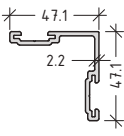

MAIN ADVANTAGES:

- fast and accurate installation without using special equipment
- easier alignment of vertical joints between the tiles through the main vertical profile
- possibility of coatings in different colours of the visible part of the profile that matches the façade material
- the possibility for the production of profiles, which allows mounting of materials with different heights
- possibility for production of basic profiles in different lengths
- clips coated in wide range of colours

CLADDING MATERIALS: Ceramic Tiles, Glass, High Pressure Laminates (HPL), Fibre Cement, Stone, Technical Stone, Composite Mineral Material, Glass Fiber Reinforced Concrete GFRC, GREP, Light Transmitting Concrete

VARIO Clips

E97

code		profile	weight length moment of inertia	code		profile	weight length moment of inertia
E 97209 TR* main profile			1015 g/m L=6.01 m Ix=10.55 cm ⁴ Iy=13.79 cm ⁴	ET720046.00 bottom clips			pcs 1
E 97210 TR* main profile			973 g/m L=6.01 m Ix=10.15 cm ⁴ Iy=13.78 cm ⁴	ET720044.00 upper clips			pcs 1
E 97211 TR* main profile			653 g/m L=6.01 m Ix=8.52 cm ⁴ Iy=4.25 cm ⁴	ET720047.00 end clips			pcs 1
E 97212 TR* main profile			731 g/m L=6.01 m Ix=6.11 cm ⁴ Iy=6.11 cm ⁴	gaskets for 6mm glass thickness			
				for end clip	for middle up and bottom clip	for middle down and upper clip	
							1 m
				ET130765.00	ET130766.00	ET130767.00	
ET770001.00 EPDM gasket			1000mm length	gaskets for 8mm glass thickness			
				for end clip	for middle up and bottom clip	for middle down and upper clip	
							1 m
				ET130781.00	ET130782.00	ET130783.00	
ET720045.00 middle clips			pcs 1	gaskets for 10mm glass thickness			
				for end clip	for middle up and bottom clip	for middle down and upper clip	
							1 m
				ET130759.00	ET130760.00	ET130761.00	

note: TR abbreviation stands for additional treatments (pre-punched rectangular holes, etc.). All additional treatments must be accompanied by approved drawings.

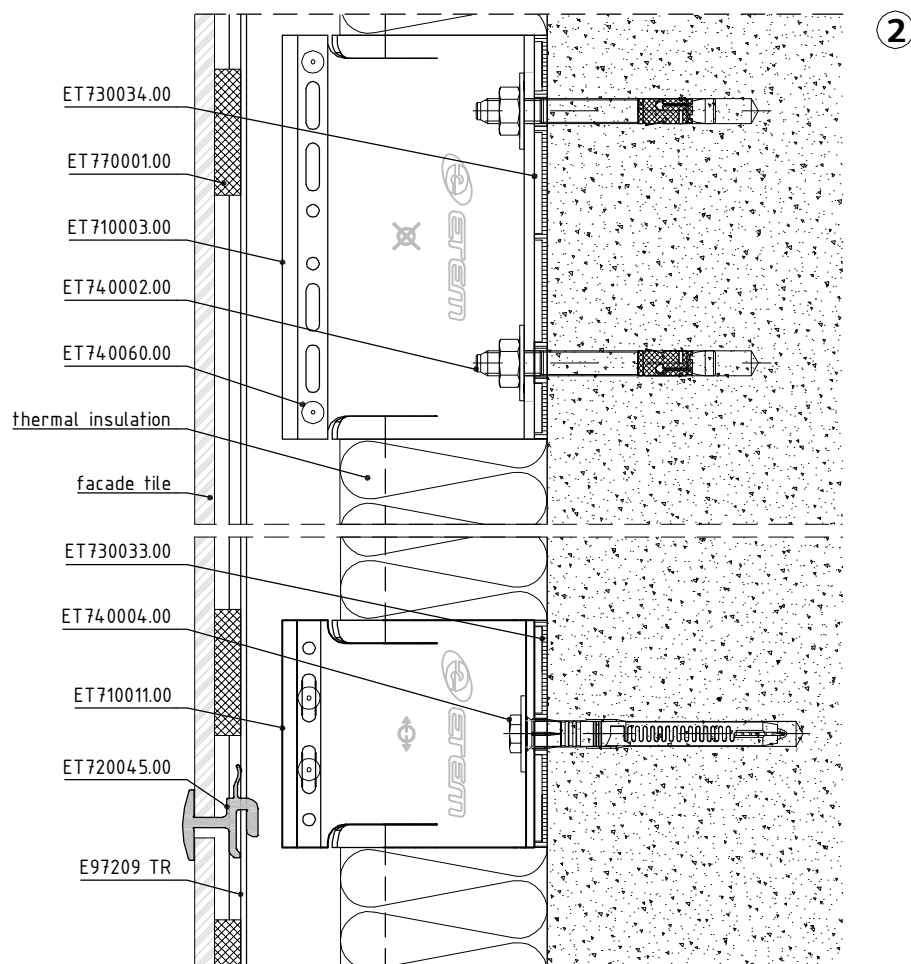
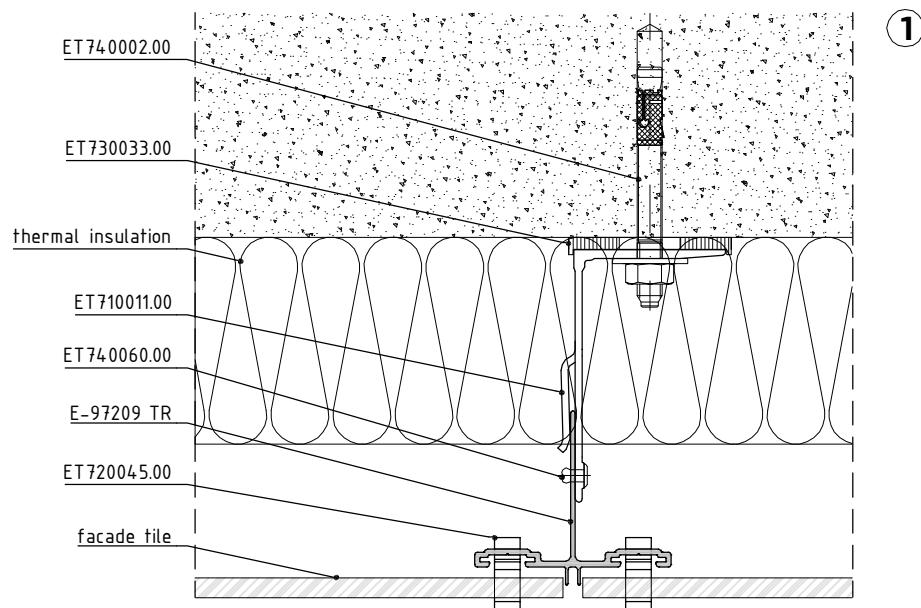
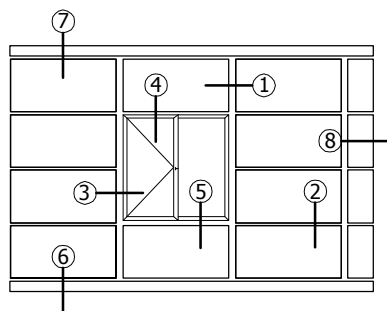

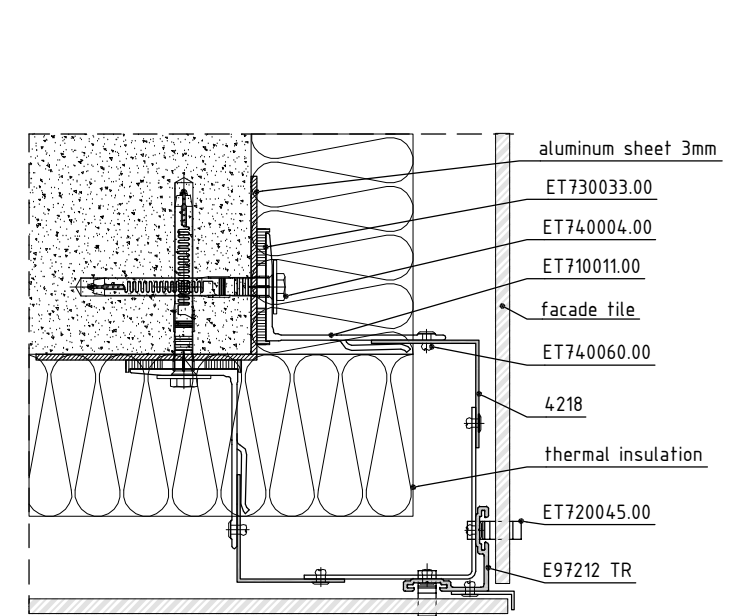
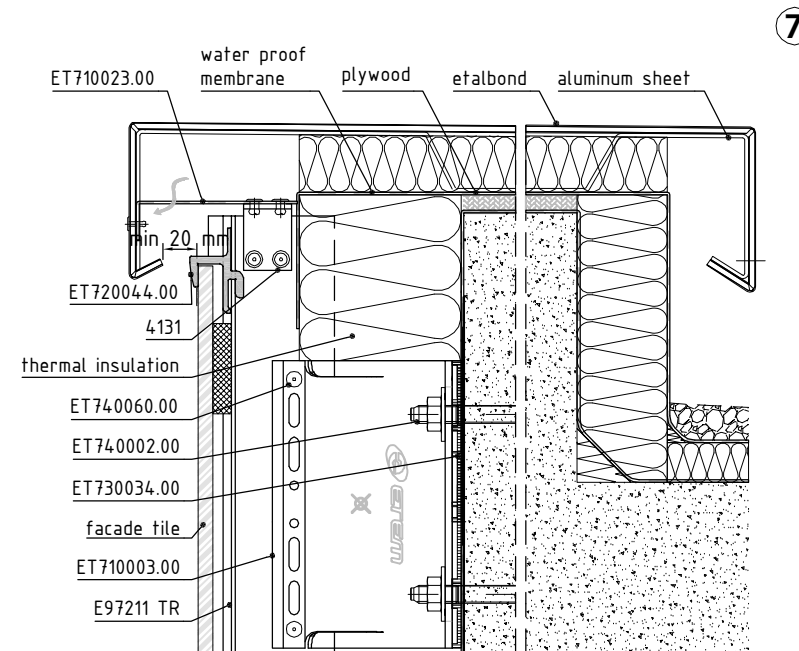
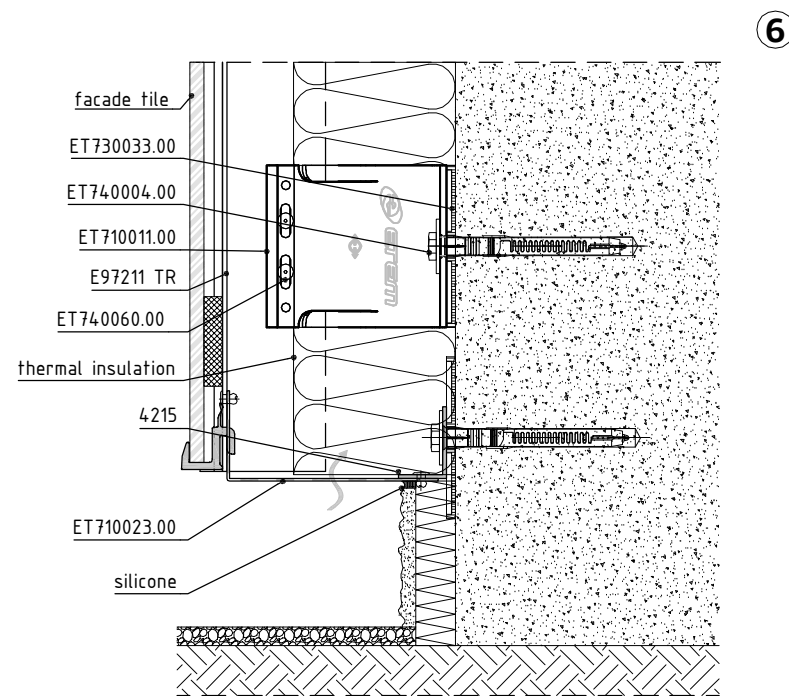
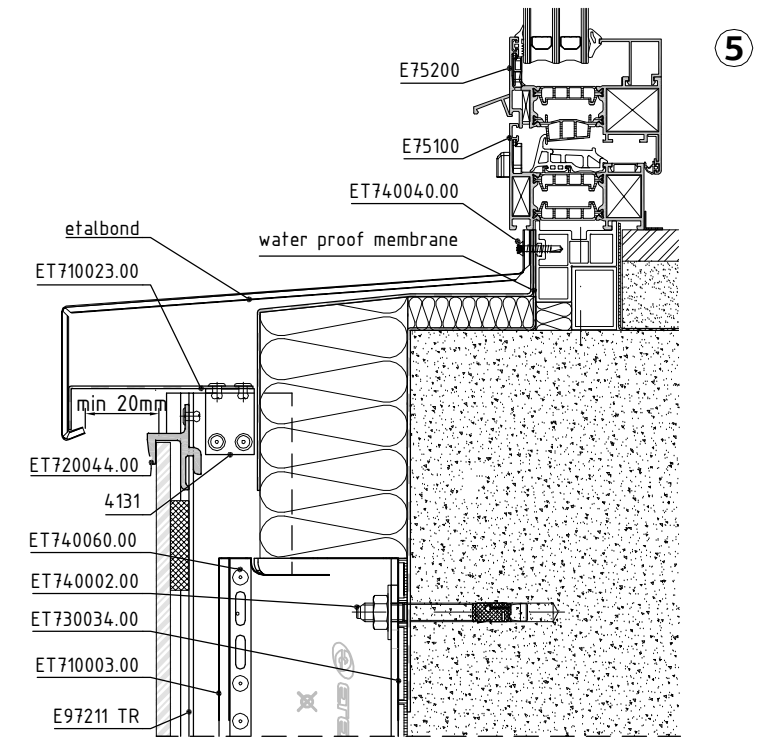
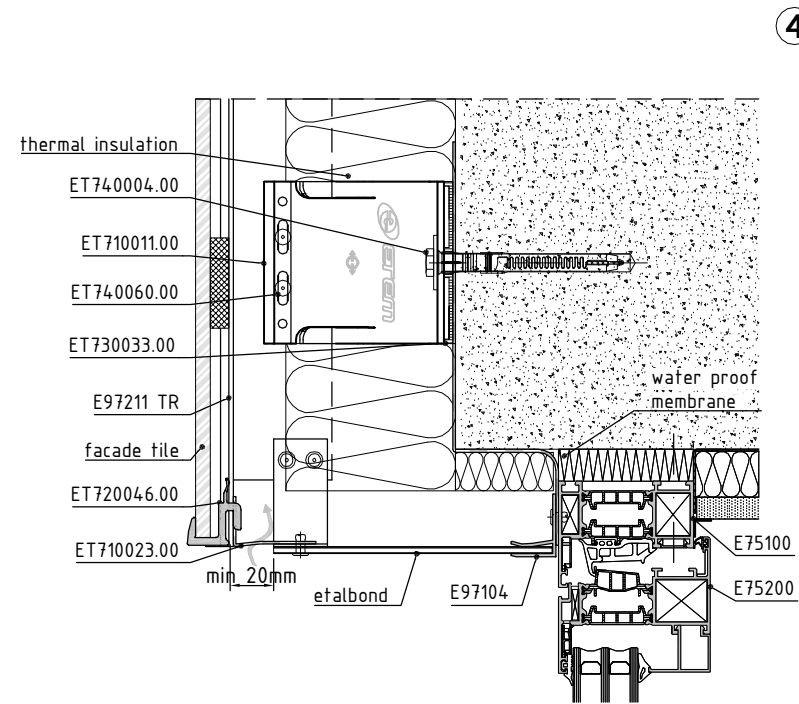
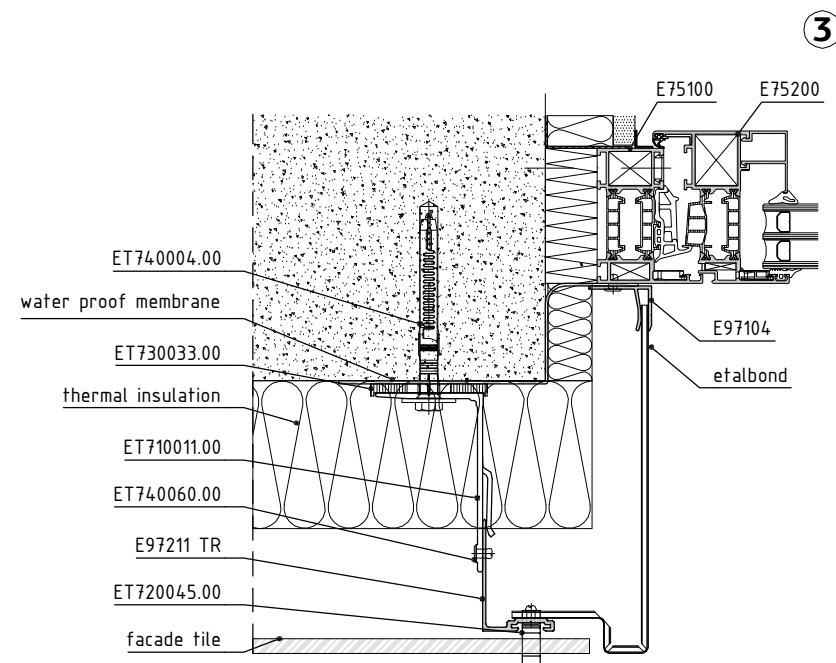

FORTE

FORTE Light / FORTE / FORTE Pins

WEBAU



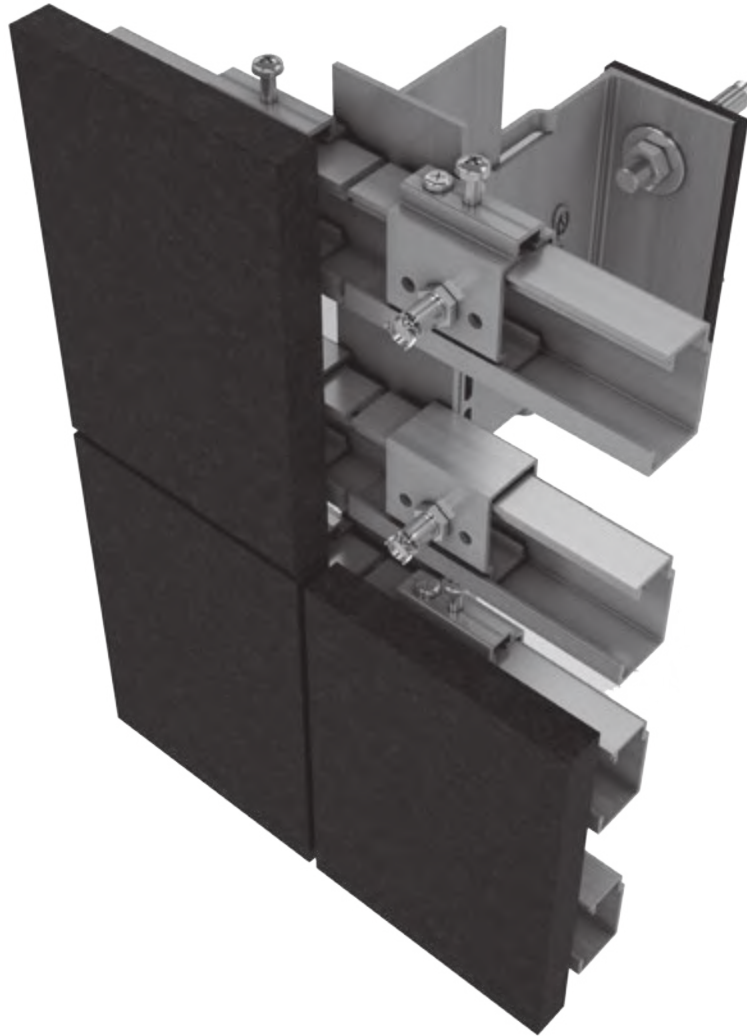





FORTE Light

FORTE LIGHT IS DESIGNED FOR INVISIBLE MOUNTING OF THIN AND SMOOTH FAÇADE MATERIALS THROUGH fischer® OR KEIL® UNDERCUT ANCHORS. THE UNDERCUT ANCHORS, SYSTEM ACCESSORIES, AND DESIGNED PROFILES ALLOW SECURE MOUNTING OF HPL, FIBRE CEMENT, CERAMICS, AND STONE WITH LESS THAN 25 MM THICKNESS. FORTE LIGHT VENTILATED SYSTEM USES fischer® OR KEIL® FIXING ANCHORS TO GUARANTEE THE CONNECTIONS BETWEEN THE FAÇADE MATERIAL AND THE MAIN PROFILES OF THE SYSTEM.

MAIN ADVANTAGES:

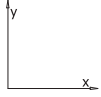
- perfect vision of the façade with no visible holding elements; large variety of sizes and designs of the façade materials
- highest level of security when fixing the tiles, due to the fischer® and KEIL® undercut anchors
- possibility to use façade materials with thickness ranging from 10 mm to 25 mm
- fast and easy installation - 1.5 sq.m. per person per hour
- secure and fully engineered work, which covers the entire project, and guarantees a complete system solution

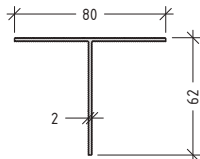
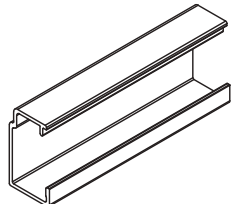
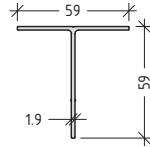
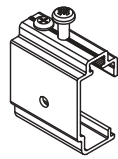
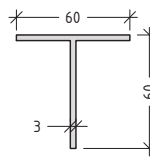
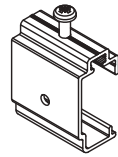
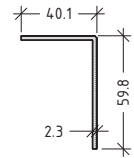
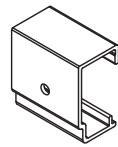
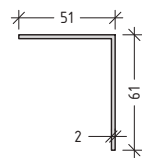
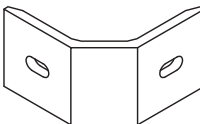
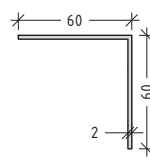
CLADDING MATERIALS: Ceramic Tiles, Glass, High Pressure Laminates (HPL), Fibre Cement, Stone, Technical Stone, Composite Mineral Material, Glass Fiber Reinforced Concrete GFRC, GREP, Light Transmitting Concrete

code		profile	weight length moment of inertia	code		profile	weight length moment of inertia
E 97004 main profile grooved		646 g/m L=6.01 m $I_x=8.67 \text{ cm}^4$ $I_y=7.26 \text{ cm}^4$	E 97914 E 97914 horizontal profile		L=6.01 m 1000mm length		
E 97003 main profile		603 g/m L=6.01 m $I_x=7.78 \text{ cm}^4$ $I_y=3.25 \text{ cm}^4$	ET720093.00 - for KEIL® undercut anchors ET720041.00 - for Fischer® undercut anchors adjustable hanger for fixed support		pcs 1 Note: set including fastening elemens		
E 97301 main profile		951 g/m L=6.01 m $I_x=12.54 \text{ cm}^4$ $I_y=5.41 \text{ cm}^4$	ET720094.00 - for KEIL® undercut anchors ET720043.00 - for Fischer® undercut anchors adjustable hanger for flexible support		pcs 1 Note: set including fastening elemens		
E 97218 main profile grooved		567 g/m L=6.01 m $I_x=2.96 \text{ cm}^4$ $I_y=7.92 \text{ cm}^4$	ET720095.00 - for KEIL® undercut anchors ET720042.00 - for Fischer® undercut anchors hanger for flexible support		pcs 1		
4049 main profile		596 g/m L=6.01 m $I_x=5.50 \text{ cm}^4$ $I_y=8.52 \text{ cm}^4$	ET710040.00 corner joint profile		pcs 1		
4218 main profile		640 g/m L=6.01 m $I_x=8.56 \text{ cm}^4$ $I_y=8.56 \text{ cm}^4$	ET740012.00 undercut anchor		pcs 1		

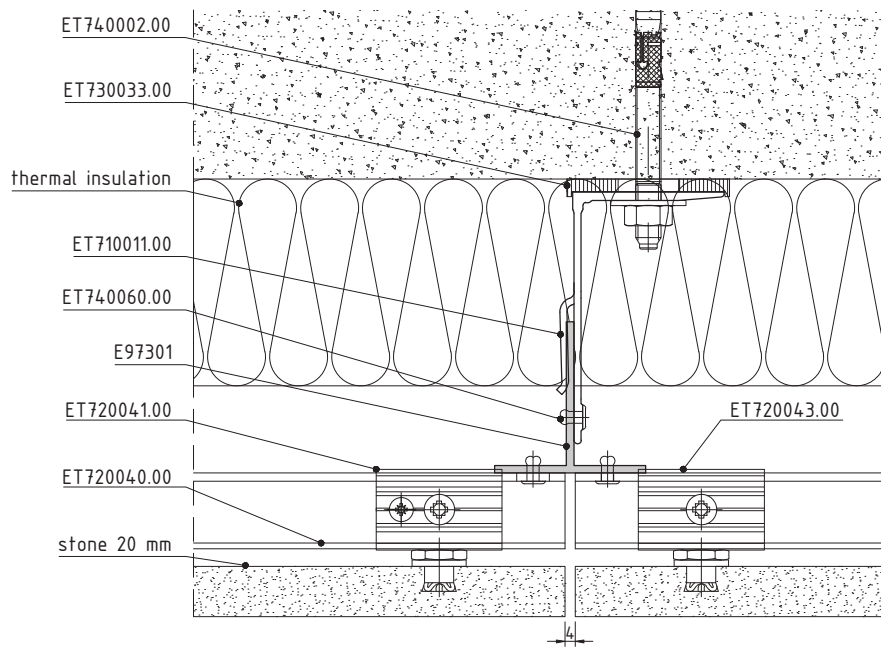
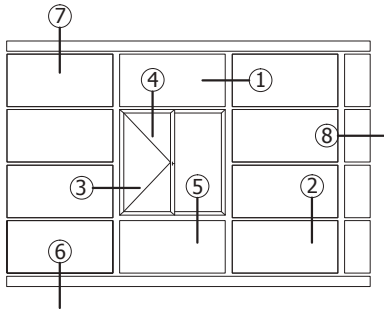

1

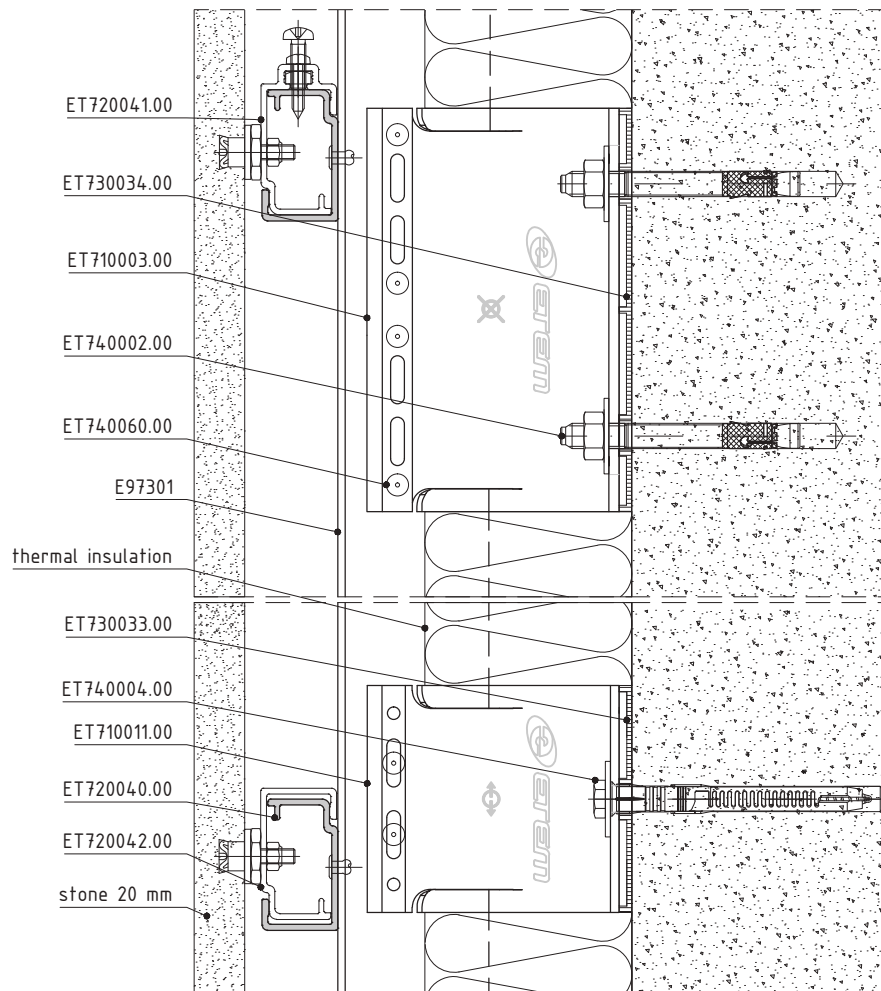

2

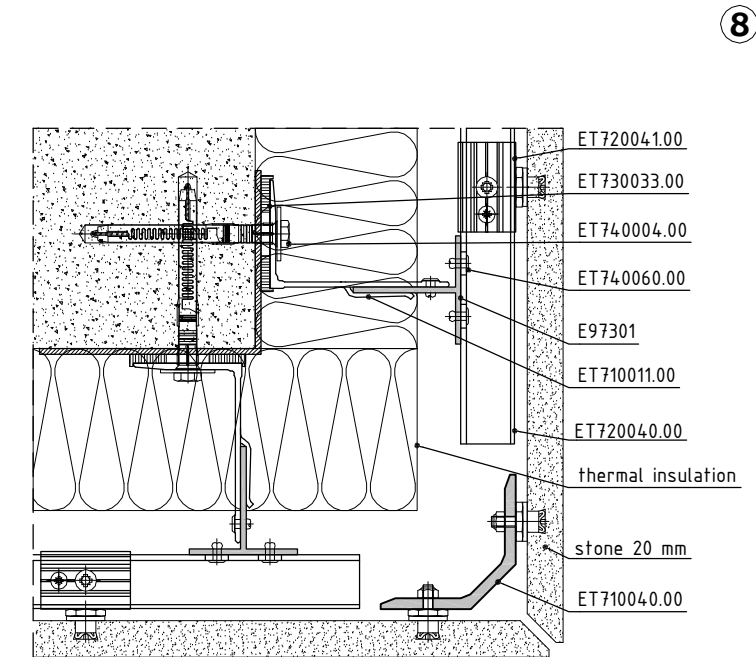
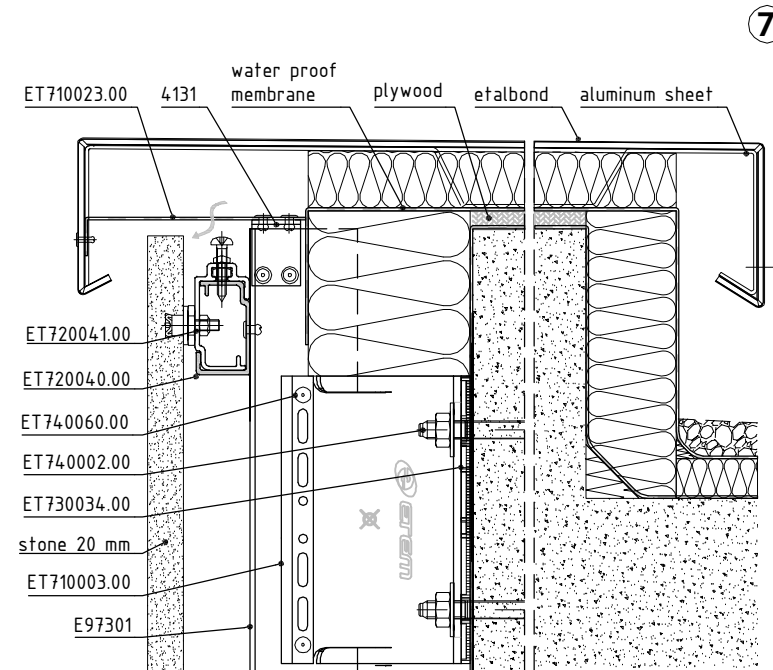
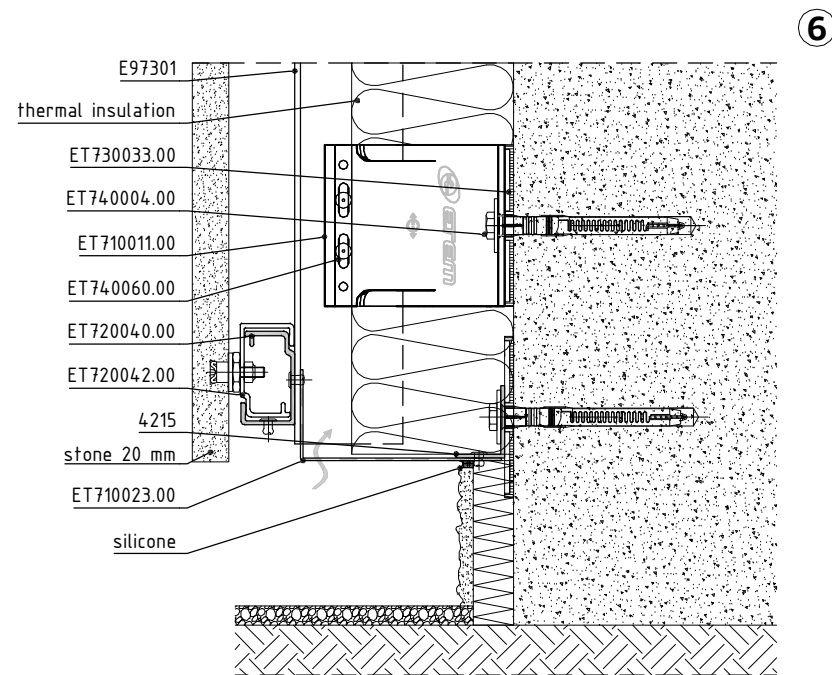
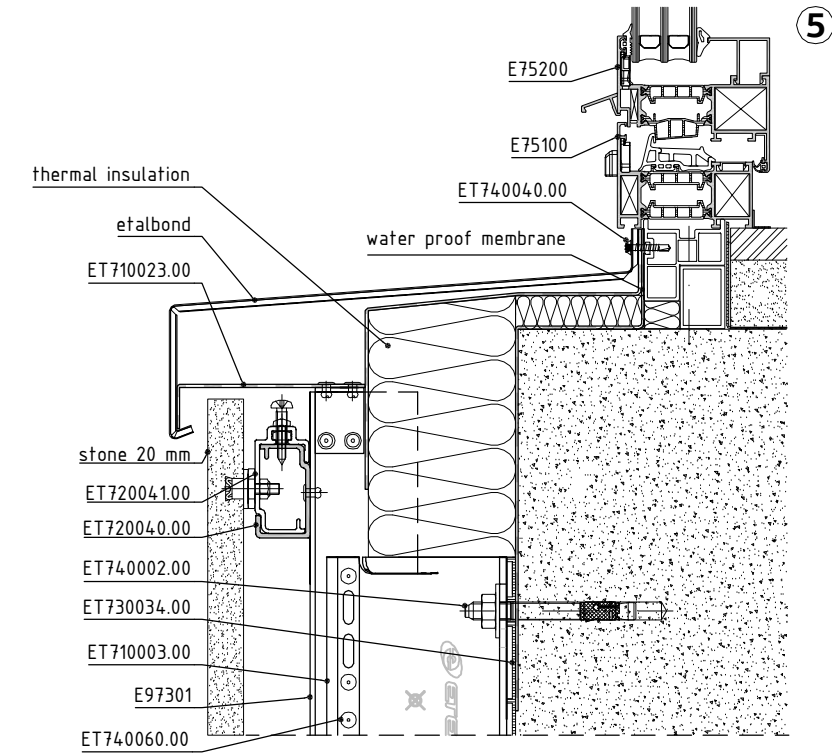
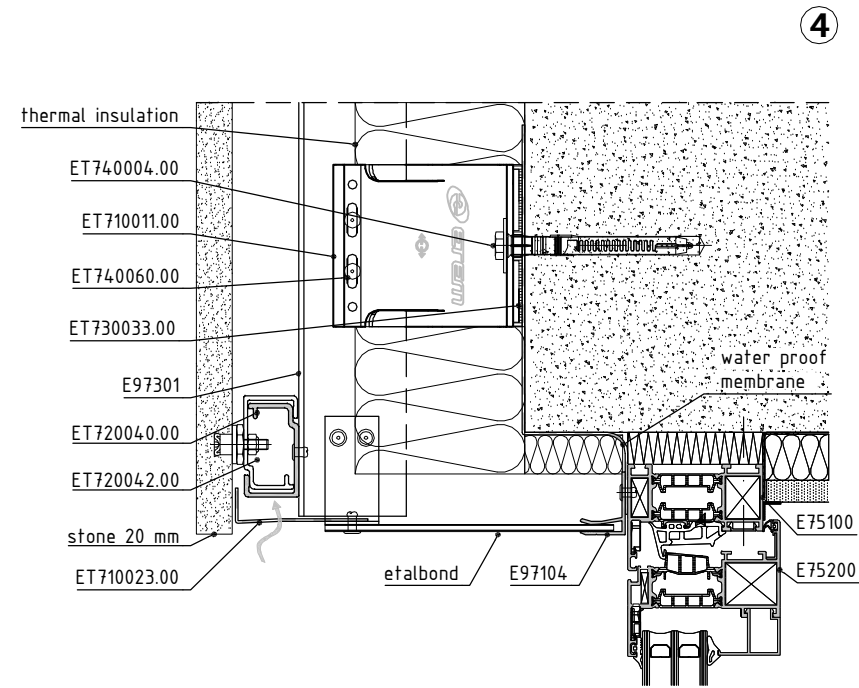
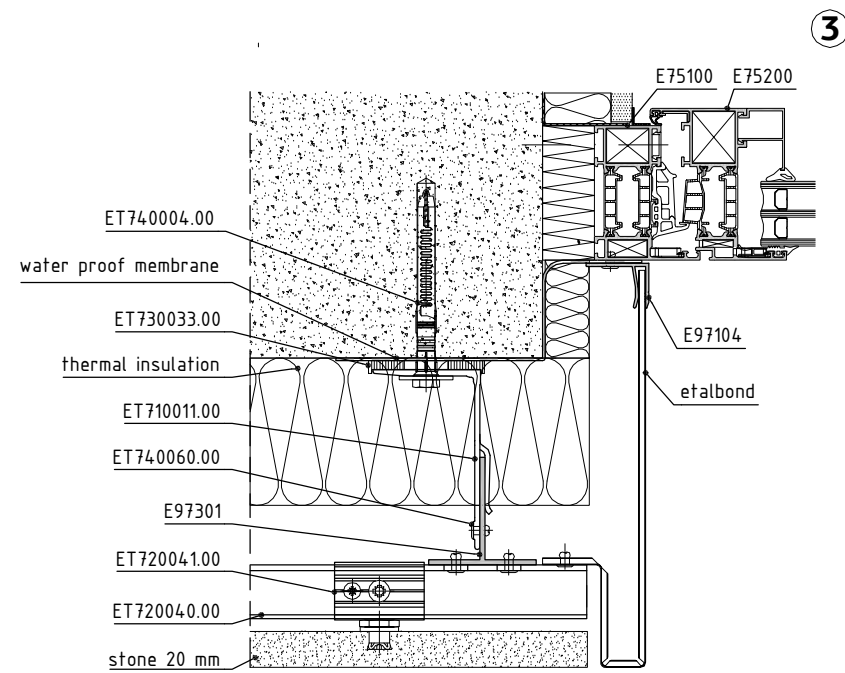

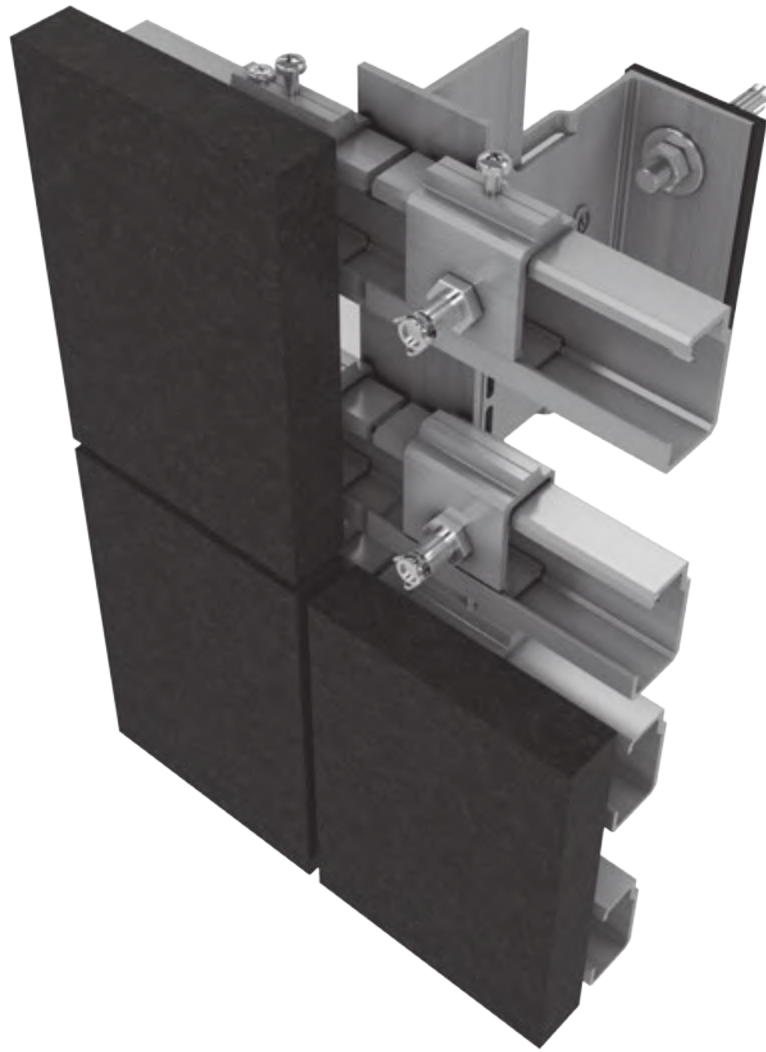





FORTE

THE SYSTEM IS DESIGNED FOR MOUNTING HEAVY FAÇADE MATERIALS WITH THICKNESS MORE THAN 25 MM. THE PROFILES AND ACCESSORIES ARE CONSTRUCTED TO BEAR EXTREME PRESSURES, CAUSED BY FAÇADE MATERIALS WITH WEIGHTS UP TO 90 KG PER SQ.M. FORTE VENTILATED SYSTEM USES fischer® FIXING ANCHORS TO GUARANTEE THE CONNECTIONS BETWEEN THE FAÇADE MATERIAL AND THE MAIN BEARING STRUCTURE OF THE SYSTEM. IT IS AN UNIQUE UNDERCUT TECHNOLOGY FOR DRILLING AND MOUNTING OF THE ANCHOR ON THE BACK (INVISIBLE) SECTION OF THE FAÇADE MATERIAL.

MAIN ADVANTAGES:

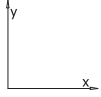
- perfect vision of the façade with no visible holding elements
- large variety of sizes and designs of the façade materials
- highest level of security when fixing the plates due to the fischer® undercut anchors
- possibility to use façade materials with thickness ranging from 25 mm to more than 35 mm
- fast and easy installation

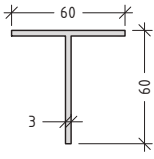
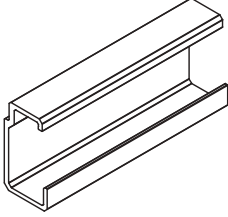
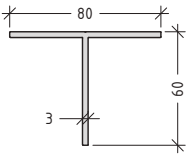
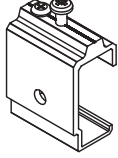
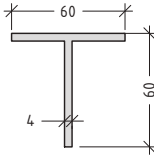
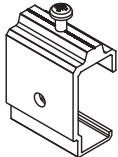
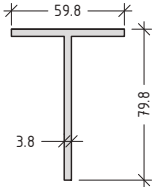
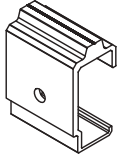
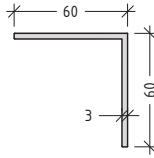
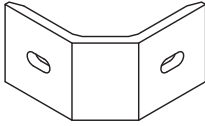
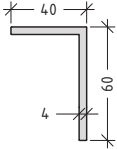
CLADDING MATERIALS: Ceramic Tiles, Stone, Technical Stone, Light Transmitting Concrete

code		profile	weight length moment of inertia	code		profile	weight length moment of inertia
E 97301 main profile			951 g/m L=6.01 m $I_x=12.54 \text{ cm}^4$ $I_y=5.41 \text{ cm}^4$	ET7911 E 97911 horizontal profile			L=6.01 m 1000mm length
E 97302 main profile			1113 g/m L=6.01 m $I_x=13.63 \text{ cm}^4$ $I_y=12.80 \text{ cm}^4$	ET720081.00 adjustable hanger for fixed support			pcs 1 Note: set including fastening elemens
17160 main profile			1257 g/m L=6.01 m $I_x=16.31 \text{ cm}^4$ $I_y=7.23 \text{ cm}^4$	ET720083.00 adjustable hanger for flexible support			pcs 1 Note: set including fastening elemens
TP060001 main profile			1404 g/m L=6.01 m $I_x=34.17 \text{ cm}^4$ $I_y=6.81 \text{ cm}^4$	ET720082.00 hanger for flexible support			pcs 1
4163 main profile			1404 g/m L=6.01 m $I_x=12.53 \text{ cm}^4$ $I_y=12.53 \text{ cm}^4$	ET710080.00 corner joint profile			pcs 1
4128 main profile			1040 g/m L=6.01 m $I_x=14.27 \text{ cm}^4$ $I_y=5.18 \text{ cm}^4$	ET740027.00 undercut anchor			pcs 1

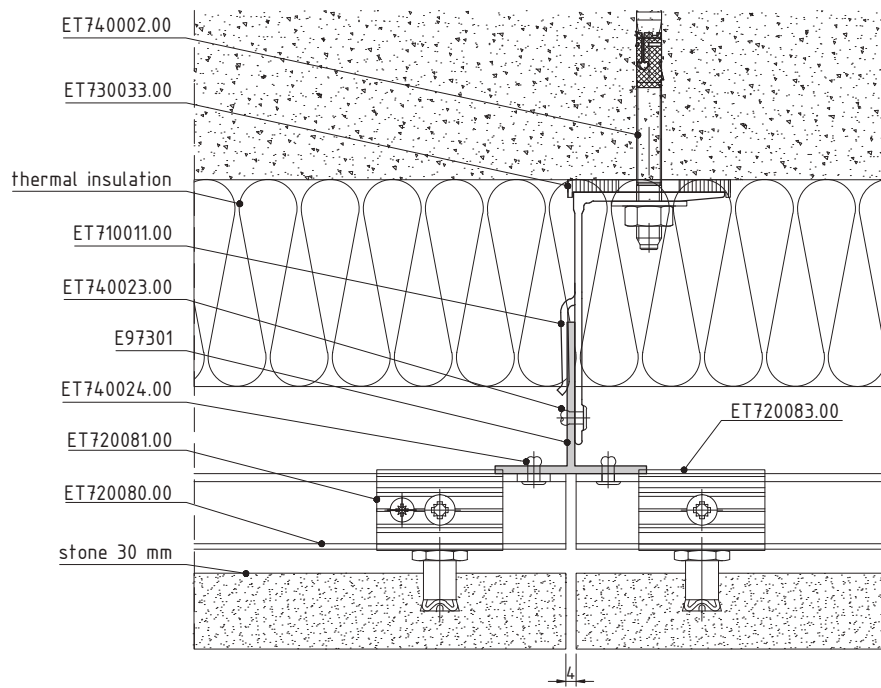
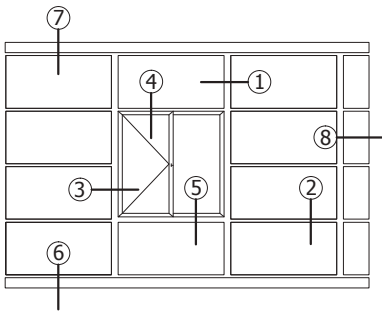

1

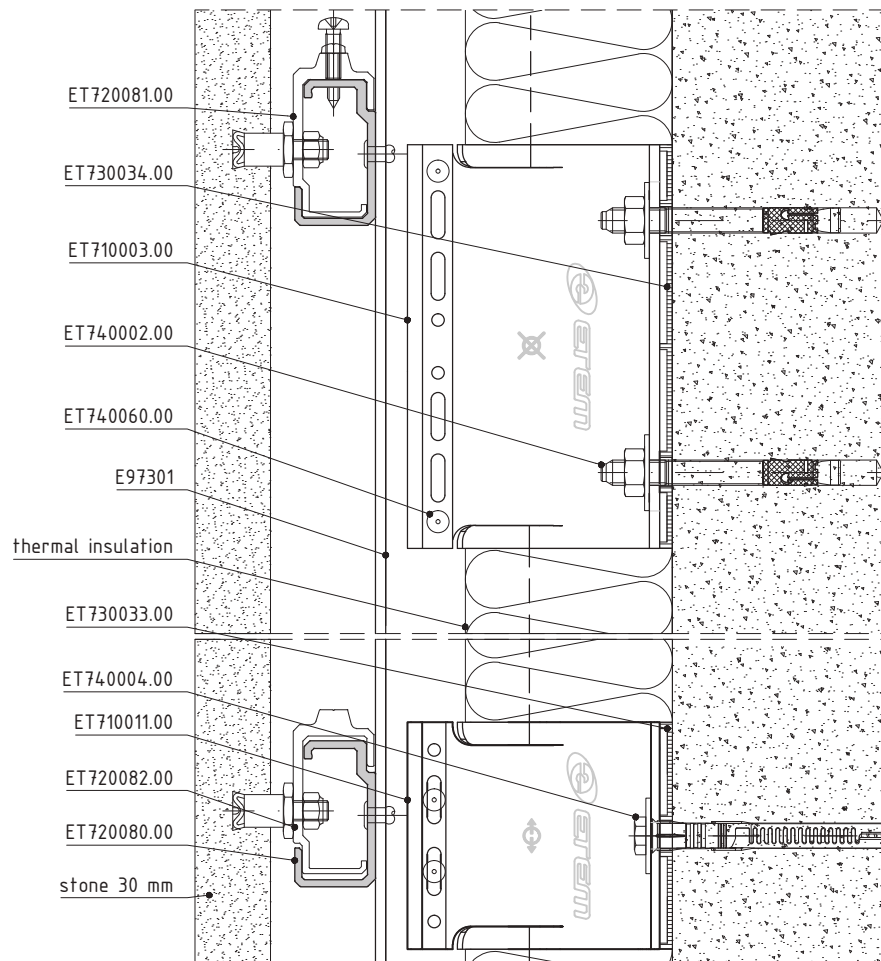

2

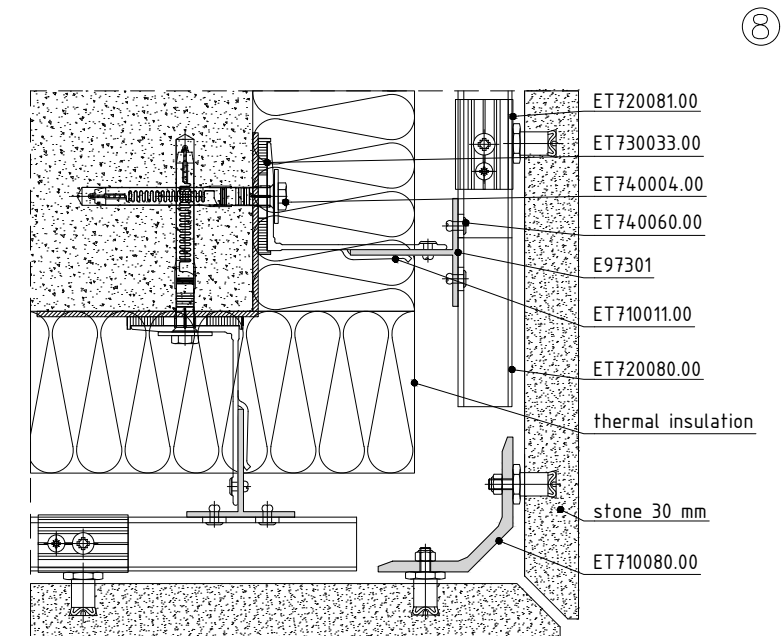
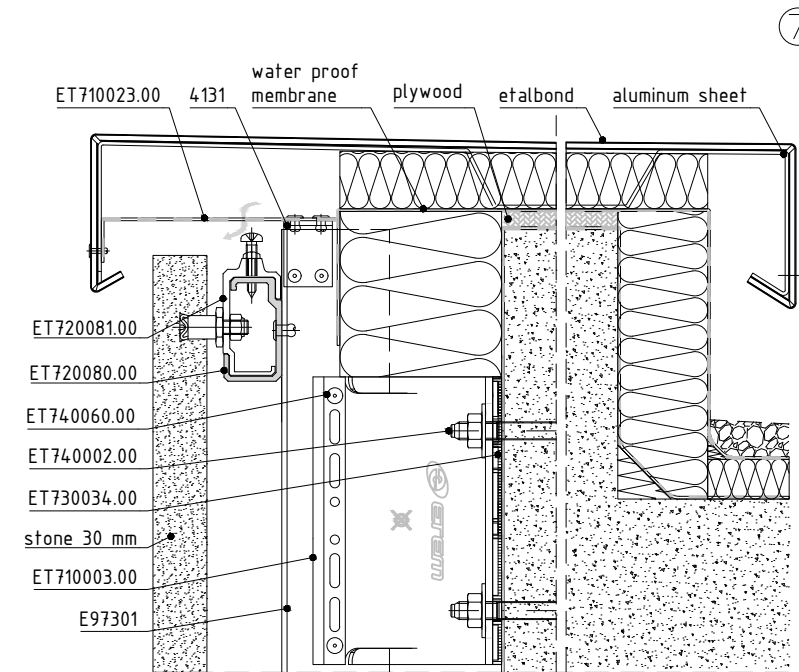
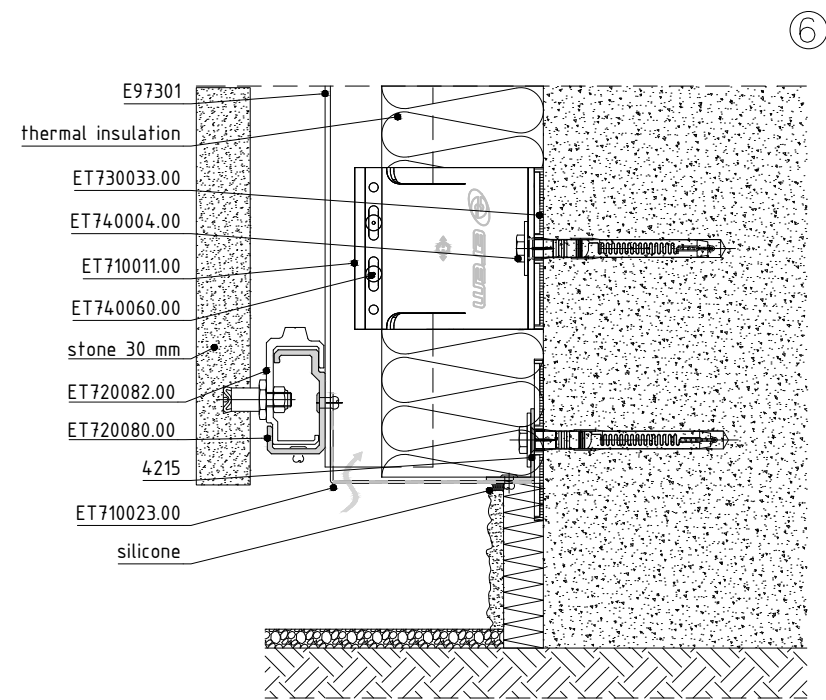
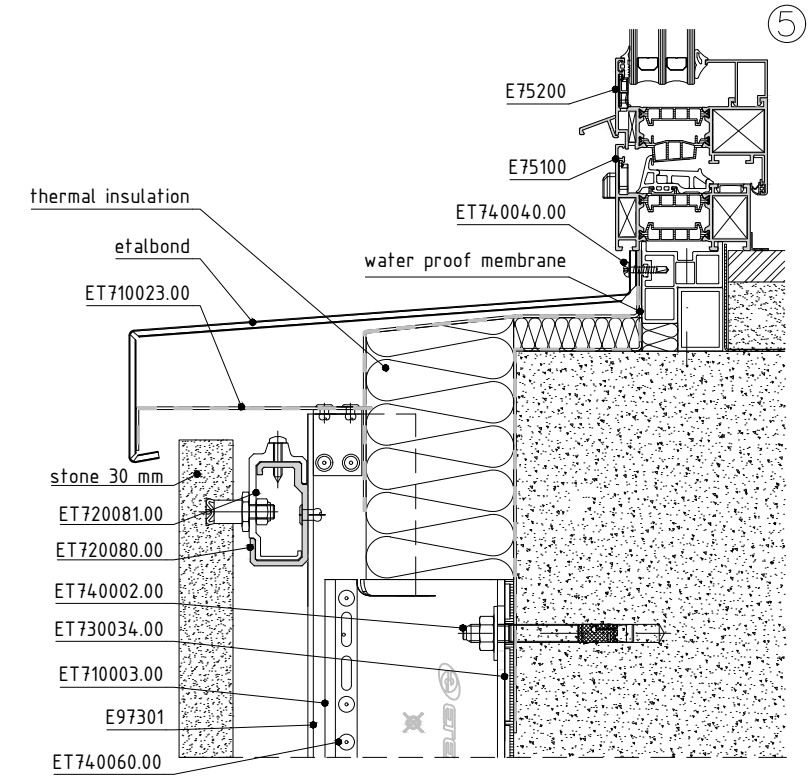
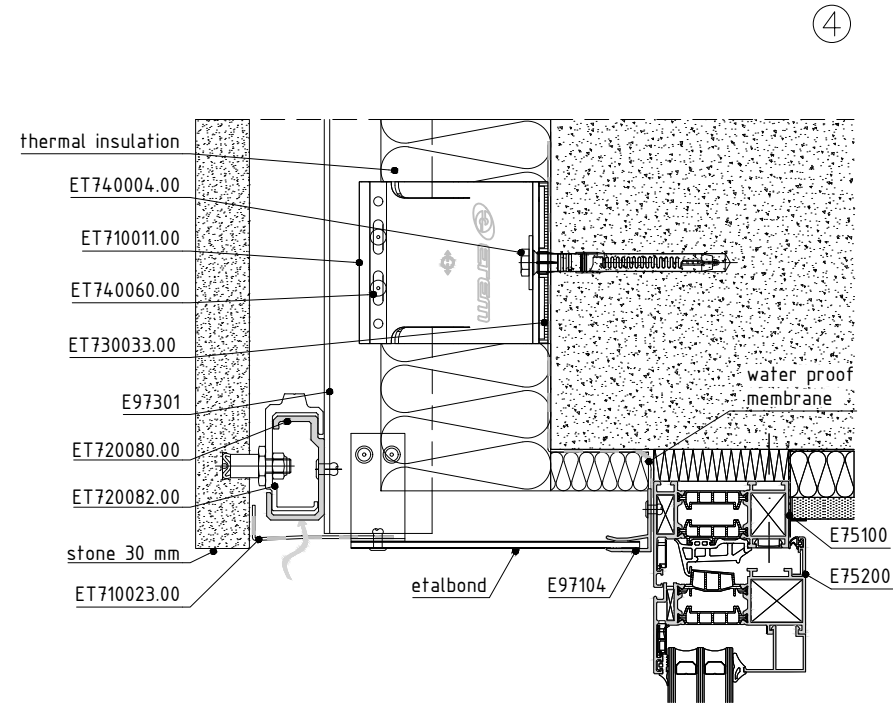
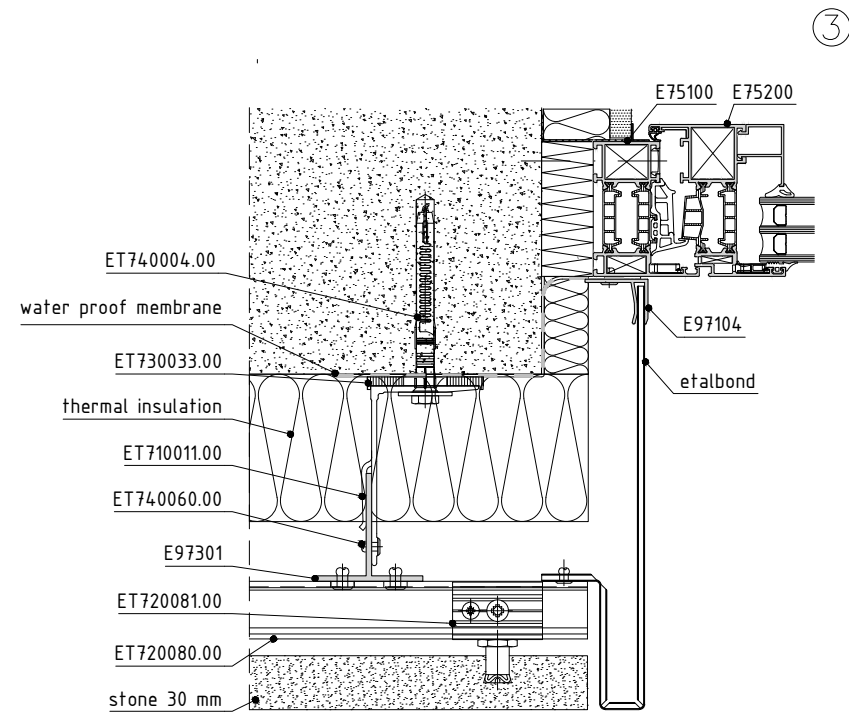



FORTE Pins

THE SYSTEM IS DESIGNED FOR MOUNTING OF HEAVY FAÇADE MATERIALS WITH THICKNESS MORE THAN 30 MM. THE PROFILES AND ACCESSORIES ARE DESIGNED TO HANDLE EXTREME LOADS, CAUSED BY THE WEIGHT OF FAÇADE MATERIALS UP TO 90 KG/SQ.M.

MAIN ADVANTAGES:

- fast, easy and secure mounting of heavy stones
- optimization of the substructure by optimal load distribution to vertical supporting pillars

Materials suitable for hanging:





- stone
- marble

Mounting method: stainless steel pins

CLADDING MATERIALS: Stone, Technical Stone, Light Transmitting Concrete

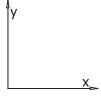
FORTE Pins

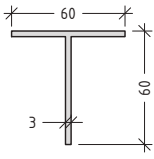
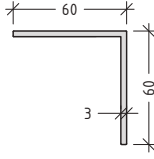
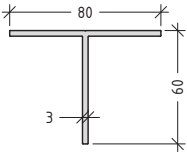
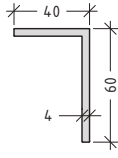
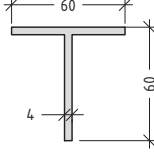
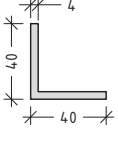
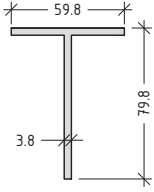
E97

code		profile	weight length moment of inertia	code		profile	weight length moment of inertia
E 97301 main profile			951 g/m L=6.01 m $I_x=12.54 \text{ cm}^4$ $I_y=5.41 \text{ cm}^4$	4163 main profile			951 g/m L=6.01 m $I_x=12.53 \text{ cm}^4$ $I_y=12.53 \text{ cm}^4$
E 97302 main profile			1113 g/m L=6.01 m $I_x=13.63 \text{ cm}^4$ $I_y=12.80 \text{ cm}^4$	4128 main profile			1040 g/m L=6.01 m $I_x=14.27 \text{ cm}^4$ $I_y=5.18 \text{ cm}^4$
17160 main profile			1257 g/m L=6.01 m $I_x=16.31 \text{ cm}^4$ $I_y=7.23 \text{ cm}^4$	4138 horizontal profile			824 g/m L=6.01 m $I_x=4.61 \text{ cm}^4$ $I_y=4.61 \text{ cm}^4$
TP060001 main profile			1409 g/m L=6.01 m $I_x=34.31 \text{ cm}^4$ $I_y=6.80 \text{ cm}^4$	ET720088.00 stainless steel pin $\varnothing 5$			pcs 1

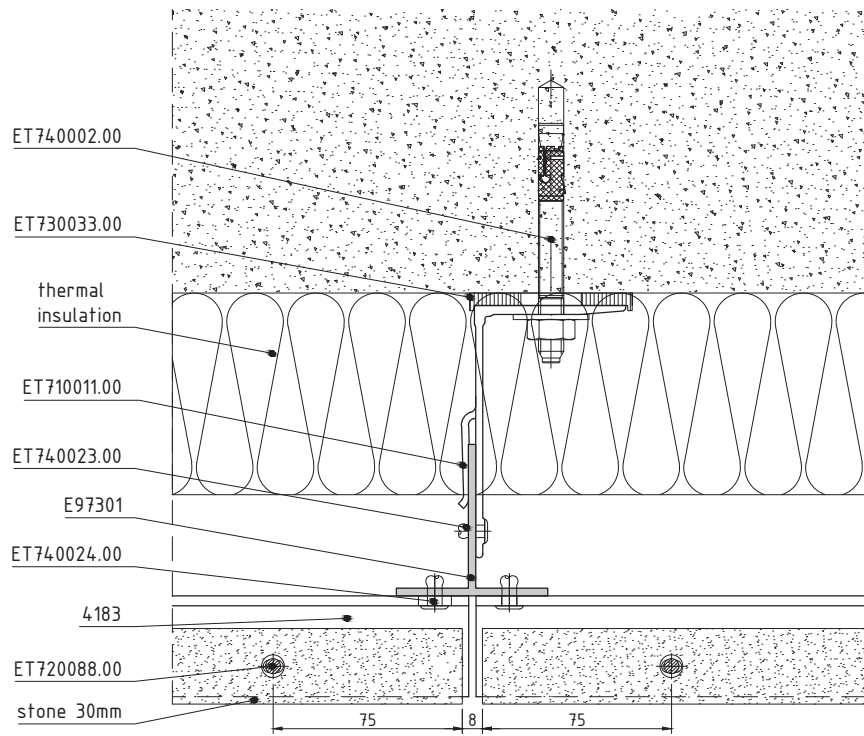
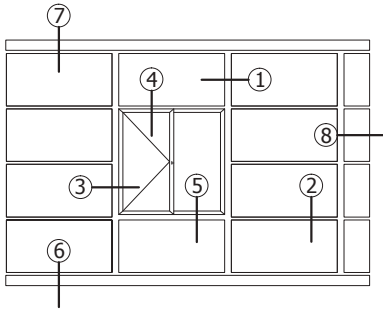

1

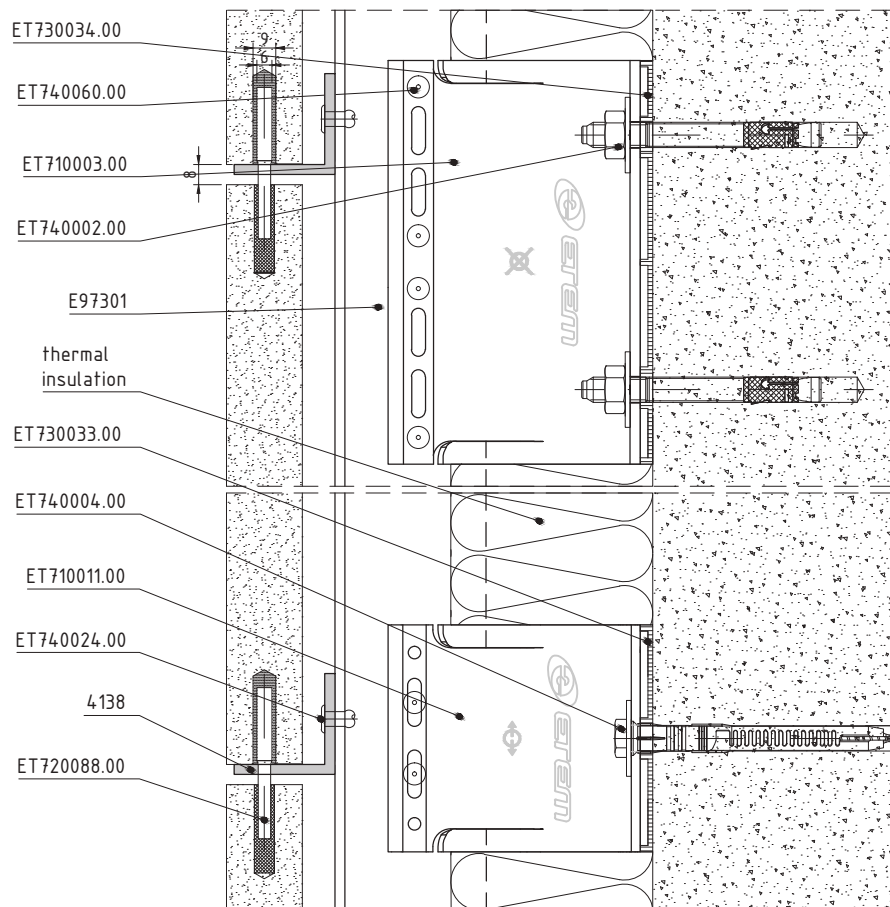

2

3

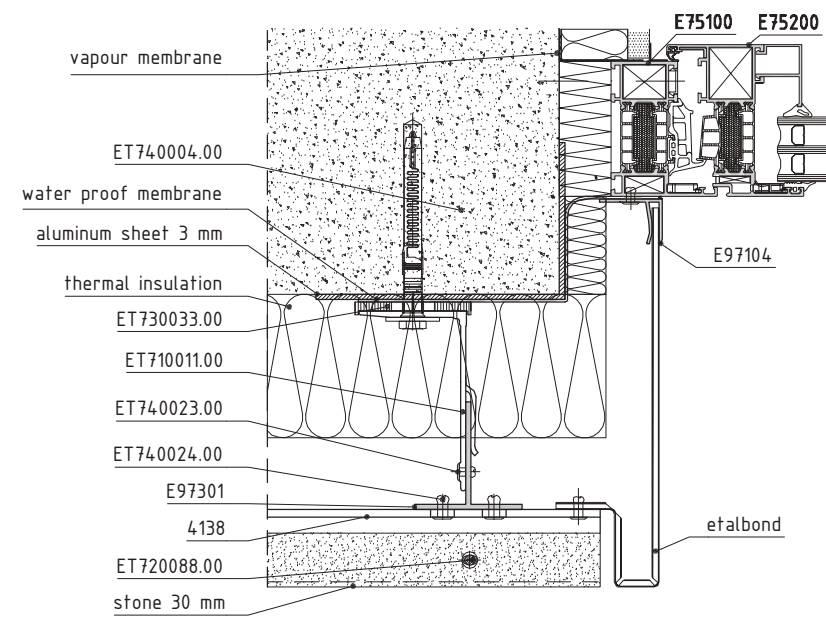

4

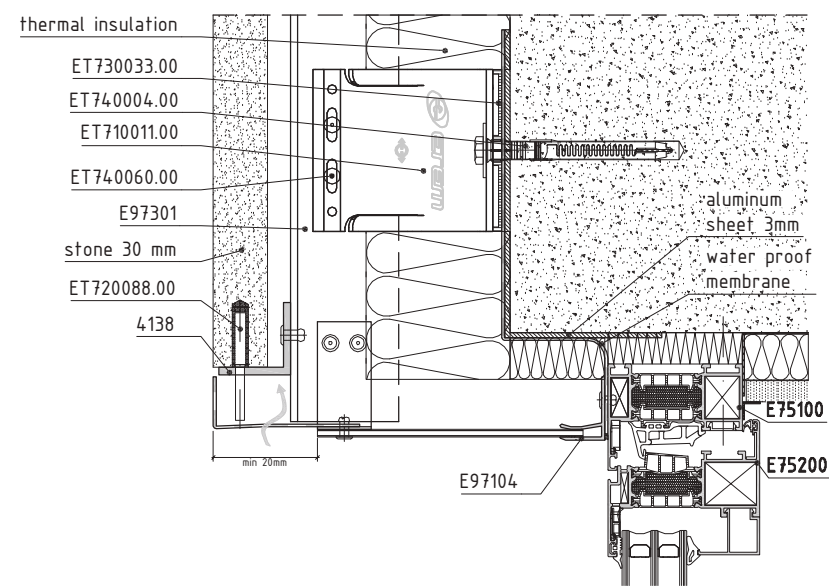

5

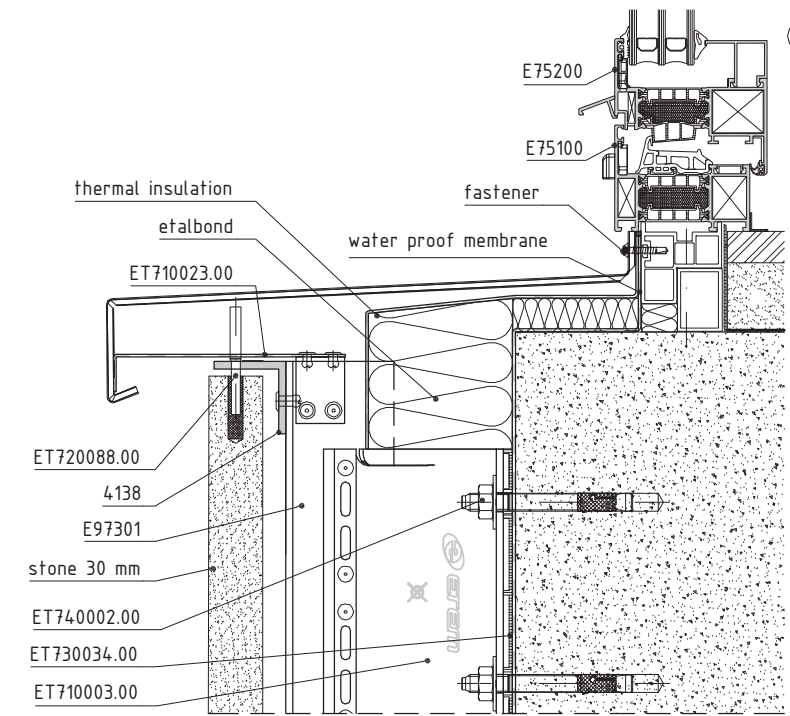

6

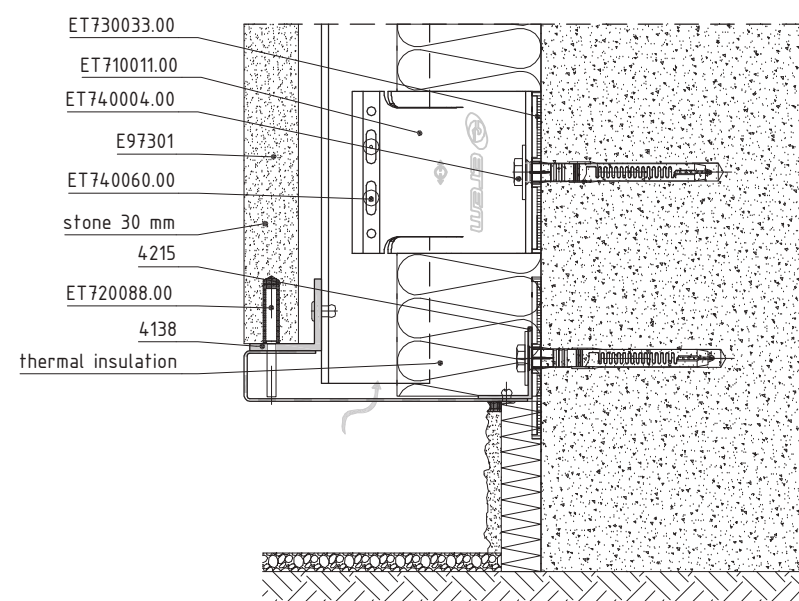

7

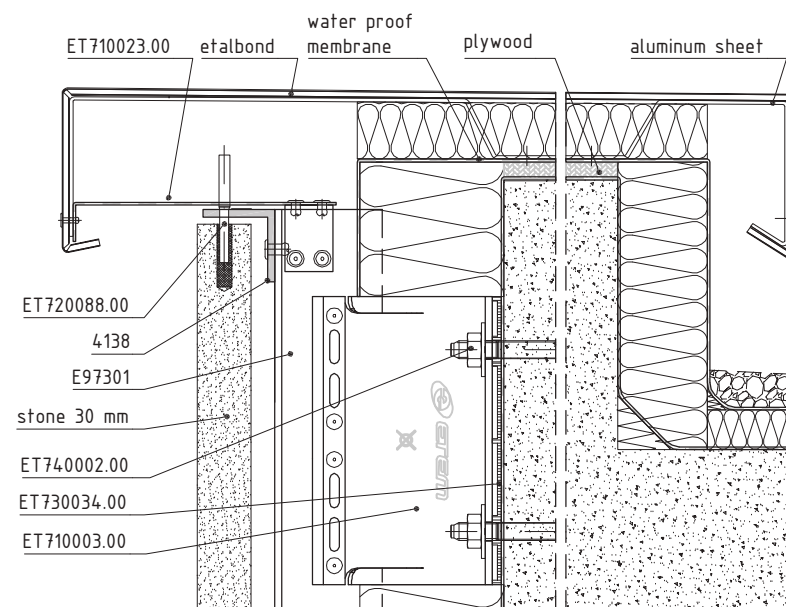

8

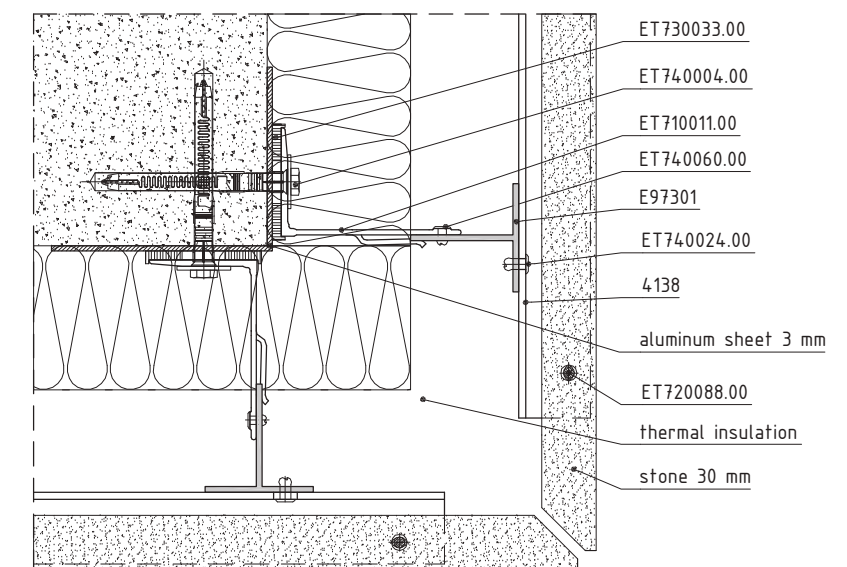

CLADDING MATERIALS

Ceramic tiles

All production procedures, starting with preparation of clays, manufacturing, glazing and firing, achieve a top-of-the-range product, that satisfies the architectural demands.

There are two kinds of ceramic tiles:

Extruded ceramics – specially designed for fixing to a metallic structure without the need for additional cutting or drilling.

- Thickness: 15–45 mm
- Height: 150–500 mm
- Length: max.1800 mm
- Weight: approx. 25–61 kg/m²

Flat ceramics

- Thickness: 3–10 mm
- Height: 600–1200 mm
- Length: max.1800 mm
- Weight: approx. 18 kg/m²

Reaction to fire class: A2, non-combustible

Appropriate ETEM VFS depend on thickness, weight and specifics of the material: FORTE, FORTE Light, VARIO Clips, VARIO GH and others.

Cement Board

A new generation building material that can be utilized to create long lasting structures, offering advantages, unobtainable to conventional construction materials. It is made of aggregated Portland cement with coated glass fibre mesh embedded in the back and front surfaces.

- Thickness: 12.5 mm
- Height: 900 mm
- Length: 1200–2500 mm
- Weight: approx. 16 kg/m²

Reaction to fire class: A1, non-combustible

Appropriate ETEM VFS: VARIO Fixings

Glass

In addition to the traditional usages of painted glass for interior applications, glass is also designed for use in cladding façades.

As exterior decorative applications, the product is designed to be heat strengthened or toughened.

- Thicknesses: 4, 6, 8 and 10 mm.
- Dimensions: 225÷321 cm.
- Weight: approx. 2.5 kg/m² per mm thickness

Appropriate ETEM VFS: FORTE Light, VARIO Clips, VARIO GH, VARIO Glue

Aluminium Composite Material

etalbond® is a composite panel, consisting of two aluminium cover sheets and a plastic core.

The composite structure of etalbond® results in an impressive strength-to-weight ratio, even when comparing large panel sizes.

- Thickness: 3, 4, 6 mm
- Standard sheet sizes: 1250/3200, 1500/3200 mm
- Weight: approx. 5.5kg/m² for 4 mm thickness

Reaction to fire class: A2, non-combustible

Appropriate ETEM VFS: BRAVO W, BRAVO U, BRAVO Y, BRAVO H

Metal sheet products

Aluminum Coated Sheets and Coils are designed for: Façades, Roofing, Suspended Ceilings, Shading systems. Solid pre-painted PVDF aluminum in Alloy 5754 provides higher anti-corrosive properties, UV protection, extremely weather resistance, dirt repellence.

The Aluminum Coated Sheets and Coils are non-combustible and completely in line with international fire protection regulations.

- Thickness: 0.7-3 mm
- Standard height: 1250, 1500 mm
- Standard length: 2-6 m
- Weight: approx. 5.4kg/m² per 2 mm thickness

Other materials: Galvanized, Prepainted Steel and AluZinc; Copper; Titanium Zinc natural and pre-weathered.

Appropriate ETEM VFS: BRAVO W, BRAVO U, BRAVO Y, BRAVO H

HPL (High Pressure Laminates)

HPL panels are duromer high-pressure laminates with additional weather protection consisting of acrylic resins. They are produced in lamination presses under great pressure and high temperature.

- Thickness: 4-15 mm
- Standard height: 1060-1850 mm
- Standard length: 2140-4100 mm

Reaction to fire class: Euroclass B-s2, d0 for 6-10 mm

Density: 1450 kg/m³

Appropriate ETEM VFS: FORTE Light, VARIO Clips, VARIO Fixings, VARIO Glue, VARIO GH

Fibre cement

Fibre cement sheets are made from natural materials: cement (i.e. a mixture of chalk and clay), sand, and water, supplemented by non-toxic organic fibres.

The surface treatment makes the material highly resistant to humidity and dirt, ensuring that regardless of what the weather throws at your façade.

Density: 1700 kg/m³

- Thickness for external façades: 6-10 mm
- Standard height: 1000-1250 mm
- Standard length: 2500-3050 mm

Reaction to fire class: A2, non-combustible

Appropriate ETEM VFS: FORTE Light, VARIO Clips, VARIO Fixings, VARIO Glue, VARIO GH

Stone and Technical Stone

Truly green building materials and most environmentally sound construction materials are natural stones like granite, marble, limestone, sandstone, travertine, slate. All stones should be considered individually for their merits in whatever use they are being considered for.

Technical Stone is a composite product, made of 95% natural material (quartz, granite, marble) and 5% polyester resin with very good physical and mechanical characteristics. Technical stone has better technical characteristics than natural stone (granite, marble, etc.) like strength, heat resistance, acid resistance, antibacterial characteristic etc.

Density: 2300 - 2800 kg/cm³

Appropriate ETEM VFS: FORTE Light, FORTE, FORTE Pins, VARIO Clips, VARIO GH

Textile membranes

Textile membranes are an excellent alternative to traditional materials. The façade system is based on the combination of a textile membrane (of different compositions) and an elastomer.

One of the main system applications is the possibility of wrapping the building with a second skin, which, apart from improving its aesthetics, permits obtaining an excellent thermal insulation level. The membrane system places no limits on creativity with

different possibilities, evaluating different changes in color, material, silkscreen printing and shapes and modulations. Combined with a LED technology lighting system, permits the creation of an unique sculpture with a changing aspect.

Fire resistance varies, according to the materials chosen for the membrane.

Customized panels are possible with this system, where the size limits are only determined by the ability to transport (up to 12x2.5 m).

Composite Mineral Material

The material is solid, non-porous, homogeneous surfacing material, composed of acrylic resin and natural minerals. Cladding is typically done with CNC routers, which create the desired shapes, and with sanding or polishing tools for different finishes. It can be fabricated to achieve different levels of light transmission by reducing the thickness of the material.

- Standard dimensions of DuPont™ Corian® sheets are:

- 4 mm sheet 930 x 2490 mm
- 6 mm sheet 760 x 2490 mm 930 x 2490 mm
- 12.3 mm sheet 760 x 3658 mm 930 x 3658 mm
- 19 mm sheet 760 x 3658 mm

Density: 1680 – 1760 kg/cm³

Reaction to fire class: Class B1

Appropriate ETEM VFS: FORTE Light, VARIO Clips, VARIO Fixings, VARIO Glue

Glass Fiber Reinforced Concrete GFRC, GFRP

The composite material formula consists of basic cement material, fine aggregate, water, dispersed resistant glass fiber and other chemical additives. It is possible to easily achieve various visual surfaces and there are no size limitations.

The panels are 8, 10, 12, 13, 15 mm thin and available in different colors.

Density: 1900–2100 kg/m³

Reaction to fire class: A1, non-combustible

Appropriate ETEM VFS: FORTE Light, VARIO Clips, VARIO Fixings, VARIO GH, VARIO Glue

Light transmitting concrete

Water, sand and cement form the concrete mixture and transmitting optical fibers are embedded in it, thus creating this material.

- The light panels are 4–10 mm thin and available in different colors.

- Standard size: 1,2m x 0,60 m

Density: about 2400 kg/m³

Reaction to fire class: A1/A2, non-combustible

Appropriate ETEM VFS: FORTE, FORTE Light, FORTE Pins, VARIO Clips, VARIO Fixings, VARIO GH

ETEM Project checklist

For each calculation of new projects by the ETEM R&D department, it is necessary for a project checklist form to be filled. It includes detailed information, which helps customers to receive a most accurate and precise offer. The offers may vary, depending on the cladding/façade material, the dimensions and weight of the material, wind load, floors heights, thickness of the thermal insulation. Also, structural base, raster of the façades, fixing methods and different ventilated facade systems. In order to achieve a qualitative calculation, it is necessary the drawings to be submitted via email/courier in CAD format. If there are any specific features of the project, these are also taken into consideration.

Incoming # _____	Date: _____	
Designers: _____		
PROJECT CHECKLIST: VENTILATED FAÇADE SYSTEMS		
1. Project name and location: _____		
2. Contractor/sales manager/architect: _____		
3. Technical contact person:		
Name: _____		
Tel.: _____ e-mail: _____		
4. Façade material:		
<input type="checkbox"/> ceramics	<input type="checkbox"/> composite material	
<input type="checkbox"/> stone	<input type="checkbox"/> aluminium sheet	
<input type="checkbox"/> HPL	<input type="checkbox"/> other	
<input type="checkbox"/> fibrocement		
Size (mm): _____	5. Additional data:	
Weight (kg/m ²): _____	Regional wind load (kN/m ²): _____	
Colour: _____	Structural base: _____	
Specific info: _____	Insulation thickness (mm): _____	
_____	Raster, joints: _____	
6. Fixing method:		
ETEM Ventilated System (<i>Bravo/Vario/Forte</i>): _____		
Visible (<i>rivets, clamps, clips</i>): _____		
Invisible (<i>adhesive, pins, undercut anchors, adaptors</i>): _____		
7. Type of offer:		
<input type="checkbox"/> technical consultation	<input type="checkbox"/> static analysis	
<input type="checkbox"/> valuable calculation	<input type="checkbox"/> specific details	
Remarks and object specifics: _____		

Sales manager /name, last name/: _____		
Date: _____		
F 7.3.02.01-2/1		

STANDARDS

STANDARDS

General

EN 12020 (1÷2) – Aluminium and aluminium alloys – Extruded precision profiles in alloys EN AW-6060 and EN AW-6063
EN 755 (1÷9) – Aluminium and aluminium alloys – Extruded rod/bar, tube and profiles
EN 573 (1÷3) – Aluminium and aluminium alloys – Chemical composition and form of wrought products
EN 15088 – Aluminium and aluminium alloys – Structural products for construction works – Technical conditions for inspection and delivery
EN 1990 Eurocode – Basis of structural design
EN 1991 Eurocode 1 – Actions on structures
EN 1998 Eurocode 8 – Design of structures for earthquake resistance
EN 1999 Eurocode 9 – Design of aluminium structures

Ventilated façade systems

ETAG 034, part 1 – Kits for external wall claddings, Part I: Ventilated cladding kits comprising cladding components and associated fixings
ETAG 034, part 2 – Kits for external wall claddings, Part II: Cladding kits comprising cladding components, associated fixings, subframe and possible insulation layer
CWCT Standard for Systemized Building Envelopes
EN 13830 – Curtain walling – Product standard
EN ISO 6946 – Building components and building elements – Thermal resistance and thermal transmittance – Calculation method
EN ISO 10211 – Thermal bridges in building construction – Heat flows and surface temperatures – Detailed calculations
EN ISO 14683 – Thermal bridges in building construction – Linear thermal transmittance – Simplified methods and default values
EN 13116 – Curtain walling – Resistance to wind load – Performance requirements
EN 12179 – Curtain walling – Resistance to wind load – Test method
EN 14019 – Curtain Walling – Impact resistance – Performance requirements
EN ISO 10140 – Acoustics – Laboratory measurement of sound insulation of building elements
EN 20140 – Acoustics – Measurement of sound insulation in buildings and of building elements
EN ISO 717-1 – Acoustics – Rating of sound insulation in buildings and of building elements – Part 1: Airborne sound insulation

LIABILITY

The stated data and calculating methods are provided by ETEM as a guideline only. The information given in this catalogue does not substitute all applicable regulations – Eurocodes, harmonized European standards, national or regional building codes.

The specific conditions and technical details of every particular project have to be taken into consideration.

The right choice of all elements as well as any special requirements regarding stability of the structure must always be considered by the structural/façade engineer, responsible for the project.

The solutions presented in these pages are indicative and can not cover all possible project cases. Because of that every single project has to be evaluated by the structural/facade engineer in charge taking into consideration the specific features, such as climate conditions, location, orientation, etc.

ETEM is not liable for any calculations and conclusions made on the basis of the stated information. All calculations and specifications must be estimated, endorsed and guaranteed by architect, engineer, professional or legal entity authorized by law for such activities.

COPYRIGHT

Copyright© II Edition 2017 ETEM

The design, structure and content of this catalogue are subject of copyright and the exclusive rights belong to ETEM. Modifying, copying, publishing, selling or licensing any part or the whole content of this catalogue are strongly prohibited without the permission of ETEM.

Any unauthorized use of content may violate copyright or other laws.

DISCLAIMER

ETEM is not responsible for any typographical errors, technical inaccuracies and following changes of the content of this catalogue.

Before starting manufacturing process, it is highly recommended to contact ETEM R&D department in order to provide you with updated information.

WWW.ETEM.COM

VFS.ETEM.COM

ETEM